

THE OFFICIAL

DOOM™

Survivor's Strategies & Secrets

Jonathan Mendoza



SYBEX

Monsters and What It Takes to Off Them

Map Code	Monster	Minimum Shots
Br	Baron of Hell	5 rockets, or 50 plasma blasts, or 1 BFG blast
Cd	Cacodemon	2 rockets, or 3-5 plasma blasts
Cyber	Cyberdemon	20 rockets, or 200 plasma blasts, or 4 BFG blasts
De	Demon	2-3 shotgun blasts
Fh	Former Human	1 bullet
Fs	Former Human Sergeant	1 bullet, or 1 shotgun blast
Im	Imp	5 bullets, or 2-3 shotgun blasts
Ls	Lost Soul	2 shotgun blasts, or use chaingun
Sp	Specter	2-3 shotgun blasts
Spider	Spider Mastermind	15 rockets, or 150 plasma blasts, or 3 BFG blasts

Special Keys in Doom

Key	Function	Key	Function
F1	"Read This"	↑, ↓	Moves you forward, backward
F2	Save Game	←, →	Turns you left, right
F3	Load Game	Alt plus ←, →	Sidestep
F4	Sound Volume	Shift plus ↑, ↓, ←, →	Speeds your movement
F5	Graphics Detail	Ctrl	Fires your weapon
F6	"Quick Save" (overwrite)	Spacebar	Opens doors
F7	End Game	Esc	Shows menu
F8	Identify Objects	Pause	Pause the action
F9	"Quick Load"	Tab	Automap on/off
F10	Quit DOOM	F11	"Gamma" Level (contrast)

For every kind of computer user, there is a SYBEX book.

All computer users learn in their own way. Some need straightforward and methodical explanations. Others are just too busy for this approach. But no matter what camp you fall into, SYBEX has a book that can help you get the most out of your computer and computer software while learning at your own pace.

Beginners generally want to start at the beginning. The **ABC's** series, with its step-by-step lessons in plain language, helps you build basic skills quickly. For a more personal approach, there's the **Murphy's Laws** and **Guided Tour** series. Or you might try our **Quick & Easy** series, the friendly, full-color guide, with **Quick & Easy References**, the companion pocket references to the **Quick & Easy** series. If you learn best by doing rather than reading, find out about the **Hands-On Live!** series, our new interactive multi-media training software. For hardware novices, there's the **Your First** series.

The **Mastering and Understanding** series will tell you everything you need to know about a subject. They're perfect for intermediate and advanced computer users, yet they don't make the mistake of leaving beginners behind. Add one of our **Instant References** and you'll have more than enough help when you have a question about your computer software. You may even want to check into our **Secrets & Solutions** series.

SYBEX even offers special titles on subjects that don't neatly fit a category—like our **Pushbutton Guides**, our books about the Internet, our books about the latest computer games, and a wide range of books for Macintosh computers and software.

SYBEX books are written by authors who are expert in their subjects. In fact, many make their living as professionals, consultants or teachers in the field of computer software. And their manuscripts are thoroughly reviewed by our technical and editorial staff for accuracy and ease-of-use.

So when you want answers about computers or any popular software package, just help yourself to SYBEX.



For a complete catalog of our publications, please write:

SYBEX Inc.
2021 Challenger Drive
Alameda, CA 94501
Tel: (510) 523-8233/(800) 227-2346 Telex: 336311
Fax: (510) 523-2373



SYBEX is committed to using natural resources wisely to preserve and improve our environment. As a leader in the computer book publishing industry, we are aware that over 40% of America's solid waste is paper. This is why we have been printing the text of books like this one on recycled paper since 1982.

This year our use of recycled paper will result in the saving of more than 15,300 trees. We will lower air pollution effluents by 54,000 pounds, save 6,300,000 gallons of water, and reduce landfill by 2,700 cubic yards.

In choosing a SYBEX book you are not only making a choice for the best in skills and information, you are also choosing to enhance the quality of life for all of us.

This Book Is Only the Beginning.

Get Source Code, Shareware, and More on the SYBEX Forum on CompuServe®.

Now you can download the source code for the material covered in this book. From the privacy of your own home or office, you can have access to a wide variety of source code, utilities and shareware. Plus you'll be able to talk to SYBEX authors and editors, and other forum members who share your interests.

Expert Advice at No Extra Charge.

As a SYBEX Forum member, you'll have access to expert tips and hints about your computer and the most popular software programs. Just access CompuServe and enter GO SYBEX.

What's more, you can download the source code from programs covered in SYBEX books, discover professional quality shareware, suggest topics for future books, share information with other SYBEX Forum users and more—for no additional charge. All you pay for is your CompuServe membership and connect time charges.

Get a Free Serving of CompuServe.

If you're not already a CompuServe member, try it for free. Call, toll-free, 800-848-8199 and ask for representative #560. You'll get a personal ID number and password, one **FREE** month of basic service, a **FREE** subscription to *CompuServe Magazine*, and a \$15 credit towards your CompuServe connect time charges. Once you're on CompuServe, simply enter GO SYBEX and start to explore the SYBEX Forum.

Tune In Today.

The SYBEX Forum can help make your computer an even more valuable tool. So turn on your computer and visit the SYBEX Forum on CompuServe. You'll be glad you did.

SYBEX. Help Yourself.



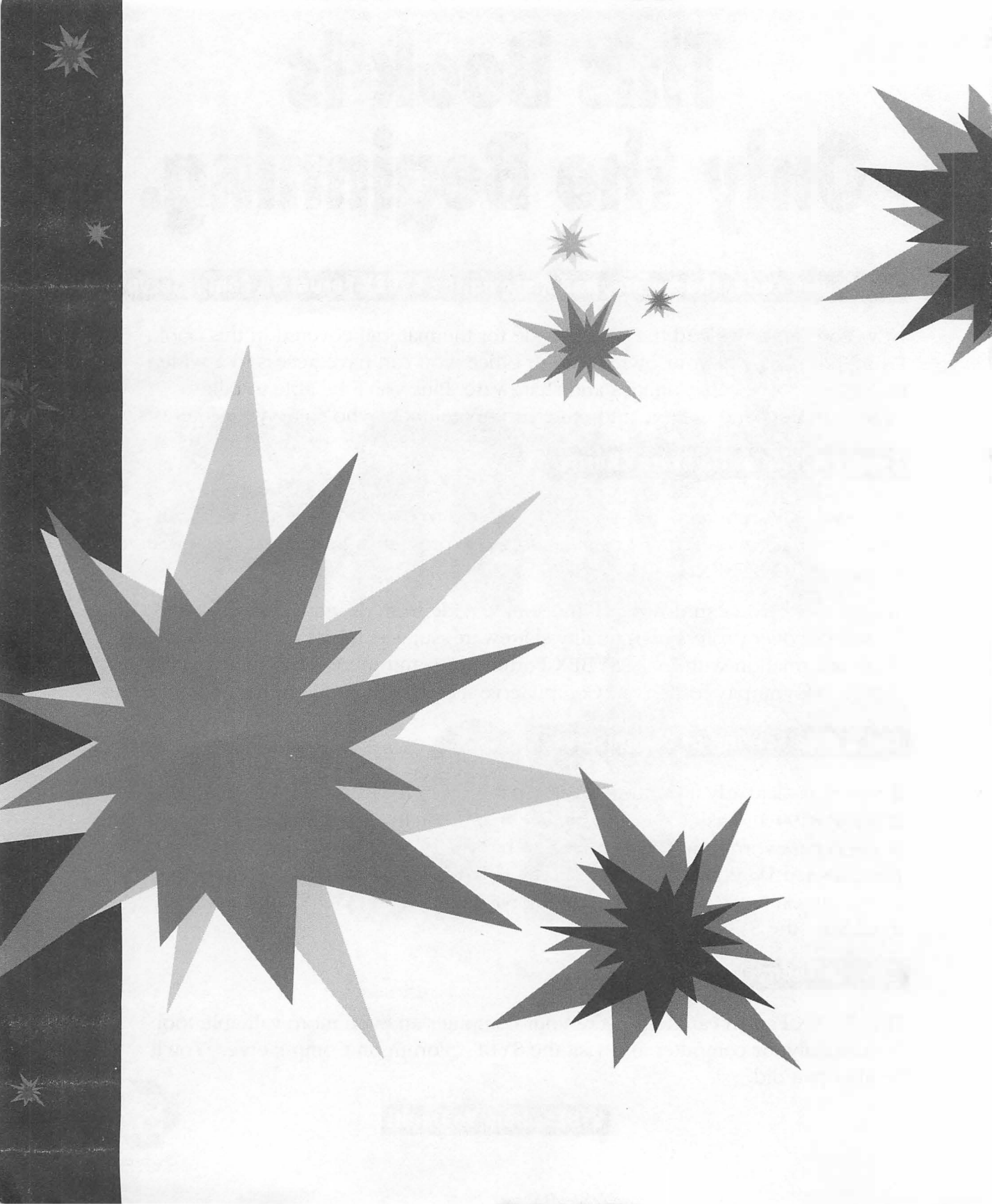



**THE OFFICIAL
DOOM™
SURVIVOR'S
STRATEGIES
& SECRETS**



JONATHAN MENDOZA



SYBEX

SAN FRANCISCO

PARIS

DÜSSELDORF

SOEST



Developmental Editor: Gary Masters

Editor: D. Robert

Technical Editor: Aaron Kushner

Book Designer: Ingrid Owen

Chapter Art: Helen Bruno

Screen Graphics: John Corrigan

Page Layout/Desktop Specialist: Stephanie Hollier

Proofreader/Production Assistant: Sarah Lemas

Indexer: Ted Laux

Cover Designer: Archer Design

DOOM is a registered trademark of id Software, Inc.

SYBEX is a registered trademark of SYBEX Inc.

TRADEMARKS: SYBEX has attempted throughout this book to distinguish proprietary trademarks from descriptive terms by following the capitalization style used by the manufacturer.

Every effort has been made to supply complete and accurate information. However, SYBEX assumes no responsibility for its use, nor for any infringement of the intellectual property rights of third parties which would result from such use.

Copyright ©1994 SYBEX Inc., 2021 Challenger Drive, Alameda, CA 94501. World rights reserved. No part of this publication may be stored in a retrieval system, transmitted, or reproduced in any way, including but not limited to photocopy, photograph, magnetic or other record, without the prior agreement and written permission of the publisher.

Library of Congress Card Number: 94-66139

ISBN: 0-7821-1546-2

Manufactured in the United States of America

10 9 8 7 6 5 4 3 2



To Diana

For her love and support in times of impending doom

ACKNOWLEDGMENTS

When I started writing this book, I wanted it to be entertaining, irreverent, and informative. Doom is a dazzling game of violence and intelligence and it deserves no less. I only hope I have done it justice. I wish to thank id Software's John Romero, Sandy Petersen, Kevin Cloud, John Carmack, Jay Wilbur and all the others for their contributions and their help in making this book possible. Another person worthy of recognition is the very capable Doug Robert, my SYBEX editor, who kept an eye on my prose and another on schedules and production considerations. Let me also thank Hank Leukart for the use of his priceless labor of love, *The "Official" Doom FAQ* (Frequently Asked Questions), a most valuable resource and reference. Finally, I want to say thanks to Gary Masters, trusted friend, mentor, and advisor, for an unexpected and very timely plate of shrimp.

—Jonathan Mendoza (Internet: mao@tenet.edu;
CompuServe: 73771,1637)

CONTENTS AT A GLANCE

INTRODUCTION	xvii
PART ONE: BASIC TRAINING	
ONE Blow 'em Away First, Ask Questions Later	3
TWO More Doom Basics (In Phobos No One Can Hear You Scream)	15
PART TWO: KICKING INTERDIMENSIONAL BUTT	
THREE Understanding the Doom Episodes and Level Maps	49
FOUR Knee-Deep in the Dead	59
FIVE The Shores of Hell	119
SIX Inferno	173
PART THREE: INTELLIGENCE BRIEFING	
SEVEN Doom in MultiPlayer Mode	233
EIGHT For the Technically Inclined	241
NINE Interviews with the Doom Creators	247
APPENDIXES	
A Installing and Troubleshooting Doom	261
B Cheaters Always Finish First	273
C Doom Add-Ons and Resources	279
INDEX	289

TABLE OF CONTENTS

INTRODUCTION

xvii

PART ONE: BASIC TRAINING

ONE	Blow 'em Away First, Ask Questions Later	3
	Who Am I and What the Hell Am I Doing Here?	4
	Your Mission—It's Not Like You Have a Choice	5
	Getting Your Feet Wet or Your Butt Kicked— Whichever Comes First	6
	Controlling the Action	6
	A Short Tour	9
TWO	More Doom Basics (In Phobos No One Can Hear You Scream)	15
	How to Use the Doom Menu	16
	New Game	18
	Using the Options Menu	19
	Save Game (F2)	20
	Load Game (F3)	21
	Read This	21
	Quit Game (F10)	22
	How Tough Is My Opposition?	22
	Your Arsenal	27
	The Weapons	28
	The Ammo	30
	Electronic Gadgets	32
	Bodily Aids and Supernatural Artifacts	33
	The Medical Aids	34
	The Protective Items	34
	Supernatural Artifacts	36

The Status Bar and What It Tells You	37
The Art of War in Doom: Skills and General Strategy	39
Mastering Your Movement	39
Fighting	40
Exploring Your Surroundings and Uncovering Its Secrets	41
Tips for MultiPlayer Mode	42

PART TWO: KICKING INTERDIMENSIONAL BUTT

THREE	Understanding the Doom Episodes and Level Maps	49
	The Installation Maps	51
	The Blueprint and Ideal Route Map	51
	Monster Alert, Weapon, and Artifact Locator Map	51
	Interpreting the Blueprint Map	51
	Interpreting the Monsters, Weapons, and Artifacts Map	53
	What's in a Doom Episode?	55
	Your Performance	56
FOUR	Knee-Deep in the Dead	59
	The Hangar	60
	The Nuclear Plant	65
	The Toxin Refinery	71
	Command Control	79
	Phobos Lab	85
	Central Processing	90

Computer Station	98
Phobos Anomaly	106
Military Base: The Secret Level	112
FIVE The Shores of Hell	119
General Tips	120
Deimos Anomaly	121
Containment Area	126
Refinery	133
Deimos Lab	137
Command Center	145
Halls of the Damned	153
Spawning Vats	160
Tower of Babel	166
Fortress of Mystery	170
SIX Inferno	173
Hell Keep	174
Slough of Despair	179
Pandemonium	185
House of Pain	190
Unholy Cathedral	198
Mount Erebus	205
Limbo	213
Dis	221
Warrens	224

PART THREE: INTELLIGENCE BRIEFING

SEVEN	Doom in MultiPlayer Mode	233
	Friend or Foe: Deathmatch vs. Cooperative Play	234
	Initial Entry Location	235
	Weapons and Keys	235
	The Status Bar	235
	The Automap	235
	Spy Mode	235
	Game Tallies	236
	Basic Game Operations	236
	New Controls	236
	New Options	237
	MultiPlayer Platforms	237
	Launching MultiPlayer Mode	238
	The Setup Menu	238
	SERSETUP	239
	IPXSETUP	240
EIGHT	For the Technically Inclined	241
	Goals	242
	Implementation	243
	Afterthoughts	245
NINE	Interviews with the Doom Creators	247
	A Brief Conversation with John Romero and Sandy Petersen, Doom Level Designers and Writers	248
	Sandy Petersen Unleashes the Lizard Brain: How I Created Doom	253
	Kevin Cloud on the Art Process of Doom	257
	Happy Doomming	258

APPENDIXES

A	Installing and Troubleshooting Doom	261
B	Cheaters Always Finish First	273
C	Doom Add-Ons and Resources	279
	INDEX	289

INTRODUCTION

Dark and futuristic, deadly and mythical, magical and dangerous. These words beg to be spoken when the subject is Doom, a virtual-reality action game the likes of which no one could possibly have dreamt—not in their worst nightmares or most inspired flights of imagination. Doom is a frothy concoction of horror, science fiction, and heart-pounding action mixed in an interdimensional warp-speed blender. Bottoms up.

FIRST THINGS FIRST: MINIMUM REQUIREMENTS

To run Doom, you need a PC or PC-compatible 386DX or better with at least 4 megabytes of RAM, a VGA graphics card, and a hard-disk drive.

NOTE

The first episode of Doom is available as shareware from id Software. The more advanced episodes must be purchased by registering your shareware version. This book covers all the currently available episodes.

The makers of Doom recommend a 486 or better, a mouse or joystick, and a Sound Blaster Pro sound card (or fully compatible). If you intend to play Doom over a network, it must use the IPX protocol.

Besides all that, to succeed in Doom, or at least be semi-competitive, you must possess above-average intestinal fortitude, a

keen mind, vast resourcefulness, and, above all, an unrelenting desire to survive.

WHAT IS DOOM?

In a capsule, Doom is about a rugged and somewhat jaded Marine who is caught in an improbable web involving a conglomerate giant, the military, toxic waste disposal, interdimensional gateways, and some rather ghastly creatures emerging from said gateways. Our antihero's saga begins on Mars, where he has been reassigned because of an earlier, shall we say, "attitude" problem. Although the officer who wound up encased in a full-body plaster cast would probably label the Marine's actions as a bit more drastic than simple misaligned attitude.

Collaborating with the military, the Union Aerospace Corporation (UAC) has set up research facilities on Phobos and Deimos, the red planet's twin moon system. UAC's research centers around some strange structures found in each of the moons. These never-before encountered structures were given the name *Anomalies*. Early research shows the Anomalies are ruptures in the fabric of time/space which actually provide access to "interdimensional gateways." Using these gateways, UAC has been able to experiment with interdimensional space travel, sending objects and organic matter from one moon to the other. But as destiny would have it, this meddling with forces and laws beyond our comprehension has had some unexpected, baffling, and ultimately, horrifying results. The gateways have recently become unstable and, basically, all of Hell's dark children have come to visit you today.

When the Marines arrive on Phobos, after heeding the desperate cry for help from the lunar scientific base, they encounter a scenario that defies all logic, that reaches deep into the darkest corridors of your deepest fears: a face-to-face encounter with evil incarnate in a labyrinthine nightmare. If Poe, Dante, and Lovecraft were alive to see Doom today, they might well feel vindicated.

The Doom experience soars to a higher plateau when played over a network with up to four of your friends (or foes). In *MultiPlayer mode* you can team up and play cooperatively. But if you crave some serious violence, engage anyone who dares into *Deathmatch*, where everyone is out for himself. If you're not linked to a network, you can still team up or battle another human via a trusty modem.

WHY THIS BOOK?

Chances are you purchased this book because you are already a Doom aficionado and are hungry for more knowledge about the game you love. A game that speaks to your tenacious nature, your competitive spirit, and your confidence in logic. Be reassured, you've made a wise purchase. This book is filled with little-known facts, insider information, winning strategies, maps of the different levels, and a wealth of other stuff that will greatly enhance your enjoyment of the game and your appreciation for the Doom universe.

If your exposure to Doom has been limited to looking over someone's shoulder or playing the shareware version of the program, do not fear. *The Official Doom Survivor's Guide* was written in a "first things first" format, with tyros like you in mind in the earliest chapters. Together we'll explore Doom's corridors, passageways, and secret doors, as we become familiar with floor plans that M. C. Escher would give the thumbs-up to. (In fact, one of the most enthralling aspects of Doom, precisely, is solving the many puzzles of its amazing architecture.) And we'll introduce the denizens of the otherworld early on so you can dispense with pleasantries when you actually encounter them in the hallways.

Anyone from the hard-core game aficionado to the casual computer user can discover in this text a rich reference source for taking the interdimensional leap into the world of Doom with some measure of knowledge, skill, and newly found delight.

WHAT THIS BOOK COVERS

This book covers every aspect of Doom from the most elemental single-player action to a Deathmatch scenario involving up to four players in a network. The appendixes present more esoteric and technical aspects of the game, including such topics as installing the game, troubleshooting, cheating, and playing and communicating with others over networks (including such large nets as CompuServe and the Internet). In short, this book gives you the key to conquer Doom and outdo yourself.

The book is divided into three main sections:

- Part One: Basic Training
- Part Two: Kicking Interdimensional Butt
- Part Three: Intelligence Briefing

Part One: Basic Training

The three chapters in this part introduce you to the world of Doom. In *Chapter 1* you learn who you are and why you're on a Martian moon. You also find out what your ultimate objective is. To get your feet wet and give you a sense of your surroundings, Chapter 1 also takes you on a brief tour of the very first level. After browsing this brief chapter, we suggest you play around a bit with the game to get a feel for how it works. Then come back to *Chapter 2* for the more substantive portion of Part One. It covers everything from using the Doom menus to full profiles of your adversaries and descriptions of your arsenal and useful artifacts, and examines the art of war in Doom. Even if you are an experienced Doom player, you might want to read this to freshen up on your fighting and exploration techniques. There is also a section that gives you pointers for MultiPlayer mode.

Part Two: Kicking Interdimensional Butt

Think of this part as the meat and potatoes of the book. This is the reference section you can turn to anytime you have a question about the level you are playing or are about to play. Comprising four chapters, this section deals first with general concepts about the Doom installations and then proceeds to cover in detail each of the three Doom episodes. *Chapter 3* tells you how to read the blueprint maps. *Chapters 4, 5, and 6*, respectively, dissect each of the Doom episodes in full and systematic detail.

Part Three: Intelligence Briefing

This part contains a potpourri of material ranging from MultiPlayer mode setup (*Chapter 7*) to meandering conversations with the folks at id Software who conceived and set out to write an action/adventure 3-D program that breaks new ground in every area (*Chapter 9*). In between, *Chapter 8* includes never-before-released technical information about Doom's advanced 3-D engine, its implementation, and the development environment.

The Appendixes

Finally, the appendixes disclose other incidental, but very valuable information. For instance, Appendix A covers installing Doom and troubleshooting common problems. Appendix B reveals all the cheat codes you could ever want (walking through walls, reaching the “God” mode, getting all weapons and ammo, etc.). Appendix C recognizes the burgeoning bulletin board networks and the various information service forums that girdle the globe, where Doom is the cause célèbre for aficionados and thrill-seekers alike. In the last appendix we give you the low-down on how you too can connect with Doom enthusiasts who share your interest, enthusiasm, and courage.

In brief, this book is the official guide and reference to Doom. It is the only publication endorsed by id Software, the company responsible for Doom’s inception. In this sense, this book is a labor of love from the people who dreamed the game for the people who live the game. But enough idle chat. Inferno awaits us all.

A WORD OR TWO ABOUT VIOLENCE

Doom is a violent game. Let’s get that out of the way. Doom is not meant for everybody. Especially not for people who take a game that was designed purely as a form of entertainment as anything more than that. Over the last few years, social critics, politicians, religious leaders, and other self-proclaimed moral barometers have been advancing the concept that America’s moral fiber is rapidly decaying, and that our media and entertainment vehicles are largely to blame. Mass media, they tell us, portrays violence and aberrant behavior as something that is glamorous or desirable.

The creators of Doom like violence. “We like shooting pixels,” states Kevin Cloud, Doom artist and writer. “Others like shooting live squirrels.” Kevin remembers the adverse reactions some people had to id Software’s last mega hit, Wolfenstein 3D. “In Wolfenstein 3D, you engage vicious Nazis in mortal combat. At one point in the game, German Shepherd dogs go for your throat. So you also have to shoot

them. It was amazing to me that a number of people sent us hate mail condemning us for shooting dogs. In other words, it was okay to kill people but not dogs. I'm sensitive to people's feelings for their pets. But I think much of this reaction is nothing more than cultural brainwashing. People are starting to believe the media is evil because other people tell them it is."

Another point of contention a few people have with Doom is the use of demon-like creatures and satanic symbology in the graphics. One person who previewed Doom wrote id Software and stated: "Upon playing Doom I was blown away by the best graphics I've ever seen. [Unfortunately,] as the technology got better, so did the satanic symbols.... This very real supernatural world should not be toyed with."

We respect this person's opinion. There is no reason why she, or anyone, should play a game that they find disturbing. To them we say, Doom is not for you. And neither are the *Evil Dead* movies, *The Exorcist*, *The Omen*, *Dracula*, and, in some extreme cases, not even Halloween or Caspar the Friendly Ghost. But let's face it. There is nothing new about Satan. He's been around since before biblical times. Why, you can't go to church without hearing about the Prince of Darkness. So it's not like Doom is injecting something unheard of in our society into the realm of computer games. In fact what makes much of our entertainment industry successful—be it movies, computer games, Broadway productions—is the constant battle between good and evil. As Sandy Petersen (id Software writer/designer) puts it, "It's not like the demons in Doom are praiseworthy." Well put, Sandy.

Besides, the entire premise of Doom is that by episode 3, Inferno, you are transported to the surface of Hell itself, where you must continue duking it out with the bad guys, not join their ranks and worship the fallen one.

The debate on the portrayal of violence will go on for decades. What is important to remember in all of this is that we all have choices. id Software is in the business of entertainment and designing state-of-the-art games; it by no means wishes to promote violence in the real world. id Software believes that you alone should make the choice as to what really is violent and what is just a cool game.

PART ONE

**BASIC
TRAINING**

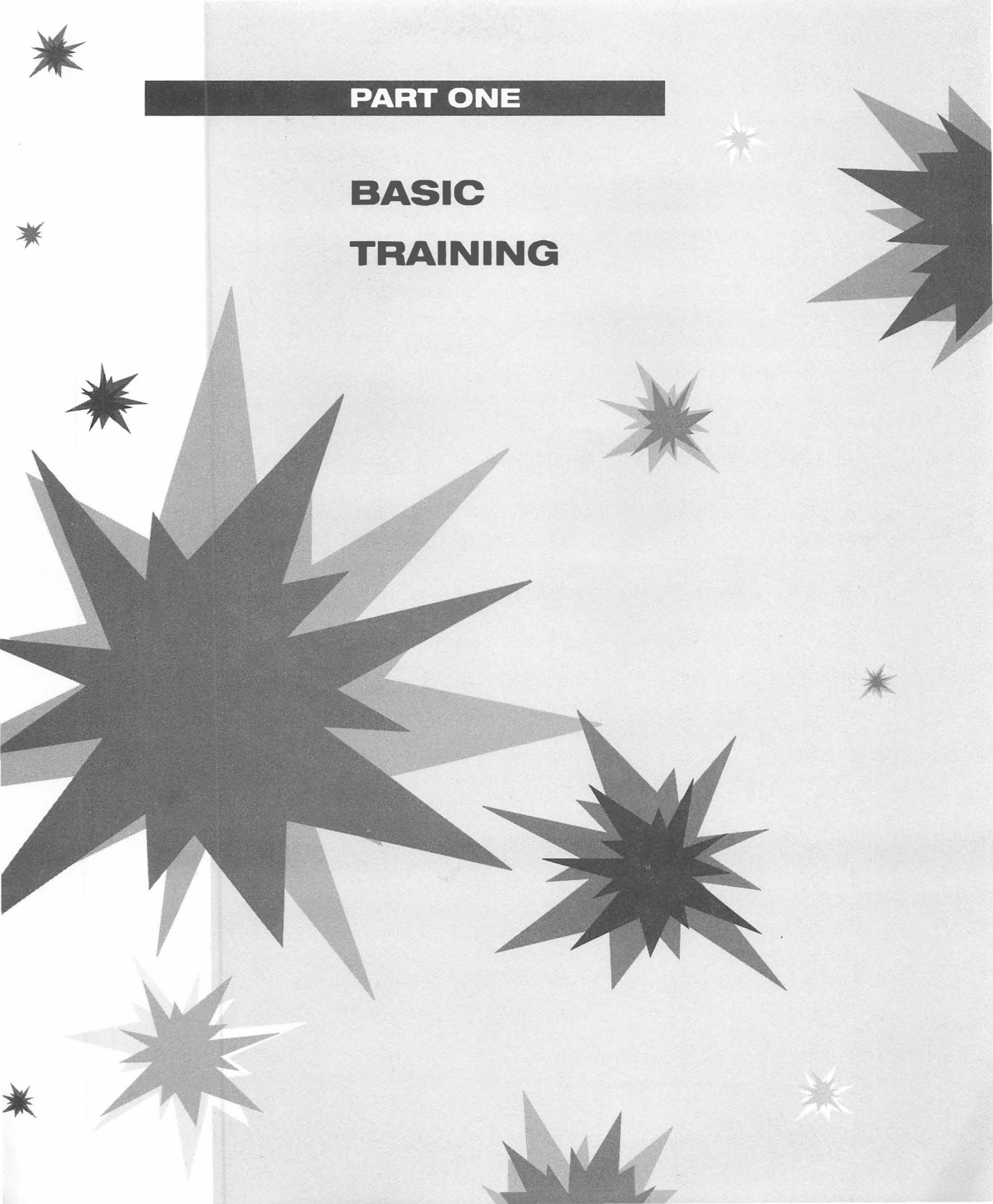

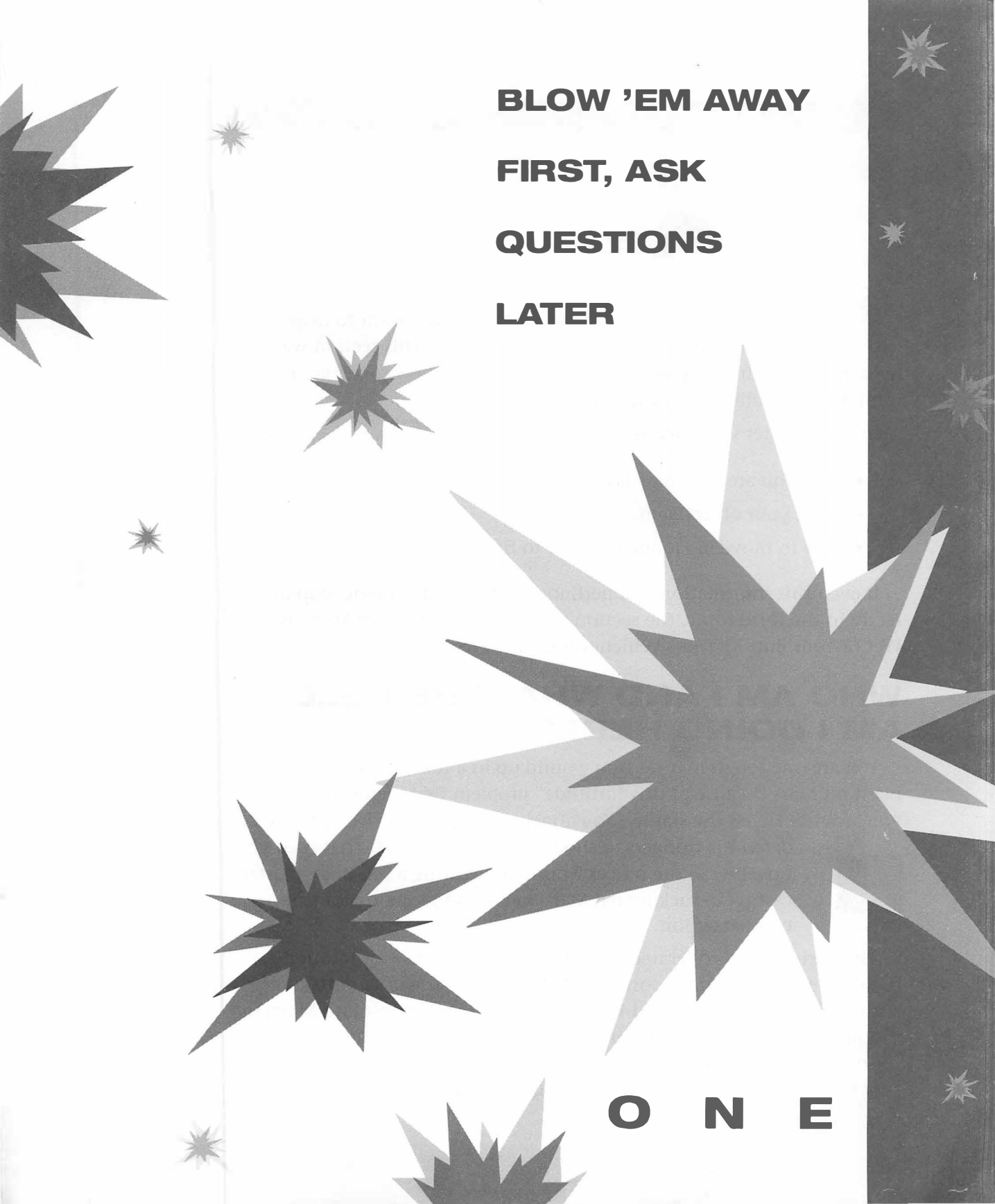

**BLOW 'EM AWAY
FIRST, ASK
QUESTIONS
LATER**

O N E

If you are new to the world of Doom, you probably want to dispense with the formalities and get right down to business. This section was written for you. It tells you just what you need to know to get your feet wet (and hopefully not in a radioactive puddle).

In this chapter you'll learn:

- Why you are on a Martian moon.
- What your objective is.
- How to move in Doom and how to fire your weapons.

If even this information is superfluous to you at this point, skip directly to the third topic, the section we've entitled "Getting Your Feet Wet or Your Butt Kicked—Whichever Comes First," later in the chapter.

WHO AM I AND WHAT THE HELL AM I DOING HERE?

You are one tough marine. You wound up in a toxic waste disposal plant on Mars because of this "attitude" problem that seems to follow you around. Here's the skinny. You attacked a superior officer after he ordered his troopers to shoot unarmed civilians. That riled you up a bit. So the officer wound up wearing a full-body plaster cast; you, sucking red Martian dust and longing for some real combat action.



The toxic plant is operated by the Union Aerospace Corporation (UAC), a multiplanetary conglomerate. UAC also has scientific research bases on Phobos and Deimos, the otherwise desolate Martian moons, where bizarre structures named "Space Anomalies" were found. These anomalies are quite extraordinaire. UAC and the military have been using them to investigate interdimensional space

travel. That is, teleporting objects and organic matter across “gateways” between Phobos and Deimos.

But lately it seems that the gateways have become somewhat unstable. The human “volunteers” who’ve taken the interdimensional leap have undergone unexplainable physiological changes. Some subjects were lost to the gateways. Others not so fortunate have literally exploded without warning just a few hours after emerging.

But things can always get worse. Just minutes ago, the incoming message from Phobos left no doubt there was something awfully wrong. According to the desperate request for military support, something evil was materializing in the gateways.

So now you find yourself guarding the perimeter of the Phobos moon base, alone and armed only with a handgun. The rest of the platoon went in taking all the heavy weaponry, leaving you behind as their best last-chance fighter. After a few agonizing hours of waiting to be called in, the silence you’re hearing on your radio is enough to fray your nerve fibers raw. Knowing any chance of ever leaving Phobos lies inside, you don your helmet, tightening your grip on the handgun, and head straight for the entrance latch. Without another thought, you know it is time to stare Doom in the eye.



YOUR MISSION—IT'S NOT LIKE YOU HAVE A CHOICE

Your objective is simply stated: Go inside each of the Phobos plant installations in systematic search of ammo and answers, and along the way, kick some serious interdimensional rear. And pray that you can avoid an untimely death. To better your odds, use any weapons and ammunition you pick up along the way. You'll need them. You'll be slug-ging it out with whatever evil forces came through the gateways. There

are also other electronic gadgets and supernatural aids that might prove useful, if not right-out lifesaving.

Ultimately, you want to make it back to Earth and out of the hellish nightmare you're in. But how? Can it be done? The answers may be as close as your fingertips or as far as Earth from Mars. Perhaps the gateways hold the clue....

GETTING YOUR FEET WET OR YOUR BUTT KICKED—WHICHEVER COMES FIRST

This is where we lead you by the hand. Come along and take your first few steps in the world of Doom. Learn how to move around, shoot, and pick up some valuable tips and general strategy.

Start the game by accessing DOS. Once in DOS, change to the directory where you installed Doom. (Most often, this is the DOOM directory.) At the DOS prompt for the Doom directory, simply type **DOOM** and press ↵. (If you haven't installed Doom, see your user guide. Or simply refer to Appendix A in this book.) An auto-demo starts running. Sit back for a few minutes, let the demo run, and get a feel for the Doom experience.

CONTROLLING THE ACTION

Before we take you on a short tour of the Hangar (the first building), you should know a little something about the various ways you can control your movement and the action in Doom. Basically, there are four ways to do it. You can use:

- The keyboard alone
- The keyboard and the mouse
- A joystick alone
- A joystick and the keyboard

You can also use pad devices (like the Gravis Gamepad) and trackballs. Because these devices are a bit more uncommon with PCs, we talk about them in Appendix A, "Installing and Troubleshooting Doom."

The Keyboard Alone

Many people like sticking only with the keyboard because they are so used to typing. Controlling the action with the keyboard only is fine. The only keys involved are:

↑	Moves you forward.
↓	Moves you backward.
←	Turns you left.
→	Turns you Right.
Ctrl	Fires your weapon.
Alt plus ← or →	Lets you sidestep. To strafe, hold down the Ctrl key at the same time.
Shift plus any cursor key	Speeds your turning, strafing, or running.
Spacebar	Opens doors. (Some doors might require you to possess a key of a certain color before they will open.)

NOTE

The main disadvantage of using only the keyboard is that you may lack the precision that you can achieve with the mouse or a trackball.

You can also use the comma and period keys to sidestep left and right respectively. (Why these two keys? Because on most PC keyboards, the comma and period keys also show the symbols < and >, kind of like an extra pair of arrow keys.)

The Mouse and the Keyboard

This is the combination most preferred by power players. You can get consistent speed and direction control from the keys, but you can take advantage of the bursting speed of the mouse for really fast turns. To use just the mouse, just hold down the left or right mouse button (depending on

how you've got your mouse set up) and move the mouse in the direction you want to go; and click or press the other button to fire. By the way, a three-button mouse is highly recommended. Doom's Setup menu (see Appendix A) lets you assign functions to each button.

Here are the default settings for a three-button mouse:

Primary Button	Fire weapon.
Middle Button	Sidestep.
Third Button	Go forward. (Double-click to open a door.)

By using the mouse in combination with the keyboard, you can have more control. An example is shown below. The main disadvantage of using a mouse with the keyboard is that it may not feel natural to some people, so it takes some practice to achieve good control. Also, because the mouse lets you turn very fast, you may easily turn too far. But when you finally have mastered it, the keyboard/mouse combination is really hard to beat. If you normally use the mouse with your left hand you may have an easier time mastering the keyboard/mouse combination, because it is easier to manipulate the cursor keys using the right hand.

Making a Fast 180-Degree Turn Here's how to make a really fast 180-degree turn so you can see what's behind you. This technique uses the keyboard/mouse combination:

Place your hand over the mouse as you normally do. With your other hand over the keyboard, position your fingers so you can press the ← or → cursor keys and Shift at the same time. (Naturally, you want to press the cursor key that corresponds to the direction you want to turn.) Along with that, trace a quick right- or left-pointing curve with a sweeping motion of the mouse. For a right 180 turn, start with the mouse at 12 o'clock and trace a clockwise semicircle finishing at 6. Conversely, for a left 180 turn, start at 12 o'clock and trace a counter-clockwise semicircle finishing at 6.

Be ready to release the keys and cease mouse movement as soon as you complete your turn.

A SHORT TOUR

For our little guided tour, we will use the keyboard as a means of control. If you are using a joystick or the mouse in addition, make the necessary adjustments. (See “Controlling the Action” earlier in this chapter.) When you are ready to stop the Doom demo, press any key. The Doom main menu (Figure 1.1) appears next.

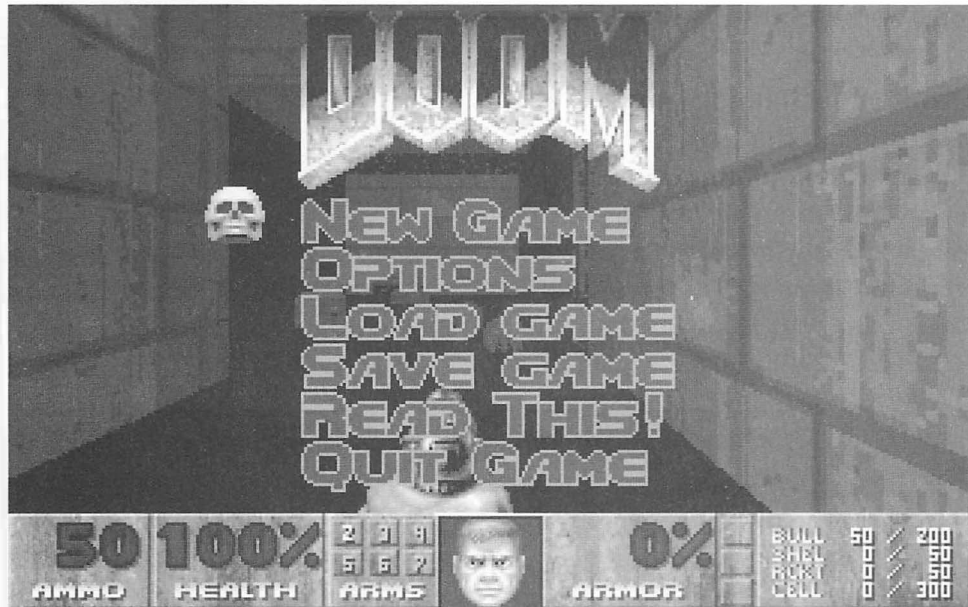

FIGURE 1.1 *The initial menu screen*

The skull that’s hanging out to the left of the options is your selection cursor here. Move the skull cursor to **New Game** using your mouse, keyboard, or joystick, and press ↵.

Now you get to choose among the three Doom episodes. Move the cursor to **Knee-Deep In the Dead** and press ↵. The screen changes to list the levels of difficulty. (If you only have the shareware version of Doom, you can only access the first episode, Knee-Deep in the Dead.)

For now, choose **Hey, Not Too Rough**. You will find yourself inside the Hangar installation, viewing everything from the marine's perspective—that is, your perspective (Figure 1.2). Notice you are in a large room with a sunken blue floor in the middle. If your view seems unusually dark, press F11 to cycle through the four different lighting levels (these are known as “gamma” selections) and press the Esc key to choose one.

Look at the Status Bar across the bottom of the screen. This informs you of how your health and ammo are holding up. We discuss the Status Bar at length in Chapter 2.

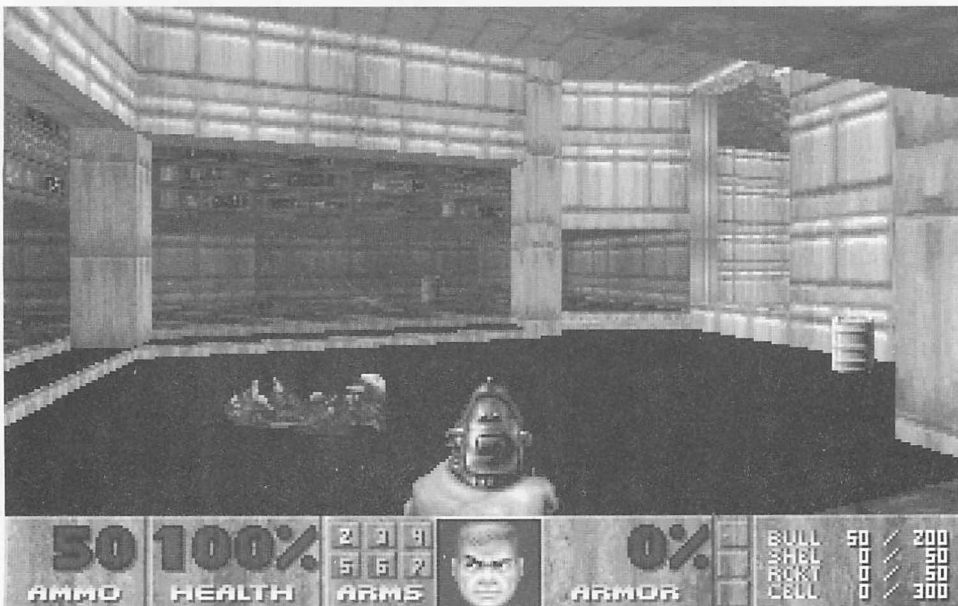
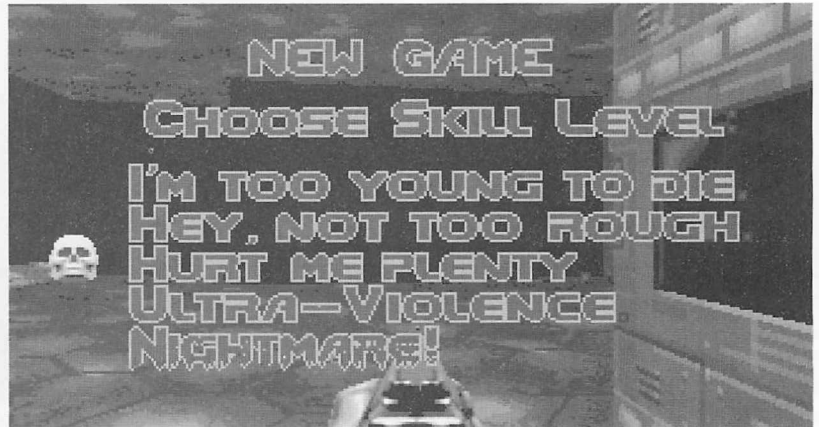

FIGURE 1.2 *Your perspective*

Walk directly ahead by pressing ↑. See how your hand weaves slightly with each step, simulating real walking. Turn right by pressing → and walk toward the two large windows overlooking a vast courtyard. Can you see the green toxic slime pool? Sitting in it dead-center is a blue vest. (At one point, you will make it to the outside and grab the vest for additional protection.)

Move around the room using the cursor keys. To run or make fast turns, press and hold Shift while pressing the cursor key for the desired direction. (You can run backwards, too.) Try sidestepping. This is done by pressing the middle mouse button (default assignment) or by holding Alt while you press either the left or right cursor keys.

Sidestepping is also useful when moving down corridors with sharp turns. Rather than making the turn while facing forward, approach the turn by sidestepping in a peek-a-boo sort of way. In this manner you have a wider perspective around the corner, which is good, for you never know who or what may be lurking there. Sidestepping is also a great way to get out of the way of incoming projectiles while retaining your view of the enemy, or for strafing a group of bad guys with a swath of bullets.

In your tour of the room, notice that there are blue flasks, slime barrels, and odd looking “helmets” lying around. The *blue flasks* are enzyme potions that give you a slight health boost. The *helmets* are Spiritual Armor that enhance your level of protection to withstand projectiles and physical combat.



Pick up objects by simply walking over them and notice how your health and armor percentages increase in the Status Bar at the bottom of the screen. Pick out targets in your field of view and press Ctrl to fire a few shots. You want to get the feel of the handgun and also measure your aim and accuracy. Stand several feet away from a slime barrel and shoot at it. After hitting it a few times, it will explode.

TIP

Barrels can be a great weapon when monsters are near one. Rather than shooting it out with every single monster, aim for the barrel. Aim well and you'll get a gut shower.

To the left of your original entrance spot, and following along the wall, you will see a small room with some stairs. Walk up these stairs. (Notice how your visual perspective changes according to your elevation.) At the top of the stairs, there is

a green Security Armor vest. The vest is sitting atop a raised blue column that appears to rotate. Walk right up to the column and grab the vest. You can even climb on the column if you like.

When you are ready to confront the enemy, run down the corridor directly across and to the right of your initial point of entry, past the large open windows on the right.

You will come upon a metal gate. Open the gate by pressing the spacebar.

Carefully, step inside and begin taking aim at the former human Marine across the room. He has noticed you and is taking aim at you. Fire by pressing Ctrl. If you aim well, the former human will collapse a bloody mess. Run around the room exploring every corner and picking up beneficial artifacts. Remember to sidestep and use your full range of motion.

Our little guided tour ends here. You can take matters into your own hands now. But it is fitting to mention that, throughout Doom, there are numerous secret doors, wall switches, and triggers. *Secret doors* usually give way when you push on them by pressing the spacebar—but certain doors, whether secret or not, will not open until you activate a *switch* or a *trigger*. Switches and triggers activate some event, like the raising or lowering of platforms (or the opening of passageways that were previously inaccessible).

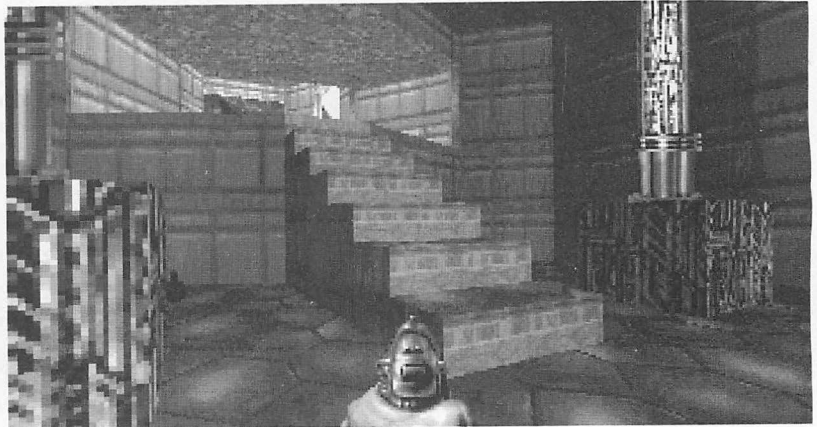
**TIP**

After a killing, it's usually a good idea to walk to the body and take any unspent ammo. In some cases, you will be able to take the corpse's weapon too.

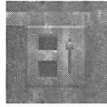

Switches are normally found along walls. Triggers, on the other hand, give no indication of their presence. A trigger can activate a secret door or a platform when you walk past it.

SECRET DOORS AND SWITCHES

A secret door can usually be distinguished from a regular wall by its color and texture. Sometimes secret doors are found near a light source. If you are unsure as to whether a wall is a secret door, try it. Walk up to the wall and press the spacebar. Then see what happens next. If the wall gives way, you've stumbled upon a secret door. But don't be overly jubilant. Usually, behind secret doors there are some pleasant surprises. But often you might come face-to-face with some ugly and unfriendly creature. As for switches, when you see one, it is usually best to activate it. Activate a switch in the same manner that you open a secret door—by pressing the spacebar.

By now, your feet should be sufficiently wet. It's time to venture forth on your own and begin your own exploration of Doom. Play it and get some practice; you'll get blown away soon enough to make you wish you'd already memorized the rest of the book. You'll be back, with questions. The next chapter, "More Doom Basics (In Phobos No One Can Hear You Scream)," provides more instructions on the program aspects of the game (like saving your game, loading different scenarios, skipping ahead or back in the game, and upping your protection). Other sections of this book discuss in-depth strategy for every episode at every level, give you helpful pointers, and explore the lethal and wondrous universe of Doom in technical detail.



**MORE DOOM
BASICS (IN
PHOBOS NO
ONE CAN HEAR
YOU SCREAM)**

T W O

You are now in Phobos but soon you could be in Hell. Literally and figuratively. So it's a good idea to stop for a second and orient yourself. If you're already familiar with the Doom menus and the setup options and know the enemy well, and all you want is the lowdown on the level you're interested in playing, you can skip the following amenities. Just flip over to Chapter 3, "The Doom Episodes and Level Maps," and look up what you need.

However, if you want to go over the basics, then continue with this section. These are the topics we cover here:

- How to use the Doom menu
- Who your enemies are and how tough they are
- What weapons and other aids you can use
- How to read the Status Bar
- Basic skills and strategy

If, in addition to the above, you want to know about setup options, like selecting a soundcard or a joystick, or initiating MultiPlayer modes, then refer to Appendix A, "Installing and Troubleshooting Doom."

HOW TO USE THE DOOM MENU

After you start Doom (by switching to the directory where Doom is installed and typing **DOOM** at the DOS prompt), you will see the initial Doom screen, then a demo will start automatically. If you haven't played Doom before, it is a good idea to sit back for a minute and watch the action unfold. Anything can happen in the demo. It may start in any episode and in any level. The marine can get into a tight situation

and die almost immediately. However, it is possible that he can overcome the odds and wipe out a number of monsters before biting it. (There are three Doom episodes and nine levels in each one. Shareware users only have access to the first episode.)

To bring up the main menu (the DOOM menu) while the demo is running: Press the spacebar on your keyboard. (To bring up the main menu once you are in the middle of a real game, you would press Esc.) Figure 2.1 shows the Doom main menu.



FIGURE 2.1 *The main menu in Doom*

Once the main menu appears you can choose any of the options by moving the skull that's hanging out to the left of the options. Move the skull cursor (using the up and down arrow keys, the mouse, or joystick) to the selection you want, and activate the selection by pressing ↵, the primary mouse button, or the joystick's fire button. (Some menu actions can be activated through a function key. We'll get to that soon.)

Once you activate a menu selection, you could be led to a submenu of additional options. To get back to the original menu, press Backspace. To exit the menu(s) completely, press Esc.

The rest of this section discusses each menu option, its function, and its keyboard equivalent.

NEW GAME

Select New Game whenever you want to choose an episode and level to play and plunge right into the action. After choosing New Game, you get to choose one of the three Doom episodes, as shown in Figure 2.2:

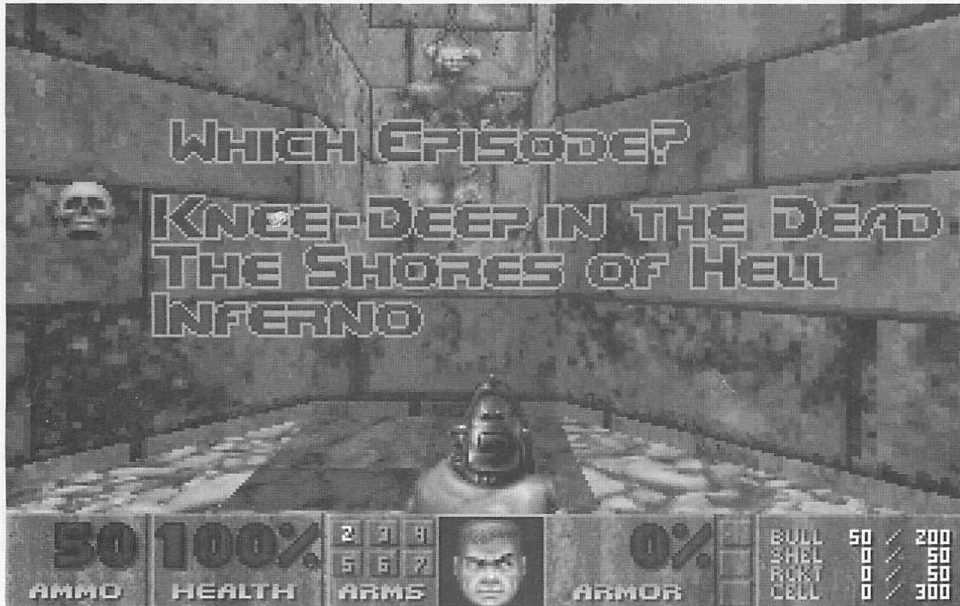

FIGURE 2.2 Episode selection screen

Choose an episode. (Remember, the shareware version only lets you choose the first episode.) Finally, choose the level of difficulty. In the latest version you have five choices:

- I'm Too Young to Die
- Hey, Not Too Rough

- Hurt Me Plenty
- Ultra-Violence
- Nightmare

Select a level. The game will start momentarily.
Good luck. Nice knowing you.

USING THE OPTIONS MENU

The Options menu lets you control various aspects of the game. You can change these settings now or you can come back to them later in the game as your needs become evident. (Remember, to get to this screen in the middle of a game you would press Esc to display the main menu, then choose Options.)

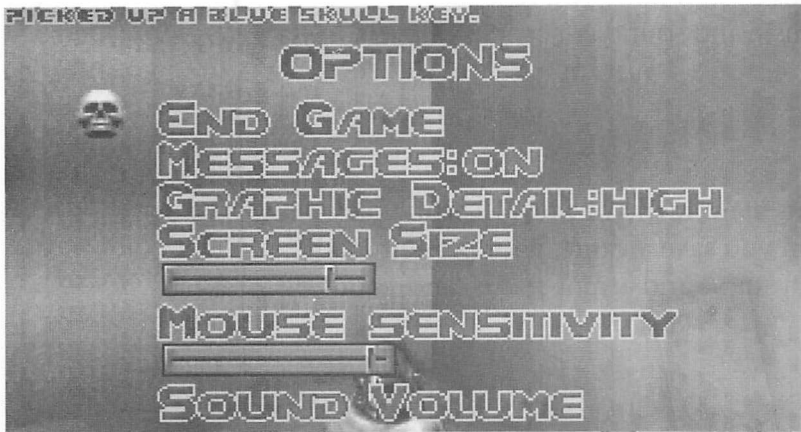

End Game (F7)

Choose **End Game** or press F7 to stop the game you've been playing. End Game does not take you to DOS. It leaves

you in Doom so you can make additional selections.

Messages (F8) Any time you pick up an object in Doom (weapons, Medikits, ammo, and other aids and gadgets), you can see a message in the upper left corner identifying the object you grabbed. Select **Messages** or press F8 to toggle between Messages On or Messages Off.

Graphic Detail (F5) Doom gives you two selections for graphics: high and low. The default setting is high. With slower machines and video cards, switch to low graphics if the action seems jerky.

Screen Size (+) and (-) Select **Screen Size** and then slide the switch below with the cursor keys or by sliding the mouse to increase or decrease the size. (You can also simply press + or - while playing the game for the same results.) On slower systems, decreasing the screen area may improve smoothness and animation quality.

Mouse Sensitivity This option lets you fine-tune the sensitivity of your mouse control. Slide the **Mouse Sensitivity** switch with the up and down arrow keys (or using the mouse as described for the Screen Size control) to the adjustment you need.

Sound Volume (F4) This option takes you to a sub-menu where you can adjust the music and sound effects (SFX) levels independently.

SAVE GAME (F2)

Select Save Game from the Doom main menu or press F2 while playing to save the current game. When you save a game, your present load of weapons and ammo, your health status and armor status, and your current position are all saved automatically. The purpose of Save Game is to allow you to pick up a game at a certain point rather than at the very beginning.

After selecting **Save Game**, you get to type a name for it. Notice that there are six slots to save your games. This means that you can save up to six different games from this or other episodes and levels. (Or you could save your current game starting from up to six different points—say after going down this corridor for one, after passing through this doorway for another, etc.)



TIP

You might want to save your game right before you attempt to do something that could harm you or even kill you. That way, should the worst happen, you can simply load the saved game and try the maneuver again or opt for something else.

To save your game, move the cursor next to the slot you want and press ↵. Then type any description you like for the game. You can backspace over existing characters if you need to. Press ↵ to accept the new name. When you are finished saving your game, press Backspace to return to the Doom main menu, or press Esc or ↵ to return to the action.

The F6 Key: Quick Save After you have saved a game once, you can update the situation reflected in the saved game by “Quick Saving” to the same game name. You do this by simply pressing F6. Note that this *overwrites* the previously saved situation. As a precaution, when you press F6 you will be prompted with something like “Quick Save over your Game ‘E11M2?’” Type **Y** to accept the quick save; type **N** if you do not wish to save the game at this time (or, more importantly, with this name). In either case you are then returned to the game.

LOAD GAME (F3)

Any time you want to pick up a game from a particular episode and level that you saved beforehand, select **Load Game** from the main menu. (Or, while playing a game, press F3). You will see a list of up to six games that were saved earlier.

Select the game you want. Then press Backspace to return to the Doom main menu, or Esc to leave the menu.

READ THIS

Choose **Read This** from the main menu to find out how to order Doom for your friends and for brief instructions for playing and getting around in Doom.

QUIT GAME (F10)

Select this option to leave Doom altogether and get back to the mundane world of DOS. While playing a game, press F10 for the same purpose.

HOW TOUGH IS MY OPPOSITION?

To coin a phrase and give you a quick answer to the question posed in the heading here, “tougher than rusty titanium nails.” You’re not facing an ordinary enemy. These guys are Space Anomaly miscreants. We’re talking beings from another dimension. We’re talking rejects from the pits of Hell. They’re ugly, they’re mean, they’re right-out vicious. ...They’re really weird aliens bent on killing, and they’re not registered with the Immigration Service.

As we prepare to take a look at the formidable foes you face, the words of Sun-Tzu, an ancient Chinese general, come to mind. In his much-cited *The Art of War*, Sun-Tzu wrote (in or about 2500 B.C.):

“If you know the enemy and know yourself, you need not fear the result of a hundred battles. If you know yourself but not the enemy, for every victory gained you will also suffer a defeat. If you know neither the enemy nor yourself, you will succumb in every battle....”

These words ring ever so true. Even in the lunar research facility on Phobos. Without further fanfare, then, here is the ghastly line-up:

Former Human Some of these guys were your fellow grunts at one point. Why, some of them might even owe you money. You might have thought they were lost to the gateways—the stupid fools. But they’re back. And there’s no reasoning with them. Former Humans are hell-bent on dragging you down and seriously pounding on you. You can usually dispose of a Former Human with a single bullet through a vital area. Of all your enemies, Former Humans are the slowest and least powerful. But never underestimate them. They fire real bullets and they hurt real good. Depending on where you get hit, you will experience a slight decline in your health and armor from 1 to 15 percent.



Former Human Sergeant These guys make the Former Humans look docile by comparison. Former Human Sergeants are really, really tough. They might have been human at some point, but now they're more beastly than anyone you care to know. Funny how they resemble sergeants you once knew and hated. Funny how you still hate them. Depending on how well you aim, you can normally stop a Former Human Sergeant with a solid shotgun blast or a single bullet in the chest or head. Former Human Sergeants are faster and more persistent than mere Former Humans. It must be the rank. If you get hit by a shotgun shell from a Former Human Sergeant, you will sustain a health and armor decline in the range of 9 to 45 percent.



Imps No, this is not your mischievous little devil with a fork and pointy arrow tail. Imps are bad news. An encounter with one or more Imps is never pleasant. Imps can tear you apart with their razor-sharp claws, shaving off anywhere from 3 to 24 percent of your health and armor. They are also able to heave scorching fireballs guaranteed to sear and sizzle, burning off 3 to 24 percent. You'd better have a good sidestep technique to avoid being toasted. Like a Former Human Sergeant, an Imp can be picked off with single shotgun blast—if it is placed squarely in its mouth. When shooting an Imp from a distance, two or three good hits with a shotgun is about what it takes. Taking down an Imp with a handgun requires about five well-placed shots. Imps aren't exactly speedsters, but their jerky motions and fireball heaving powers make them fearsome opponents.



Demons Picture a shaved gorilla with horns and saw-like teeth. Now make him dumb and strong as a Mack truck. There you have it. That's a Demon. The stampeding charge of a Demon and its cruel bite make this dude particularly deadly. A single chomp can reduce your health and armor by a good 4 to 40 percent. The preferred method for dealing with these nasty creatures, especially at close quarters, is to be



equipped with a hungry chainsaw. Getting close to a Demon under any other circumstances spells suicide. If your aim is really good and the distance is reasonable, you should be able to put Demons away with two or three shotgun shells. Fighting a Demon with a handgun is never recommended. You'll just piss him off even more. Demons are the fastest of the biped creatures you will encounter. They can charge at full speed in the blinking of an eye. If you don't have a chainsaw, your best option is to run backwards and pump a couple of shells in his direction.

Specters Specters are particularly tough because you never know where they're coming from. Their partial invisibility and speed makes them among the most elusive of Doom's creatures. Like Demons, Specters are fast and will charge you, inflicting 4 to 40 percent damage with each charge. If unchecked, a Specter will devour you alive. Focus your concentration and always keep an eye out for a Specter. The way to spot a Specter is to look for a slight visual disturbance. That's the Specter's telltale signature. Here, too, the shotgun can be your trusted friend. Two or three shots at medium distance is the recommended daily allowance for one such Specter. But you must be really quick and accurate. The chaingun is also effective. But a fast-moving, partially invisible creature makes a most difficult target. Often you don't see a Specter until it is right in your face. Then it's chainsaw time.



Lost Souls These flying horned skulls on fire hover slowly until they spot you. Then they swoop down kamikazi-style and put a scorching clamp on you, draining health and armor from 3 to 24 percent. The best way to deal with Lost Souls is from a safe distance. If your aim is really good, you can blow away a Lost Soul with two or three shotgun blasts between the eyes. Otherwise, if you've got a good supply of ammo, it's best to reach for the reliable chaingun and spray the Lost Soul with a steady stream of bullets.



Cacodemons Now, this is some monstrosity. The multi-horned, one-eyed Cacodemon floats majestically, belching lethal lightning balls like there was no tomorrow. And should you get hit by one, you can rest assured there won't be. Though lacking the speed of a Lost Soul, Cacodemons can move at a decent pace. If one of their lightning balls doesn't fry you, its man-size bite will crush you, chomping away 6 to 60 percent of your health and armor.



When facing one of these unsightly creatures, pray you have a well-stocked chaingun in your possession. Even though these beasts can be killed with heavier weapons, the chaingun lets you spray a Cacodemon full of lead before it can belch its fulminating thunder ball. Rockets are also most effective against Cacodemons, but good aim is essential. Usually one or two will do the job. Also, if you have a Plasma Rifle, three to five square charges will deflate the dreaded Cacodemon.

Barons of Hell These creatures are pure hell. Seriously. They resemble extremely irritable minotaurs. Solid mutant muscle, brute strength, and single-mindedness make the Barons of Hell perhaps the toughest enemy you will face. A single claw caress from a Baron will tear away 8 to 80 percent of health and armor. But Barons of Hell can also sling energy charges. A paralyzing energy blast will zap 8 to 64 percent of your health and armor. Your first meeting with a Baron of Hell may well be your last.



How to dispose of a most unkindly Baron of Hell? Have you five rockets to spare? You will need each and every one. The plasma rifle or the BFG 9000 are also effective against the Baron.

With a plasma rifle, you must unload the equivalent of about 50 cells, give or take a few depending on your ability to connect full-impact hits. If you are fortunate enough to have a BFG 9000 handy, you'll only need a single discharge, the equivalent of 40 single cells, to get the job done.

The Baron moves fast, too. If he closes in on you, you have but a few precious instants to make your peace with God.

Cyberdemon Go ahead and pinch yourself. This is no ordinary nightmare. Your first view of the formidable Cyberdemon occurs in The



Tower of Babel level from the Shores of Hell episode (episode 2, level 8). Talk about lasting impressions. And it's not just the Cyberdemon's size that's frightening. (A Cyberdemon could crush you like a grape if he stepped on you.) A Cyberdemon is a hybrid creation, an amalgamation of hardware and organics making up one totally tough robo-monster. The Cyberdemon's left arm has been enhanced with a high-power rocket launcher and he seems to have an inexhaustible supply of rockets. A single

rocket from the Cyberdemon can blow away anywhere from 20 to 160 (yes, 160) percent of health and armor.

The best way to deal with the Cyberdemon is not to deal with him directly, but to make him fight other monsters (like the Barons of Hell and the Spider Mastermind). The strategy section for episode 2, level 8 tells you how you to accommodate Mr. Cyberdemon. If there are no monsters around to take on the Cyberdemon for you, then you must rely on a combination of all your heavy weaponry. The Cyberdemon will collapse under the pounding of about 200 plasma rifle shots. With a BFG 9000, all you need is 4 well-placed hits. If you have about 20 rockets, you must unload and connect with every single one. The only trouble is finding the time to deliver them when you are under the barrage of the Cyberdemon's rocket shower. If you manage to escape an encounter with the Cyberdemon, pinch yourself again. You could be dreaming.

The Spider Mastermind Can this crawling aberration be the brains behind the mayhem? It makes you wonder. Was the discovery of the Anomalies purely accidental? Or are there darker machinations here at play? Perhaps you can't answer these questions now. And answer-

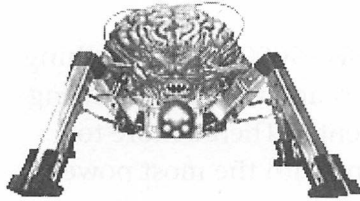

ing questions will be the last thing you'll want to do when you confront the Spider Mastermind. Equipped with an ultra-speed machine gun, this cyber-organic miscreation is truly unstoppable. You'll need to enlist the aid of those you've been trying to annihilate all along. This is a situation

where you might actually be happy to see a horde of Cacodemons and the dreaded Cyberdemon. See the strategy section "Make Them Kill Each Other" at the end of the chapter. A word to the brave: Don't even think about taking on Mr. Spider Mastermind alone unless you have a full supply of cells and rockets and all the health and armor you can stand. To stop this creature you will need 3 blasts from a BFG 9000, 150 shots from a plasma rifle, or 15 rockets.

YOUR ARSENAL

As mentioned at the outset, you start each new game equipped with a humble, but reliable, hand pistol. As you make your way through the labyrinthine corridors and surreal Doom landscapes, you must make every attempt to pick up more powerful weapons, ammo, Medikits, and any other useful electronic gadgets and spiritual aids. Everything you pick up can make the difference between life and death. You also get to keep all the weapons and items you've picked up if you make it to the next level.

There will be times when you run into more ethereal artifacts that might well have made their way through the gateways. These curious artifacts can give you anything from a quick health boost to a spiritual armor lift. Some of the rarer artifacts can render you momentarily invisible and, at times, even completely invulnerable. The next few pages give you the lowdown on the weaponry, the ammunition, and other bodily and supernatural artifacts you might find.

THE WEAPONS

"I don't want no high school queen

All I want is my M16."

—Marine Corps formation chant

From the lowly hand pistol to the advanced BFG 9000, and everything in between, in Doom you can't afford to overlook any weapon. Knowing your arms and what they can do is simply elemental. There's more to choosing a weapon than simply grabbing the one with the most power. You have to take into account the enemy you face, your surroundings, and, also, your ammo usage. You could wind up kicking yourself when, confronted with a Baron of Hell, you discover you only have three rockets in your possession.

It is no oversimplification to say, then, that your arms will, to a large degree, determine your moves and strategy. Here are the weapons for your inspection.

Shotguns Shotguns are the standard-issue weapon. Though they fire at a slower rate than a handgun, shotguns deliver a powerful blow at medium distances. At close range, a shotgun makes short work of Imps, Former Humans, and Former Human Sergeants. A Demon normally takes a couple of shotgun blasts before going down. At a distance, shotguns still carry a hefty bang for your buck. Never shun a shotgun you can nab. This weapon is your workhorse. Treat it and appreciate it like one. Usually when you kill a Former Human Sergeant, his gun will be available for the taking. Take it! You will get 4 shells added to your supply. However, if you find a "placed" or hidden shotgun, you get a total of 8 shells. (If you are playing at the lower difficulty level, "I'm Too Young to Die," you get twice the amount of ammo per shotgun.)

Chainsaw What's a chainsaw doing on a Martian moon? This is no time for silly questions. If you pick up one along the way, you'll be glad you did. This crude logger tool can be a most welcome addition to

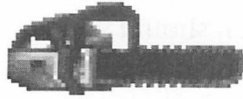

your arsenal. At close range few weapons can be as effective as the chainsaw. Charging Demons and Specters cannot get past the sharp turning blades of the antiquated-yet-effective chainsaw.

Chaingun A chaingun spitting bullets by the mouthful comes in handy when you walk into a roomful of inhospitable hosts. Although its punch is less than that of a shotgun blast, it's the chaingun's rate of fire—like



that of a machine gun—that can overpower some enemies. Besides its usefulness in crowded situations, a chaingun might well be the best way to confront Cacodemons and Lost Souls. The bullet shower might keep a Cacodemon from working up a thunderous ball-lightning. Lost Souls are susceptible because they hover for a few instants before swooping down. That's the time you should douse them with bullets. The main drawback of relying too much on the chaingun is its voracious consumption of bullets. So keep a watchful eye over the Status Bar and a steady finger on the trigger. Any chaingun you find comes with 20 bullets.

Rocket Launcher Now we start to get into some serious fire power. There's nothing quite like a rocket launcher to clean out a room of unwanted guests. A single well-placed rocket redefines the expression "taking out the trash." If you find a rocket launcher, your fighting



chances might not look so bad after all. A rocket launcher comes preloaded with 2 rockets. Once you have one in your possession, use it sparingly, and only when you need it. It takes 5 direct rocket hits to finish off a Baron of Hell. A Cacodemon *may* succumb to a single rocket if landed squarely in its eye (but even then only if he's already injured). The Cyberdemon on the other hand can eat a hefty dose of rockets before feeling any effect; the magic number for the Cyberdemon is 20. Just hope that you live long enough to count that far.

Plasma Rifle This is a beauty. A plasma rifle is a highly coveted device, especially considering some of the circumstances you will find yourself in. Plasma rifles work on plasma energy cells and can handily liquefy most threats, real or imagined. As with a rocket launcher, should you find a plasma rifle, use it well and use it wisely.



Who knows when another cell might be available. Don't waste it on creatures that can be taken out with lesser weapons. A Baron of Hell will fold after receiving the impact of 50 plasma blasts.

BFG 9000 The crowning jewel in the military's assault arsenal, the BFG 9000 evaporates anything within sight. This fine piece of Union Aerospace Corporation craftsmanship can really make your day. You'll be grateful to have one in your hands when you get

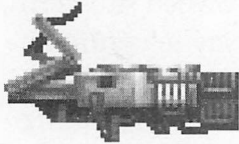

to the higher Doom levels. If you are fortunate enough to have a BFG 9000

with a generous supply of cells, you might just have some glimmer of hope when confronting the nasty Barons of Hell (1 blast), the formidable Cyberdemon (4 blasts), or the sinister Spider Mastermind (3 blasts).

WARNING

Use caution when firing rockets. If you are standing too close to a wall and aren't sufficiently armored, the blast might be a little too much for you (or anyone).

THE AMMO

Scattered through the installations, you will find a variety of ammunition for all the weapons you can carry. Keep an eye on the Status Bar and go only for the ammo you need. Remember that there is a limit to how much you can carry at one time. Smart players will avoid expending precious energy chasing ammo they can't use. On the other hand, not arming yourself sufficiently can be costly or fatal. If you are playing at the level of least difficulty ("I'm Too Young to Die") you will get double the

amount of ammunition. Here is the ammo you should keep an eye for:

Clips Your handgun and your chaingun aren't much use without bullets. Bullet clips can usually be found near the fresh corpse of a former Former Human, but they're often just scattered around. Pick up a clip and you can add 5 bullets to your favor. The ammo *box* contains 50 bullets. They are hard to pass up.



Shells If you know your weapons well, you'll be using your shotgun overtime. The importance of keeping a full load of shells is something you should remember from your early days in boot camp. So if you are not carrying shells to full capacity, take every chance to pick up a 4-pack of shells. A shell *case* adds 20 shells to your count.



Rockets There are certain monsters, like the Barons of Hell, that are nearly impossible to overcome. So if you find a rocket, grab it. Save it. You will need it at some crucial point. Remember that a Baron of Hell needs about five before knocking out for the night. If you run into a rocket *case*, you will be increasing your supply by a handsome dividend of 5 rockets of pure explosion power.



Cells A cell provides the juice that powers the plasma rifle that pulverizes, plain and simple. Cells also juice up the BFG 9000. One cell is good for 20 plasma rifle shots. To get the BFG 9000 to power up even once, however, you need a total of 2 cells. A *bulk cell* contains the equivalent power of 100 single plasma blasts.



ELECTRONIC GADGETS

These handy devices are very hard to come by. When you see one, pick it up and put it to good use.

Light Amplification Goggles

Did someone turn up the light? No. You're just wearing jeepers, creepers, where'd you get those light amplification goggles. These marvels of optical technology are particularly effective when you can see your opponents but they can't see you because it's too damn dark. The light amplification effect from the goggles only lasts 120 seconds.



Maps

Your ordinary *map* (referred to as the *Automap* because it automatically updates itself to show your current position) is available by pressing the Tab key. When the Automap is on, your screen is replaced by a top view of the installation you are in. Your position in relation to your surroundings is revealed as a small white arrow, which points in the direction you are facing. Press Tab again to return to the normal view.

With the ordinary Automap, you only get to see the portion of the installation you have visited so far. Once you've picked up a *Computer Level Map*, on the other hand, pressing Tab displays a complete view of the level anytime you want it. Pressing Tab again returns to normal view. The view includes all secret doors and passageways delineated in yellow. Also, areas where you haven't been yet will appear in gray.

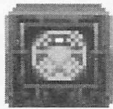

Because the Computer Level Map can play a key role in helping you solve puzzles and plan your moves, and since it is a simple yet sophisticated device, it behooves you to take a minute to get acquainted with its controls:

Follow Mode (F) Follow mode is simply the ability to move while viewing the Automap. Normally, Follow mode is turned on. This

means that you can continue using your controller (keyboard, mouse, or joystick) to move yourself about. Toggle the Follow mode on and off by pressing **F**. Turning Follow mode off allows you to move the *map* around the screen with your controller instead of moving yourself. This makes it easy to see other areas of the map besides your immediate surroundings.

Map Magnification (+ and -) Pressing + causes the map to enlarge so you can more closely inspect an area of interest. Conversely, pressing - causes the map size to decrease, letting you get a view of the installation in its entirety.

The Grid (G) You can overlay a grid on the Automap to isolate sectors and get your bearings. The grid is toggled by pressing **G**.

Auto-Spotting (M and C) The Auto-Spotting feature is very useful. It allows you to mark places to which you might want to return later (like the location of a Medikit, for instance). Any time you wish to mark a place, simply press **M**. A digit marker will appear on the map, on the spot where you currently find yourself, starting with the number zero. Each time you mark a new spot, another digit will appear, each time incrementing by one. Mark your map judiciously, because you can only mark it a total of ten times. Any time you wish to clear any marks from the Automap, press **C**. Then you can start marking it again.

BODILY AIDS AND SUPERNATURAL ARTIFACTS

Here is a rundown of the other beneficial items and artifacts you might find throughout the Doom installations. These items can be categorized into *medical*, *protective*, and *supernatural*. The first group helps you heal when you are hurt. Protective items increase your resistance to onslaughts and attacks. Supernatural artifacts can give you quick health lifts, cloak you in invisibility, and even render you invulnerable.

THE MEDICAL AIDS

Stimpack Pick up one of these for a quick pick-me-up. The booster enzyme injections in a Stimpack often make the difference between clinging to life and escaping certain death. A Stimpack will give you 10% additional health.



Medikit If a Stimpack is a quick pick-me-up, a Medikit is much more. In this package you'll find bandages, antitoxin compounds, and other medical supplies. A Medikit can increase your health a significant 25%.

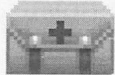

Berserk Pack Find one of these and know, for a few moments anyway, what it feels like to be superhuman. A Berserk Pack heals you and shoots you full of high-grade adrenaline, quickening your reflexes and enabling you to tear apart opponents limb from limb using nothing but your bare hands. The Berserk Pack gives you physical prowess beyond the human scale. While under the Berserk effect, your vision will be slightly reddened. If you come upon the Berserk Pack, you will enjoy its effects for the remainder of the level.



TIP

Look at the Status Bar, notice the condition of your face, and take a look at the Health read-out. If you are in trouble, don't wait too long: retrieve every Stimpack and Medikit you can find before it's too late. Don't let your health reach a level below 25% or you may not survive the next Imp or Cacodemon onslaught.

THE PROTECTIVE ITEMS

Armor If the Armor read-out on your Status Bar is less than 100%, you can grab a Security or Combat Armor to bring it back up. The green *Security Armor* vest is made of lightweight Kevlar and is ideal for riot-control type situations. It might give you the slight edge in protection that you hope will make the difference. The purple *Combat Armor* vest, also called the "mega armor," is built for heavier action. Its titanium



derivative construction makes it twice as effective as the Security Armor. Pick one up and see your armor level soar to 200%.

Note that you can't pick up any additional Security Armor or Combat Armor vests to exceed their standard 100% and 200% protection; in

NOTE

It is not possible to build up your percentage by accumulating more than one armor. But you can "switch" a Security Armor for a Combat Armor (by simply picking up a Combat Armor when you find one), which effectively raises your armor to 200%.

other words, there's no benefit to trying to collect more than one of the same kind of armor unless you've dropped below their standard protection level. However, you *can* increment your armor level beyond the standard by picking up *Spiritual Armor* artifacts (the odd-looking helmets). With each artifact, your armor level will increase by a factor of 1%.

Radiation Suit It's not only stuffy in the Phobos installations, it's right-out radioactive. There would be days, your mother told you, that you'd find yourself up to your waist in toxic ooze. Thank God for radiation

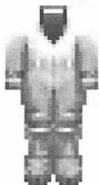

suits for days just like these. Don a radiation suit and for 60 seconds you can wade in the radioactive pools and canals that crisscross many of the installations. These ooze sewers may be the only way to find wall switches and secret passageways. Your view will be slightly green while the radiation suit is active. Just before de-activating, the screen will flash green.



Backpacks The backpack is truly a godsend. It effectively doubles the amount of ammo you can carry for every weapon. In addition, this lucky find also comes loaded with some extra ammunition: 10 bullets, 4 shells, 1 cell, and 1 rocket.

SUPERNATURAL ARTIFACTS



Health Potions These small blue flasks can be found scattered about in most levels. A health potion will give you a 1% boost in health even above 100%.



Spiritual Armor These odd-looking helmets raise your armor by 1%, even above the 200% mark that you can reach by donning the Combat Armor.



Soul Sphere While it may not give you a new body, a Soul Sphere will cause your health level to soar 100%, to a maximum of 199%. You'll feel like a new man because you practically will be a new man.



Blur Artifact This curious orb renders you virtually invisible. While the monsters might still catch a glimpse of you, their attacks will be less than accurate. Take advantage of your invisibility, for it only lasts 60 seconds.

Invulnerability Artifacts Fortunately for you, not everything leaking out of the Anomalies is green and slimy or mean and



deadly. The Invulnerability artifact will make you invincible, at least for a short time. While short in duration (60 seconds), you will be able to inflict most serious damage upon any and every thing that crosses your path. While under the effect of the Invulnerability artifact, you will see everything as a "negative" image. This makes it a bit hard to maneuver, but you'll agree that's a small price to pay.

THE STATUS BAR AND WHAT IT TELLS YOU

Any time you start Doom, you will see the Status Bar across the bottom portion of the screen. The Status Bar is a key instrument, made up of seven panels, as shown in Figure 2.3. It keeps you abreast of vital functions and tells you, at any given moment, how your weapon and ammo supplies are holding out.

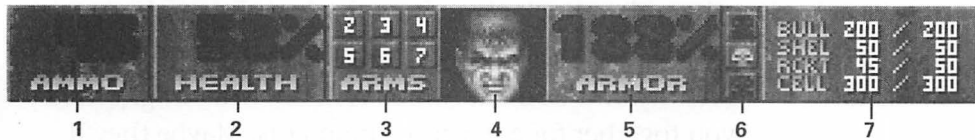

FIGURE 2.3 *The Status Bar*

From left to right, here is a description of each panel:

1. Ammo This box tells you how many rounds you have left for the weapon you happen to be holding at the current moment.
2. Health This read-out shows the status of your health. Normally, you start out with 100% of your health. But as you begin to take serious abuse and pounding, your health will decrease.
3. Arms The highlighted (or bright) numbers in this display tell you which weapons are available to you. You can switch to any weapon you possess by pressing its number: 2 = Handgun; 3 = Shotgun; 4 = Chain-gun; 5 = Rocket Launcher; 6 = Plasma Rifle; 7 = BFG 9000. There may be situations when you have a particular weapon but no ammo to make it work for you. The reverse is true too. You could have several rounds of ammo for a weapon that is not currently in your possession. The weapon assigned to 1 depends on whether you have gotten the chainsaw or the Berserk Pack.

4. Your Mug Yeah, you're handsome. But don't let it get to you. Your life's at stake. But even worse, the whole future of civilization as we know it could be in serious jeopardy. Your face will show you just how good or how terrible you're feeling. The more intense the pounding you take, the more you will begin to look like a prizefighter at the end of a long career. When you get shot, but are uncertain as to who shot you or where the attack came from, look at the marine's eyes. They will turn in the direction of the attacker.
5. Armor Security and Combat Armor vests are what might hold you together for a few more moments. Maybe they'll carry you through the worst part of an episode. By picking up Security or Combat Armor, you can amass as much as 200% armor. Also, the Spiritual Armor helmets will help by adding 1% to your total armor incrementally (even above 200%). Plenty of armor translates into plenty of protection, and you can never have enough of that.
6. Keys This area of the Status Bar shows any or all three of the keys you might have picked up. Keys are important because without them, some latches and doors simply won't open. Often a key will open a door that leads to a switch. The switch may be what you need to uncover another secret passageway, platform, or sunken bridge.
7. Total Ammo The far right side of the Status Bar shows you the current and the maximum number of rounds you can carry for each projectile type. The column on the left of the diagonal tells you how many you have, and the column on the right shows the maximum you can carry. You can effectively double the quantities of projectiles you can carry if you are lucky enough and smart enough to procure a backpack.

THE ART OF WAR IN DOOM: SKILLS AND GENERAL STRATEGY

"While heeding the profit of my counsel, avail yourself of any circumstances over and beyond the ordinary rules, and modify your plan accordingly."

—Sun-Tzu, *The Art of War*

There are some very important and basic points of strategy that you should observe regardless of the episode and level you are playing. This is because your objective is always the same: to try to make it out alive and onto the next level. The importance of a sound strategy cannot be overemphasized. Sure, you can have a whole arsenal of weapons and a generous supply of ammo at your disposal and you can simply wing it. Just go out there and shoot it out. The last player or thing standing wins. But the point is, without an effective strategy, even a BFG 9000 amounts to a very expensive and useless gadget.

Smart players know how to make the most of their strengths and how to minimize their weaknesses. All strategies, however simple or complex, can basically be divided into three main categories: *moving*, *fighting*, and *exploring*. You need to be able to move well to get to where you want to go. You also need to know how to fight under different conditions. Finally, to solve the puzzle of your surroundings, you need to explore, test hypotheses, and draw conclusions.

In addition, each Doom level may require you to devise another set of techniques and approaches just to make it through. There are some instances in Doom where only a certain technique will work. In addition, you may have only one chance of executing it. Your challenge is to find the technique, develop it, and execute it flawlessly.

Without further preamble or hyperbole, here are the basics of strategic moving, fighting, and exploring.

MASTERING YOUR MOVEMENT

To amount to anything in Doom, it is imperative that you develop a good technique for moving around. Whether you are on Phobos, Deimos, or even the surface of Hell itself, running, turning, and sidestepping are all

very important. Of course, you can combine any of these motions so that you can run backwards or strafe to either side rapidly.

To gain mastery of your movements, play Doom on some of the lesser difficulty levels. Pick targets and practice moving to them. Practice turning around rapidly by pressing Shift and either ← or →. You can also add the quickness of the mouse to your keyboard combination by tracing a fast circle in the direction of your turn.

Practice sidestepping around corners. Strafing can help you see a monster around a bend before it has had a chance to fire at you or charge you. After you get some level of confidence using independent movements, try putting them all together. For instance, try running forward. Then make a quick 180-degree turn and continue running backwards in the same direction. This technique can pay handsome dividends when you play Doom in Deathmatch mode over a network or serial modem.

The ability to move well in Doom will help you plot a more flexible strategy. It's simple: a facility of movement translates into more options for you.

FIGHTING

Even though there are many ways to fight off attackers, some ways are more efficient than others. You may discover your own unique ways of dealing with Doom's monster mash. This section covers the essentials.

Get a Shotgun, Quick! As mentioned in "Your Arsenal" earlier in this chapter, the shotgun is your workhorse. Obtain one as soon as possible. Then learn to use it, and use it well.

Whenever you start a level holding only a handgun, and especially if you are surrounded by a ghastly gang of goons, do not waste time fighting Demons or Imps with it. You stand a good chance of taking unnecessary hits. Your health could deteriorate rapidly and all could be lost in a matter of seconds.

NOTE

Should you happen to get killed in the middle of a level, even if you had accumulated various weapons from previous levels, you would be forced to start the level fresh, packing nothing but a handgun.

Instead, run away. The best thing to do at this point is to concentrate your efforts on finding and shooting a Former Human Sergeant. These guys are basically walking shotguns. Shoot the first Former Human Sergeant and take his shotgun. You'll stand a much better chance of surviving.

Shoot the Barrel If a group of monsters is near a toxic waste barrel, they are prime matter for an explosive splash. Use the barrel's explosive potential to your advantage. Shoot it. The ensuing explosion will make confetti of anything standing nearby. Usually a single solid shotgun blast will set off a barrel, which in turn might set you free. At least for the time being.

Make Them Kill Each Other That's right. You can cause the Former Humans, the Imps, the Barons of Hell, and all the other creatures to turn on each other. These creatures are violent by nature. All they need is the smallest of excuses to unleash their wrath—on you or anyone. If you are able to maneuver them into a crossfire, the monsters' tempers will get the best of them. No room for politeness. They will annihilate each other.

Use Walls and Doors as Shields When you are under fire, find shelter behind a wall or around a bend. You might find that when you lurk behind a wall, the enemy is reluctant to come after you. Then, in peek-a-boo style, sidestep from the wall and take some quick potshots at him.

A similar technique takes advantage of the fact that there are many doors that will open only when you press the spacebar on your keyboard or double-click the walk button on the mouse. If you get into position before opening a door, you can wait there in sniper fashion and greet the monsters crossing the threshold with a load of ammo.

EXPLORING YOUR SURROUNDINGS AND UNCOVERING ITS SECRETS

Besides the hordes of monsters you'll be facing, your biggest challenge in Doom is keeping your wits about you to know where you are and

where you intend to go. As mentioned earlier, Doom's architecture is a veritable 3-D puzzle you must solve. Many keys, aids, artifacts, and weapons lie behind enclosed areas that can only be accessed after you have activated a switch, which itself may lie behind another secret door. In some levels, you will not be able to access the exit if you don't press the right switch or activate a secret door.

In addition, there are sinking or elevating platforms and stairs that may rise out of the floor. In the Shores of Hell and Inferno episodes, you can add teleporters to this list. As you displace yourself in Doom, you always want to take in your surroundings and remember where things are. Make good use of the Automap, which you activate by pressing the Tab key. The Automap replaces your screen with a top view of the portion of the installation you have been to so far. You appear as a small white arrow that points in the direction you are looking.

While you are viewing the Automap, it is a good idea to press the Pause key and magnify different sections for closer inspection. Also, you might consider toggling out of Follow mode (by pressing **F**) so you can move the map around the screen.

It is always a good idea to push any switch you run into. Also, if a wall looks like it might be a secret door, try to open it by walking up to it and pressing the spacebar on your keyboard. But be prepared. It is often the case that aids and weapons are fiercely guarded. Throwing a switch may uncover a good find, but it may also unearth some scary monsters. Take mental notes of things you see. If you run into an area that seems like it could lead to a secret door or passage, mark it on the Automap. After you have thrown a few switches, come back to the suspect area. It could be that one of the switches you just activated caused a bridge to appear, a secret door to give way, or a platform to rise or fall in the area you passed earlier.

TIPS FOR MULTIPLAYER MODE

If you're a user on a local area network, or if you have a modem in your system, you are in a perfect position to experience Doom in its totality. Formidable though they are, the Doom monsters are somewhat lacking

in the gray matter department. To a large degree, you know where you stand with them, and the manner of their assaults may become rather predictable. But when you play alongside (Cooperative) or against (Deathmatch) actual fellow humans, Doom acquires a whole new dimension of excitement and danger.

Via modem or network, you can now deal with more-or-less intelligent beings (more or less like, dare we say, yourself). And it is precisely this intelligence factor that brings into play a whole new slew of strategies and techniques. Besides that, humans can move much faster than any Doom monster. This means that the action quickens as the stakes get higher.

From a psychological perspective, you are also now dealing with frail human egos. MultiPlayer Doom not only gives you a chance to exercise your fighting techniques, it also gives you plenty of opportunities to use cunning, deception, and other useful mind games.

NOTE

Besides strategies, there are other factors to consider in MultiPlayer mode. These relate to additional game controls and other operational considerations. For instance, you can broadcast messages using *Chat*, or use *Spy* to switch your view to another player's. These more basic and technical aspects of the game are covered in Chapter 7.

The following paragraphs discuss general strategy for MultiPlayer's Cooperative and Deathmatch modes. In Cooperative mode, you may team up with up to four people to kick some serious monster heinie back to the infernal gateway it came from. In Deathmatch it's everybody for themselves.

In addition to these two approaches to multiplayer, you can make your own MultiPlayer variations. For instance, you can pair up with a pal and combat another pair of humans. Or you might pit a player with superior skills against two or three others to even the odds. With experience, you'll be able to write your own strategies.

Multiplay in Cooperative Mode

Playing cooperatively involves using many of the same techniques you would use when playing singly. But now, you have someone to watch your back. And, of course, the other person is also counting on you. Here is a handful of strategies you might find useful.

Have a Plan Having a plan is elemental. It can vary between freeform and spontaneous to something a bit more structured. It is up to you and your pals. As with any relationship, the key to success is communicating. Working as a team, you must know what to expect from the others and what they expect from you. You may decide, for instance, to stick together or to separate. You may also consider separating in some installation areas and regrouping in others. You may want to work out in advance what you should do in certain types of situations. Or you can just let your instincts take over. The Chat mode (see Chapter 7) is useful here for broadcasting messages to a particular player or to all players.

The Bait Tactic This tactic is simple. You or your buddies attract the attention of the bad guys while the other person(s) hide nearby. As the monsters' attention is focused on the "bait," the other person can take advantage and hit the monsters from their weak side. This technique is particularly useful if you can make a group of monsters chase you into a vulnerable spot in an open area, where your friend can unload some rockets from a relatively well protected place.

Walking Abreast If you are walking with a buddy, particularly in tight quarters, narrow walkways, and such, the person with the most armor should walk ahead. Also, the person in the back should not fire a rocket without first giving some warning and waiting for the other to move out of the way. In fighting situations, if you are surrounded in an open area, stand back-to-back; if facing a frontal attack, assume protective positions some distance apart, in order to cover a larger angle with your fire.

Multiplay in Deathmatch Mode

The first thing you should know about Deathmatch play is that the best performers are those who've been around a while as single players. That is, the accomplished Deathmatch players usually have paid their dues, playing singly for some length of time. They are skilled at maneuvering and fighting. In addition, a successful Deathmatch player is well acquainted with the Doom episodes and levels. By the time you graduate

to Deathmatch, you should know every nook and cranny of many levels. You should know where to go to get armor, weapons, and ammo. You should also know your weapons and how to use them.

A Deathmatch player has mastered 'most every tip and technique that is explained in this section. Basically, playing Deathmatch involves using what you already know against someone much like you.

Arrange for Your Enemies to Meet In serious Deathmatch playing, the monsters are still fierce and dangerous. But they are not your worst problem; it's the *Homo sapiens* hunting you down with a loaded plasma rifle. In general, when playing Deathmatch, you want to clean out the monsters so you can concentrate on getting to the weapons, the ammo, and all other useful gear. There are occasions, however, when you might want to let a few Demons and Imps loose so they can alert you to the presence of your human foe. Additionally, there may be situations where you might be able to lead your opponent into an area where he is surrounded by monsters and, therefore, easier to pick off.

Grab the Heavy Firepower First Having a bigger, more powerful weapon when confronting an opponent definitely gives you an edge; and it makes you feel better, too. When playing Deathmatch, you will "spawn" in a random location in the level. Regardless of where you land, try to get your hand on the biggest gun you can get. But you don't want to spend *too* much time running for a heavy weapon while armed only with a pistol or a shotgun, so initially you may have to settle for the lighter weapons. That's all right. Bide your time, but at the first good opportunity take the plasma rifle.

And speaking of plasma rifles, since you are dealing with a very fast moving target, you will want to favor those weapons with the faster rates of fire. For this reason, you may prefer the plasma rifle over the BFG 9000. Even though it is clearly less powerful, the plasma rifle's rate of fire lets you sweep over a wider area without having to wait precious seconds between charges. Similarly, a chaingun, although less powerful than a shotgun, covers a larger impact area.

Keep On Playing Those Mind Games Even if you failed Psychology 101, there are numerous opportunities in Deathmatch to “psyche out” the opponent. For example, you can lead your opponent to believe that you entered a room merely by opening a door—but instead of entering, hide. When the opponent runs to get you, jump at him from behind and surprise him with a blinding blast. Sometimes, you can even pretend you were hit. This is one of the oldest tricks in the book. Just lie there and play possum. If your opponent thinks you’ve expired, he might let his guard down for a second. A second is all you need to unload a fatal slug. In this war, everything’s fair. Try to spin your own traps and deploy them. With some practice and perseverance, your cunning might surprise even your most seasoned opponents.

PART TWO

**KICKING
INTERDIMENSIONAL
BUTT**

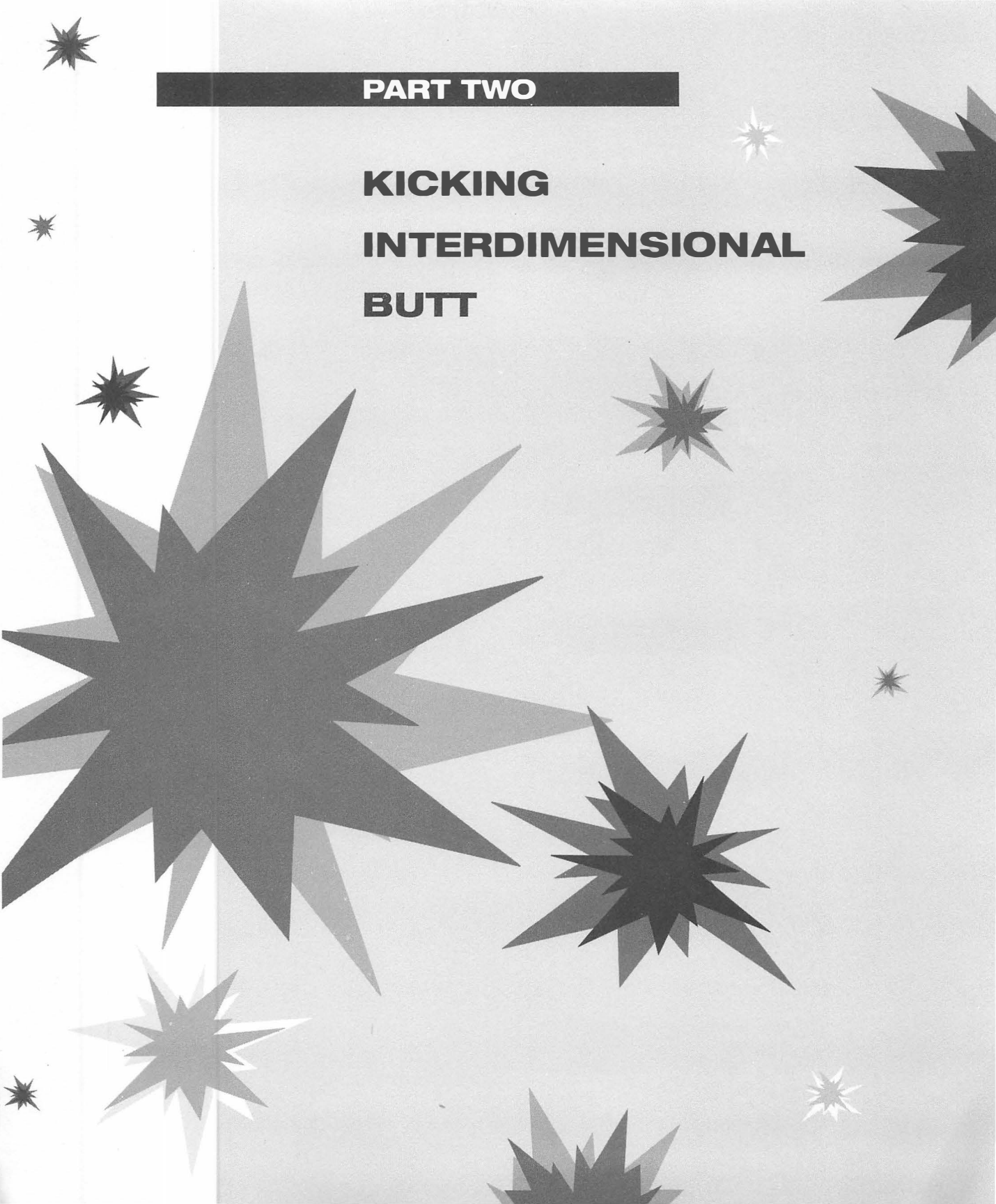

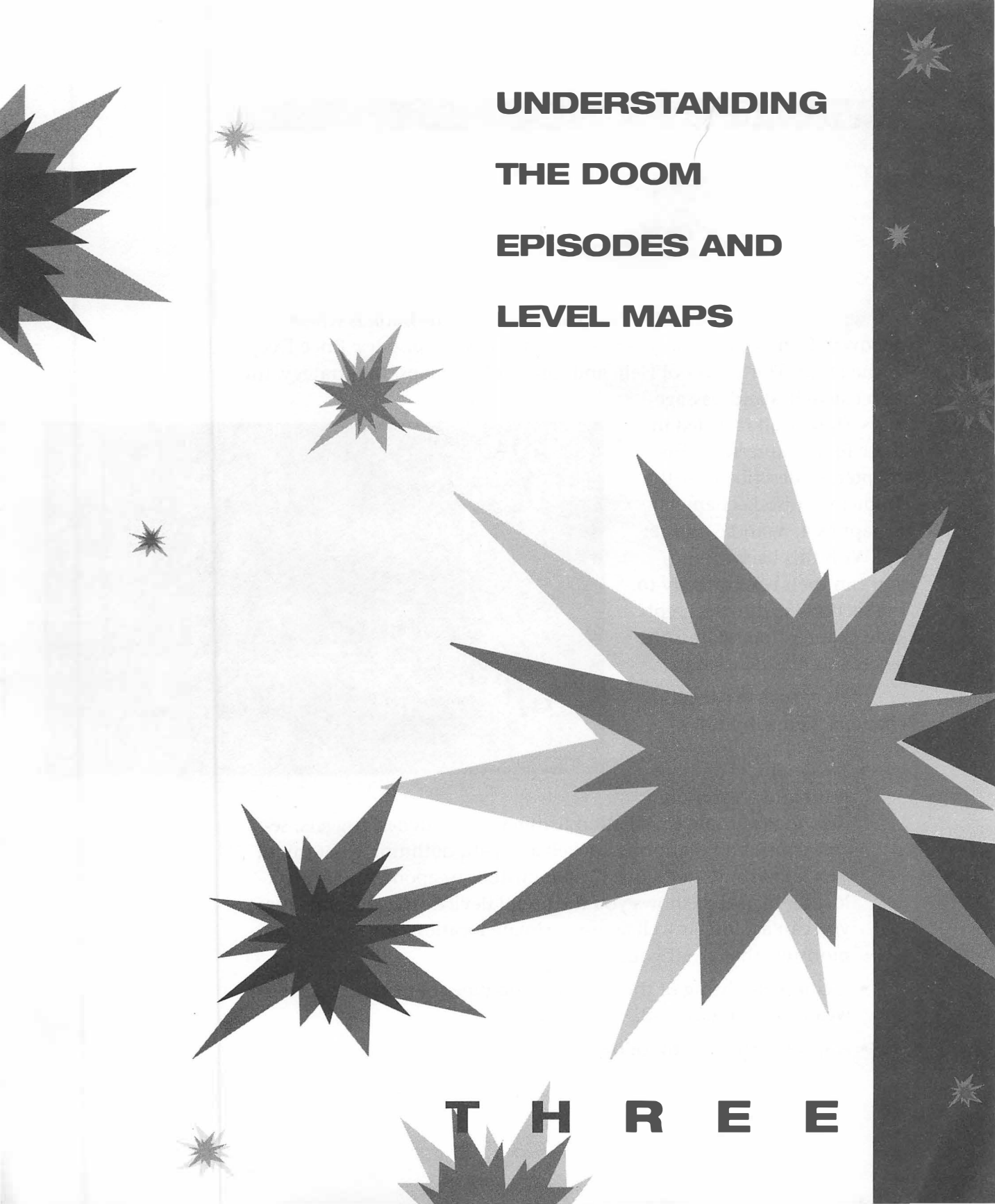

**UNDERSTANDING
THE DOOM
EPISODES AND
LEVEL MAPS**

T H R E E

T H R E E

Organized as a handy reference, this section of the book is where you uncover all there is to know about the three Doom episodes: Knee-Deep in the Dead, The Shores of Hell, and Inferno. The maps, the strategy, the secret switches and passages, they're all revealed in these four chapters. In this chapter we describe how the following episode chapters (Chapters 4, 5, and 6) are set up. With this background, you can then refer directly to the sections within each episode chapter that address the levels you're interested in.

For every level in the episode chapters, you will find:

- Two maps: (1) A blue-print and ideal route map that outlines installation features like switches, triggers, secret doors, and platforms, as well as a path outlining what might be a good route to follow; (2) A monsters, weapons, and artifact locator map that shows you the useful devices and weapons that you can acquire as well as approximate locations for the big bad monsters that await you.
- A complete listing of the numbers and types of secrets and weapons you may find.
- A specific strategy to follow.

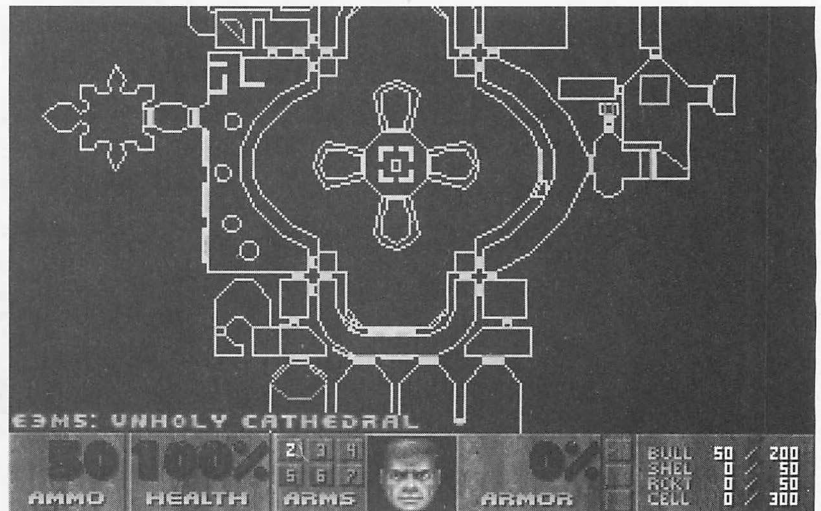

- Useful tips.
- A section on unlocking the level's secrets.

At the end of this chapter, we also discuss how your score is calculated, so you may compare yourself to other players.

THE INSTALLATION MAPS

THE BLUEPRINT AND IDEAL ROUTE MAP

The first map in every level shows a basic blueprint of the installation and recommends a route to follow. This map also highlights particulars about the architecture. This includes switches, secret doors, platforms, triggers, teleporters and other points of potential interest or danger. (To fully understand the relationships between the switches, triggers, secret doors and platforms, read "Interpreting the Blueprint Map" later in this section.)

MONSTER ALERT, WEAPON, AND ARTIFACT LOCATOR MAP

This map shows the initial location of the monsters and their various types. It also highlights the artifacts and weapons you can obtain (computer maps, soul spheres, combat armors, blur artifacts, Medikits, backpacks, etc.). Of course, you should be aware that the map only shows the *initial* location of the monsters. These creatures have free will and they can react to your movements. Even if monsters don't see you directly, they may still hear you fire your weapon or open a door.

INTERPRETING THE BLUEPRINT MAP

Because each level may have any number of switches, triggers, secret doors, and platforms, it is important to note what each switch and trigger does. Generally speaking, a switch or a trigger will cause a platform to rise or lower or a secret door to give way. In this sense you can think of switches

and triggers as activators, and secret doors and platforms as receptors. Some secret doors, however, need no more activation than a push with the spacebar to give way. Likewise, just standing on some platforms will cause the platform to rise or fall. This straightforward relationship is reflected in the way the blueprint maps are coded. The following explanations and examples will help you understand the coding more clearly.

Switches and Triggers Switches and triggers will always cause something to happen, i.e., activating a secret door or a platform. Both switches and triggers are numbered sequentially, in the order that you come upon them while following the paths outlined in the Blueprint And Ideal Route map. For example, you may find the switches and triggers listed as **s1** (switch 1), **t2** (trigger 2), **s3**, **s4**, **t5**, etc. With a few exceptions, no two switches or triggers will ever have the same number in the same level. This makes it very convenient when you link a switch or trigger with its respective secret door or platform. (In the few cases where a switch and a trigger have the same number, it is because they both activate the same secret door or platform.)

Secret Doors and Platforms If a secret door requires nothing more than a push (the spacebar on your keyboard) to open, it is labeled **da** (secret door "a"), **db**, **dc**, and so on. Similarly, platforms that are self-activated are labeled **pa** (platform "a"), **pb**, **pc**, etc.

On the other hand, when a secret door or a platform is activated by a switch or a trigger, the last digit matches the number of the switch or trigger. For instance, if there is a secret door **d1**, you know there is either a switch **s1** or a trigger **t1** that is linked to the secret door. In the same manner, if a secret door is activated by a trigger, its digit will also match the trigger's (as in **t2** and **d2**). The same holds for platforms. A platform labeled **p4** will be connected to the switch or trigger that ends with the number 4. Because the last digits never repeat (they simply continue ascending), there is never any question as to what switch or trigger controls a secret door or platform.

Teleporters Starting in The Shores of Hell, you will also run into *teleporters*, which usually appear as a red platform or a small booth. Entering a teleporter causes you to materialize in a different area of the installation. Teleporters are labeled **T1**, **T2**, etc. In most situations, these work in pairs, so you can expect to see two of each number, making the connection between two teleporters obvious. However, certain special teleporters cause you to materialize in places that may or may not be another teleporter. This type of situation usually occurs when a number of teleporters all send you to the same exact area. In this case, all the teleporters that send you to the same area are labeled with a *letter* after the number—for example, **T1A**, **T2A**, and **T6A** would all send you to a location marked “**A**” on the map, and **T3B** and **T8B** would both send you to a location marked “**B**”.

INTERPRETING THE MONSTERS, WEAPONS, AND ARTIFACTS MAP

The following lists identify the abbreviations used in the monsters, weapons, and artifacts maps. You’ll notice that the monsters are indicated by an upper-and-lowercase combination of letters (**Br** for Baron of Hell, **Cd** for Cacodemon, etc.), the weapons and protective artifacts are indicated by pairs of capital letters (**SG** for shotgun, **BS** for Berserk Pack, etc.), and the cards and keys are indicated by pairs of lowercase letters (**rs** for red skull key, **rc** for red card, etc.).

NOTE

Artifacts and weapons that appear in bold italic on the maps indicate items that are available only when you are playing in Multiplayer mode.

Monsters

Br	Baron of Hell
Cd	Cacodemon
Cyber	Cyberdemon
De	Demon
Fh	Former Human
Fs	Former Human Sergeant

Im	Imp
Ls	Lost Soul
Sp	Specter
Spider	Spider Mastermind

Weapons

BFG	BFG 9000
CG	Chaingun
CS	Chainsaw
PG	Plasma Gun
RL	Rocket Launcher
SG	Shotgun

Artifacts (also referred to as Power-ups)

BP	Backpack
BS	Berserk Pack
CA	Combat Armor
CM	Computer Level Map
IN	Invisibility Blur
IV	Invulnerability
LG	Light Amplification Goggles
RS	Radiation Suit
SA	Security Armor
SS	Soul Sphere
bc	Blue Card
bs	Blue Skull Key
rc	Red Card
rs	Red Skull Key
yc	Yellow Card
ys	Yellow Skull Key

WHAT'S IN A DOOM EPISODE?

As you may have gathered by this point, each of the three Doom episodes is made up of eight different levels plus a special "secret level." A level may be an actual building installation or a geographical location near a base. All of the levels in *Knee-Deep In the Dead* take place in building installations. Most of these buildings, however, have outside courtyards and other large open areas.

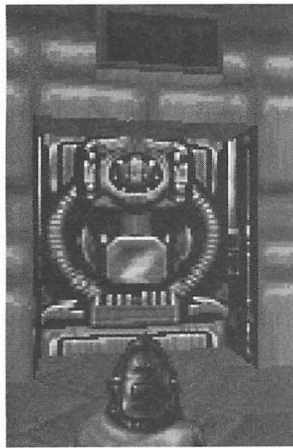

Many of the levels in the *Shores of Hell* and *Inferno* episodes have even larger outside areas or take place almost completely outdoors. But regardless of the episode you are playing, each Doom level presents you with many architectural riddles and seemingly unsolvable situations. And all the while, you must battle fiendish monsters, uncover secret doors and passageways, pick up valuable weapons, grab precious ammunition and other critical supplies, and, above all, make it out alive—and onto the next level.

In other words, getting from point A to point B in Doom can be hell. But you'll be loving it. Eventually, you'll want to reach the door labeled "Exit" in each level. This is the only way to make it to the next level in the sequence without cheating. (For all the information on cheating, see Appendix B: "Cheaters Always Finish First.")

In addition, each level may have a number of doors and latches that require you to have a special color-coded security card or skeleton key in your possession. Keys and cards can be yellow, blue, or red. Oftentimes, you will not be able to leave a level without opening some of these doors. So it is important to keep your eyes peeled for security cards and keys that look something like those in the margin here.



If at all possible, you also want to preserve and build up your health and armor. There are certain maneuvers in Doom that will demand every ounce of strength and protection you have. The more health and armor

you accumulate today, the better your dividends will be tomorrow. In all, there are 27 Doom levels—but any one of them may well be your last. Are you ready for the challenge?

THE SECRET LEVELS

To infuse even more excitement into the game, in each episode there is a level that has a second exit leading into a special “secret level.” These types of exits are very hard to get to. Normally, when you reach an ordinary exit, you continue to the next installation level. However, if you make it to an exit that leads to a secret level, you will have to solve the new level before you can return and continue to ascend levels sequentially from where you left off.

In *Knee-Deep In the Dead*, the exit to the secret level is found in level 3 (the Toxin Refinery), and it leads to the Military Base. In the second episode, *The Shores of Hell*, the exit is in level 5 (Command Center), and it leads to *Fortress of Mystery*. Finally, in *Inferno*, the exit is found in level 6 (Mt. Erebus) and it leads to *Warrens*. Secret levels are especially tough to solve because of their capriciously puzzling architectures. Not to mention their hordes of creepy creatures. To sum it up, you could say that a secret level packs a little extra punch and weirdness. It could be enough to push you over the edge. In fact, just when you think you’ve finally solved the secret level in the third episode, guess again. *Déjà vu* is not unknown in Hell.

YOUR PERFORMANCE

To gauge your performance after you have sweated blood through a Doom level, you can refer to the tally of your successes. There are three basic categories that Doom keeps track of. These are percentages for:

- Your kills
- The useful items you picked up (spiritual armor, health potions, etc.)
- The secrets you uncovered

If your percentages do not read 100% across the board, you know you've missed something.

There is also another parameter you can use to measure your performance on any given level. This is "PAR," the length of time it takes you to ignore everything and just run flat-out for the exit.

Uncovering a secret door, passageway, or switch usually leads to some kind of reward. In some cases the reward might be additional ammo, health, Medikits, light amplification goggles, etc. Other secret doors and passageways lead to crucial weapons, like a rocket launcher, a plasma rifle, and even the coveted BFG 9000. But keep in mind that sometimes the secrets are also tightly guarded by armies of mean monsters.

**KNEE-DEEP IN
THE DEAD**

F O U R

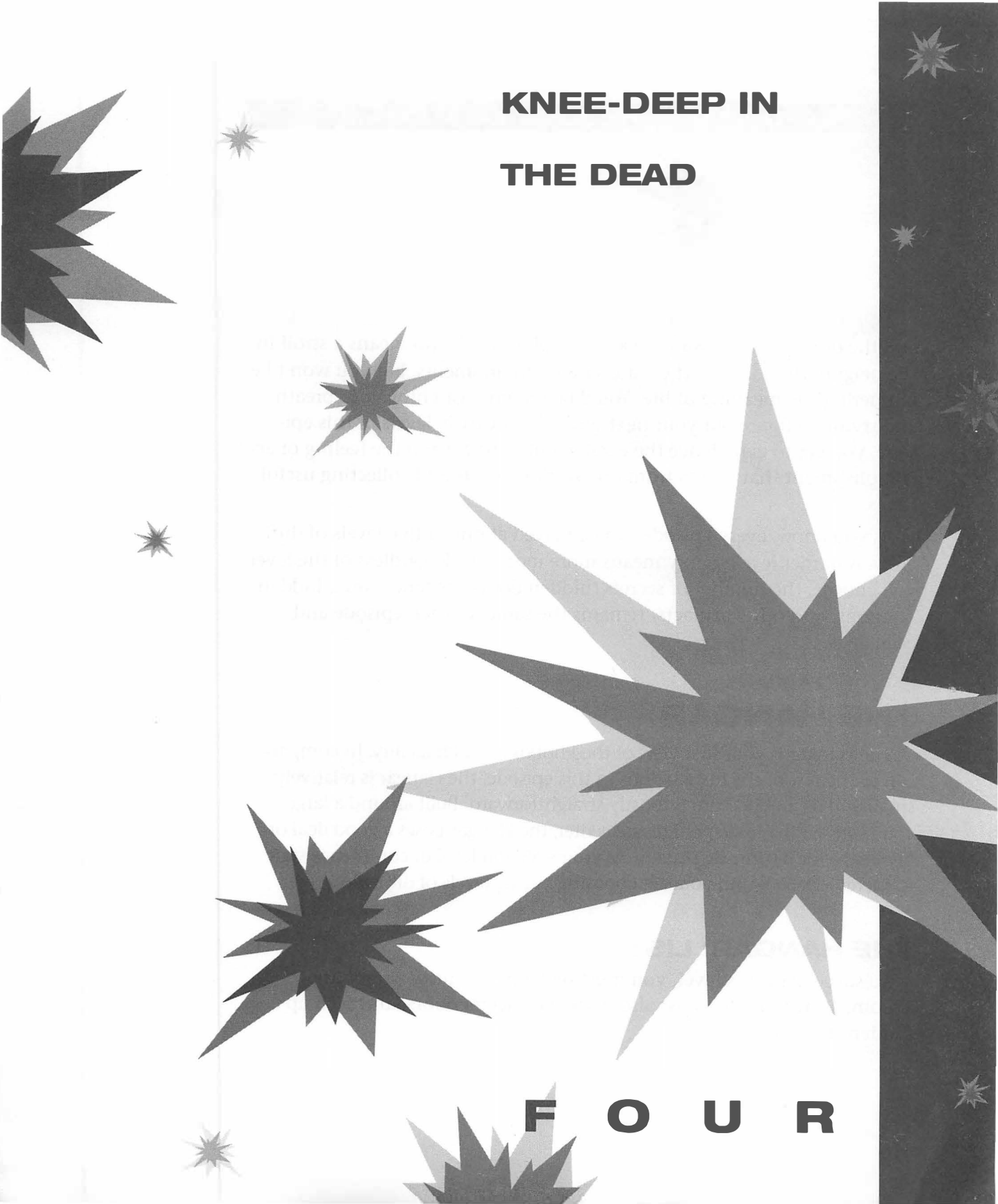

Although Knee-Deep in the Dead is the introductory Doom episode, and the only one shareware users get to play, it is by no means a stroll in the neighborhood. Sure, there are some calm moments, but you won't be pondering the meaning of life. You'll be too busy catching your breath and trying to figure out your next move. In the early levels of this episode, you get to experience the excitement of battle and the feeling of accomplishment that comes from uncovering secrets and collecting useful items.

As you know, every episode can be played at one of five levels of difficulty. A harder level simply means more monsters. Regardless of the level you choose, the number of secrets (hidden doors, switches, keys, hidden weapons, and other artifacts) remains the same for each episode and each level.

THE HANGAR

The Hangar is your first view of the Phobos research facility. In comparison to the rest of the installations in this episode, the Hangar is relatively small and its architecture is mostly straightforward. Built around a large courtyard with a toxic pool in the center, the Hangar poses a good deal of challenge for beginning players. As your skill and level of confidence start to increase, you'll find yourself choosing harder levels of difficulty.

THE HANGAR: LIST

To succeed in this level, you must pick up 1 Security Armor and 1 Combat Armor. You must also discover 3 secret doors, and pick up a hidden shotgun.

E1M1

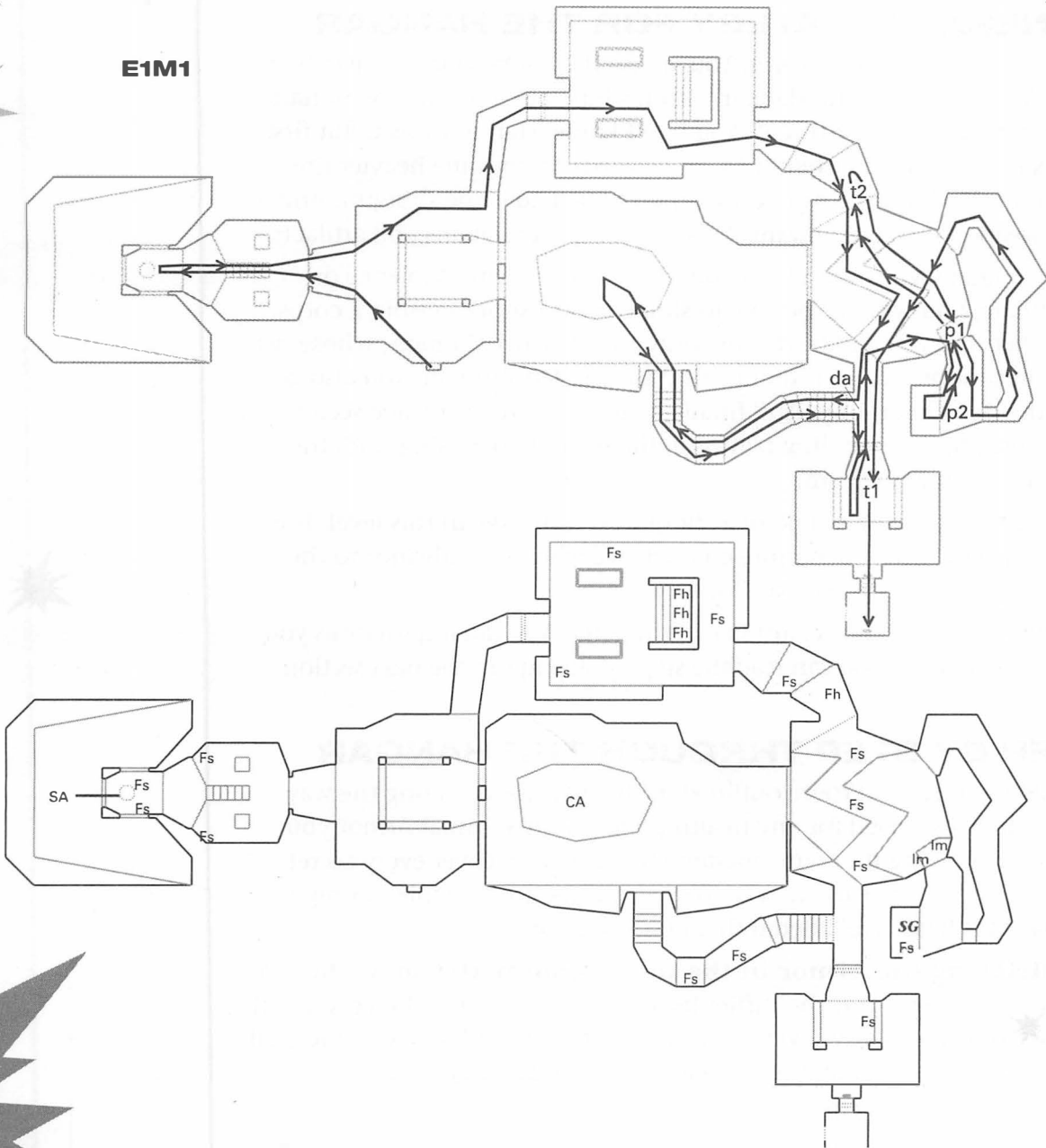

FIGURE 4.1 HANGAR BLUEPRINTS. Top: Ideal route map, indicating triggers and switches. Bottom: Monsters, weapons, and artifacts map.

GENERAL STRATEGY FOR THE HANGAR

This is the moment of truth. You are on the Phobos lunar research facility. You've entered the Hangar with nothing but a pistol in your hand and a big lump in your throat. You don't know what to expect. But first things first. You must attempt to get your hands on some heavier firepower. In this level the heaviest weapon to be had is the shotgun. And a good weapon it is; but you must also look for useful items and artifacts.

If you are playing at any difficulty level besides Ultra Violence or Nightmare, you will not be able to simply take a shotgun from a corpse. That's because you will be dealing only with Former Humans, whose pistols you cannot forage. You must find the hidden shotgun. You also get your first look at an Imp. And finally, you get to uncover three secret doors: one, to a descending platform; the second, to a rising wall; the third, to a rising platform.

Remember, getting a hold of a shotgun is really key in this level. It will just make you that much more competitive when you advance to the next installation, the Nuclear Plant.

Now you have a choice, just like in the game. You can improvise as you go, or if you prefer, you can read the step-by-step tips in the next section.

STEP BY STEP THROUGH THE HANGAR

Follow the general route outlined in the map above. Along the way, keep your eyes peeled for any health potions and Spiritual Armor you can get. Following the route guarantees that you uncover every secret and pick up any useful artifacts. However, there are a couple of tough spots in this level. We'll detail them for you here.

Retrieving the Armor in the small room with stairs: The strategy to use depends on the difficulty level you chose for the episode. If you are playing in any level of difficulty other than Ultra Violence, all you have to do is run up the stairs and grab the Security Armor.

If you are playing Ultra Violence, there will be a total of four guys guarding the armor—two on top of the stairs, and two by the pillars on

each side of the stairs. In this case, your strategy should be as follows. Standing partially shielded by the wall (on either side of the entrance to the small room), begin taking shots at the Former Human Sergeants standing guard below. Even though you may not get a good look at them, they are there. Try shooting at the corner of the pillar to hit the



Former Human Sergeant hiding behind. He will shoot back, so be ready to sidestep out of the line of fire and behind the safety of the wall.

Go to the opposite side of the small entrance and dispose of the other Former Human Sergeant in similar fashion. Then concentrate on taking out the guys at the top of the stairs. If you feel brave enough, rush the stairs as you pump your

handgun. After killing any of these guys, you will be able to grab a shotgun. Shoot the remaining Sergeant and grab the armor. Jump down the stairs and circle each of the pillars flanking the stairs. There are various health potions and Spiritual Armor around each one.

The slime room with the zigzag walkway: The situation in the slime room can be a little trying. There are Former Humans and Former Human Sergeants shooting at you as they try to cross the walkway. At the far end of the room, standing on a platform, is an Imp heaving fireballs in your direction. (If you are playing Ultra Violence, there will be two Imps on the platform.) Your best bet is to stand at a safe distance and try to pick out the grunts on the walkway before they get too close. Dodge the fireballs by sidestepping to either side of the corridor and taking shield behind the walls. After you have managed to kill the Former Humans, move forward to get a better angle on the Imp and shoot repeatedly. Depending on your accuracy, it could take you a half-dozen bullets to bag the Imp.

UNCOVERING THE HANGAR'S SECRETS

The secret door that leads to the Combat Armor: The first secret door, da, leads to a rising wall at the south end of the hall, just past the platform and a few feet before the latch at the end of the hallway. (Consult the Blueprint map.) Walk up to the wall and press the spacebar on your keyboard. The wall will rise. Proceed with caution down the stairs and retrieve the useful items below. If you are playing Ultra Violence, you will have to deal with a couple of Former Human Sergeants, so be ready.

Continuing down the stairs, you will emerge on the open courtyard. Run to the slime pool and retrieve the second armor. Don't take your time about it. Each second in the slime causes your health to drop. Trace your steps back into the building. You will need to push the secret door open when you reach the end of the staircase.

The second security door—lowering the Imp platform: To cause the Imp platform to lower, you must first trip a sensor, t1, inside the southernmost room of the Hangar. Open the latch into the southernmost room with the blinking light. You won't want to rush in. There is an anxious Imp waiting for you. Take some shots at the Imp. If he stands near the slime barrel, try to hit the barrel. As you step inside, you will hear the hydraulic sound of the platform lowering: you have just tripped the trigger. Go back out to the slime room and notice that the platform is on a level with the walkway. Jump across the slime and retrieve the shotgun behind the Imp.

The rising platform behind the Imp platform: Unseen to the naked eye is a small secret door at the southeast corner of the small room behind the Imp platform. To open this door, you must activate trigger t2 at the entrance of the zigzag room. The trigger causes secret door/platform d3 to lower for only a few seconds. You must now run back into the room and stand on the tiny platform. You will be raised to a higher level where you can get a shell box and some additional spiritual armor.

E1M2

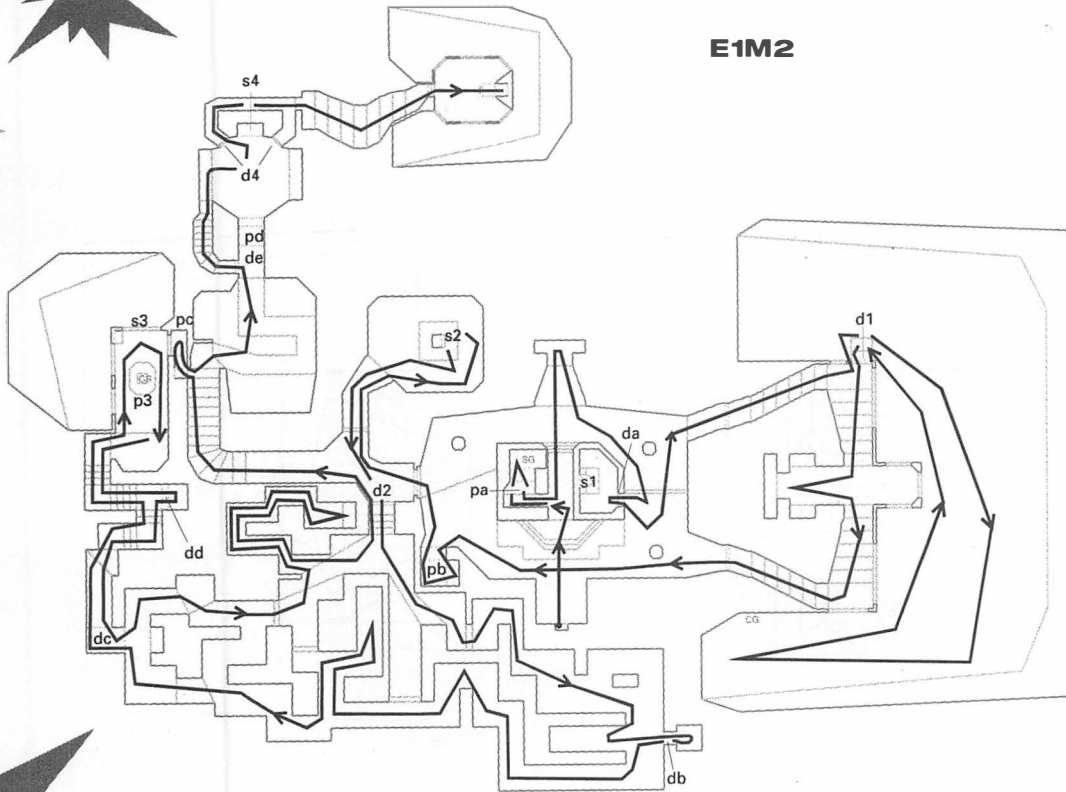

FIGURE 4.2A NUCLEAR PLANT BLUEPRINTS. *Ideal route map, indicating triggers and switches.*

THE NUCLEAR PLANT

In many ways the Nuclear Plant introduces elements and situations that you will see again and again in the higher levels, albeit with many interesting changes and variations. The Nuclear Plant also includes a large outdoor area and a maze-like computer room, elements which you'll encounter often in later levels.

THE NUCLEAR PLANT: LIST

To emerge victorious from the Nuclear Plant, you must discover 9 secret doors and activate 4 switches. In addition, you must pick up 1 chainsaw, 1 hidden shotgun, and 1 chaingun. Finally, you must also grab a

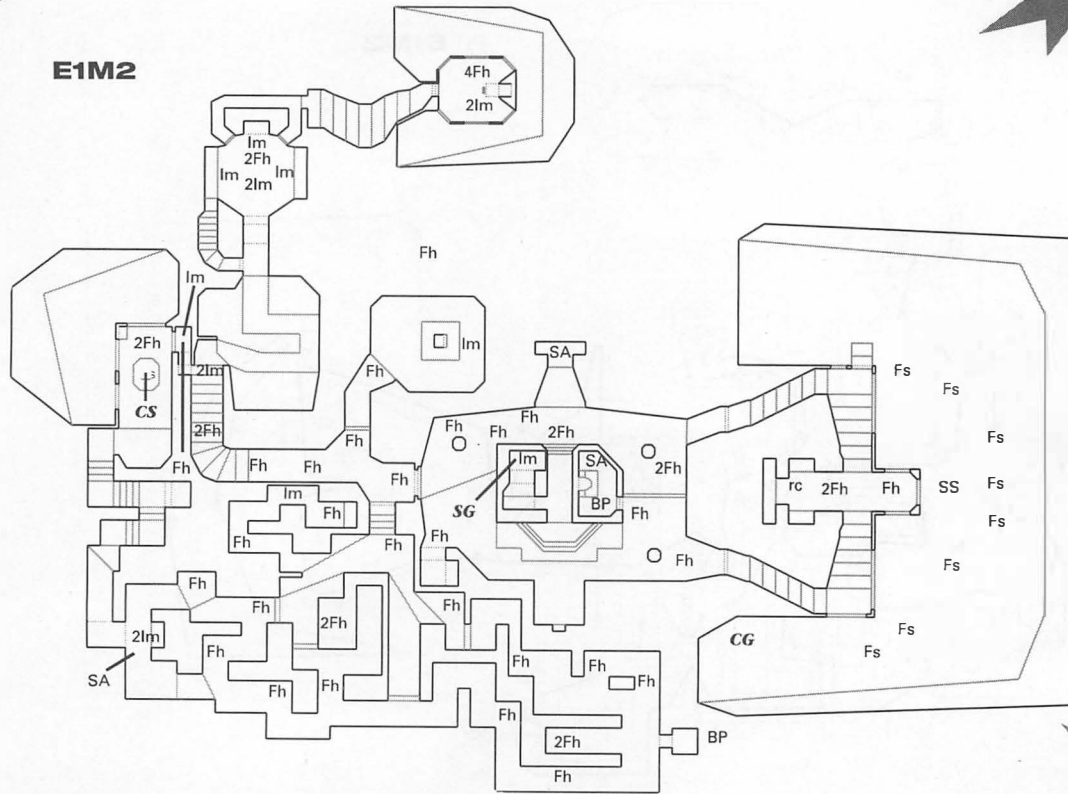

FIGURE 4.2B NUCLEAR PLANT BLUEPRINTS. Monsters, weapons, and artifacts map.

Soul Sphere, a red security card, and a backpack containing your first rocket and a load of 20 plasma cells.

GENERAL STRATEGY FOR THE NUCLEAR PLANT

The Nuclear Plant presents you with many opportunities to experiment with switches, uncover large secret areas, obtain many weapons and artifacts, and see a lot of action. Given these conditions, it is in your best interest to be particularly observant of anything that might seem like a good place to hide a switch, a weapon, or an artifact. Look for walls that give when you push. Ask yourself "What's on the other side of that pillar?" and look for walls that seem discolored or different in texture.

If you entered this level without a shotgun, your strategy will be to secure one right away. You already know there is one hidden that you can access by going up a platform at the south end of the hallway, but you can always rip one off from a dead Former Human Sergeant. Since you also know there is a security card, look for the latch that it will open. (Often a latch requiring a security card is painted in the same color as the card or key.) The computer room, besides being maze-like, is very dark in spots, and the eerie blinking lights only add to your disorientation, so approach every bend with caution. Shoot if there's any doubt.

STEP BY STEP THROUGH THE NUCLEAR PLANT

Even with the route laid out in front of you, it may not be that easy to stick to it. Look at the map and try to pick alternate places to run to in case things get hairy. Look for spots where you might be able to continue inflicting losses while keeping from getting hit excessively. When things settle a bit, you can get back on track.

Surviving the first fifteen seconds: Almost as soon as you enter the Nuclear Plant, you find yourself accosted from every angle. If you only have a handgun, you are in deep trouble. If you have a shotgun from the previous episode, things may not be as dire. Whatever the case, you must take care of the Former Humans approaching directly ahead.

To your right and around the wall, there is also danger. Another Former Human is just waiting for his shot. To make it through this onslaught, your aim and timing have to be nearly impeccable. Notice that there is a barrel just left of the corridor in front of you. Concentrate on the barrel directly ahead. Wait two or three seconds for the Former Humans to get close to the barrel, then fire away. If you manage to connect with your first shotgun shell while the Former Humans are close by, they'll have to be scraped from the cold Nuclear Plant floor.

Turn your attention to your right and shoot a second barrel. That should take care of the Former Human standing next to it. Right about this time, the ensuing explosions will cause everyone within earshot to rush to the area. Now you can either maintain your position and shoot it

out, or move out quickly, take as many monsters down as you can, and find refuge elsewhere. If you have a decent percentage of armor and a good supply of ammo, you can hang back and, strafing to and fro, pick your opponents from the "base line," to borrow a tennis term. The advantage of staying tight and moving just enough to avoid being hit is that your opponents can only come at you from the front.

However, if you like shooting on the run, then go ahead and dash. If you absorb some impacts and your armor level falls below 100%, you need to take the Security Armor directly north or the one behind the secret door on the east side of the hallway.

Obtaining the red security card and the Soul Sphere: If you follow the ideal route for this level, you would normally get the security card after activating switch s1, which opens up secret door d1 to the courtyard area at the far east of the installation. That is a good strategy because you get to take the Soul Sphere, the chaingun, and all the ammo in the courtyard. The chaingun will be a most welcome addition to your arsenal. When you reach the north latch leading to the courtyard, open it and enter cautiously. As you begin climbing the stairs, you will be immediately greeted by Former Humans and an Imp. Shoot the Imp before he gets too close. Look behind you quickly and pick off any Former Human Sergeants that might be making their way into the plant from the courtyard area below. Stick your back to the wall and continue climbing. When you discern a barrel, shoot it. Because the room is quite small, the splash will be enough to kill at least one of the Former Humans at the top. Advance after the barrel explodes and listen for any signs of life. At the top, scan the scene for more enemies. Then rush to get the card and any other goodies in the room.

With the card in your possession, you may either run down into the courtyard or try to shoot a few Former Human Sergeants from the stairs on either side of the room. When you make it outside, you may want to position yourself so the entrance to the plant shields you from the Former Humans. You should also get a good angle so you can pick them off as they rush you. If you take a few shots and your health declines, remember that the Soul Sphere will add 100% to your health level. When the number of enemies is more manageable, venture forth and go for the

sphere. Try shooting any remaining Sergeants on the run. You are faster than any one of them, so make use of your speed.

Pick up the Soul Sphere and continue around the courtyard to the south. There you will find the chaingun and an ammo box.

Disposing of the Imps at the northwest darkened room: You must go through this room to reach this level's exit. Switch s4 on the north wall opens dual latches, one on each side of the switch. Unless those doors are opened, you will not make it out of the Nuclear Plant. The only trouble is that the room houses a few irritable Imps and some ill-tempered Former Human Sergeants. In other words, it's an ambush. But there are two ways you can deal with this situation. First, notice in the blueprint map that just south of the ambush room there is a platform that lowers you into the room. But there is also a secret door that takes you into the leftmost raised area where an Imp awaits. The preferred method is to go for the secret door and take out the first Imp. If you went down the platform,

you would be lowered into the darkened room and the subject of a most hostile reception committee. So opt for the secret door and march slowly down the stairs. As soon as you see the dark area below you, open fire with your chaingun. Because visibility is poor, you'll want to shower the Imp with bullets rather than rely on the single impact of the shotgun. Then, hiding partially at the en-



trance of the narrow walkway, concentrate your efforts on the Imp ahead and to the right. He has the best angle on you and will be heaving fireballs. Finally, sidestep into the walkway as you spray bullets across the room to pick off the third Imp.

If you are facing fire from below, there might be a few Sergeants who refuse to give up. There is no easy way to deal with them. Jump off the

walkway and into the darkened room and sink your finger on the trigger. When you finally get a chance, hit the switch. The doors will open and you are on your way out.

UNCOVERING THE SECRETS OF THE NUCLEAR PLANT

The secrets uncovered in this section follow the sequence in which you would find them if you were to follow the ideal route.

The first platform, pa, is in the main room of the installation, to your immediate left as you enter the hallway in the center of the room. When you step on it, it raises you to a small compartment where you'll find a shotgun and four shells.

The first secret door, da, leads to a small room that houses a Security Armor, a backpack, a Medikit, a Spiritual Armor, and switch s1. (s1 lowers door d1, which gives you access to the courtyard on the east side of the installation).

The next platform, pb, is found at the southeast corner of the main room. This platform too is sensor-activated. Normally this platform remains raised. However, when you get near it, the platform lowers. Access it and ride it up to a compartment with a Medikit and a box of ammo.

The next secret door, d2, opens the only entrance to the computer room. To open d2, you must first activate s2, which is found on the pillar of the toxic sludge room. This switch is not immediately visible from the entrance because it is on the east face of the pillar.

The next set of secret doors are found inside the computer room. Secret door db is found at the southeast end of the room. This door is flanked by two bright metal strips. Inside this small room, you will find a backpack.

Secret door dc is at the opposite side of the computer room. To access this door, you must take a few shots at the "impact wall" behind the Security Armor. If you enter the corridor, you will run into a Medikit and eventually into dd, the next secret door. Push the door open and you will find four Spiritual Armors.

The next switch in this level, s3, is found in the small room where the chainsaw is kept atop a platform. When you activate the switch the chainsaw platform is lowered. Then you can grab this crude but very effective weapon.

The next platform, pc, is very small. It is a recessed area to your left, on the last step, as you get ready to enter the sludge room. When you get on pc, you are lowered to a small room that looks out into the chainsaw room. In this tiny room there will be an Imp and a Former Human waiting to prey on anything that moves. (There is also a Medikit down there.)

The next secret door along the route, de, is found to your left immediately after you've crossed the sludge room. This door leads to the darkened room where an Imp is perched on one of the raised narrow walkways that flank the darkened room.

The next two secret doors are both labeled d4 because they operate as one. These doors are inside the darkened room to the left and right side of switch s4. You must activate that switch to open both d4 doors.

Finally, the fourth platform, pd, is located just north of de. When you step on pd you are lowered into the darkened room, where a host of Imps and Former Human Sergeants lies in wait. You should only take this route if you feel particularly daring.

THE TOXIN REFINERY

When you first arrive in the Toxin Refinery, you might be surprised at the apparent calmness of it all. You almost wish you could stay longer in this island of tranquility. Of course, the intensity level soon picks up several notches. If you are playing in Ultra Violence mode, you get to see your first Specter in the flesh (sort of) and also your first Demon.

Not only is the action more fast and furious in this level, the installation itself presents several new challenges and puzzles. There is an abundance of switches, secret doors, platforms, and triggers. Like switches, triggers cause physical changes in the architecture. Unlike switches, they do not have to be turned on deliberately. A trigger relies solely on a motion-sensitive mechanism that you activate whenever you cross a specific point in the installation.

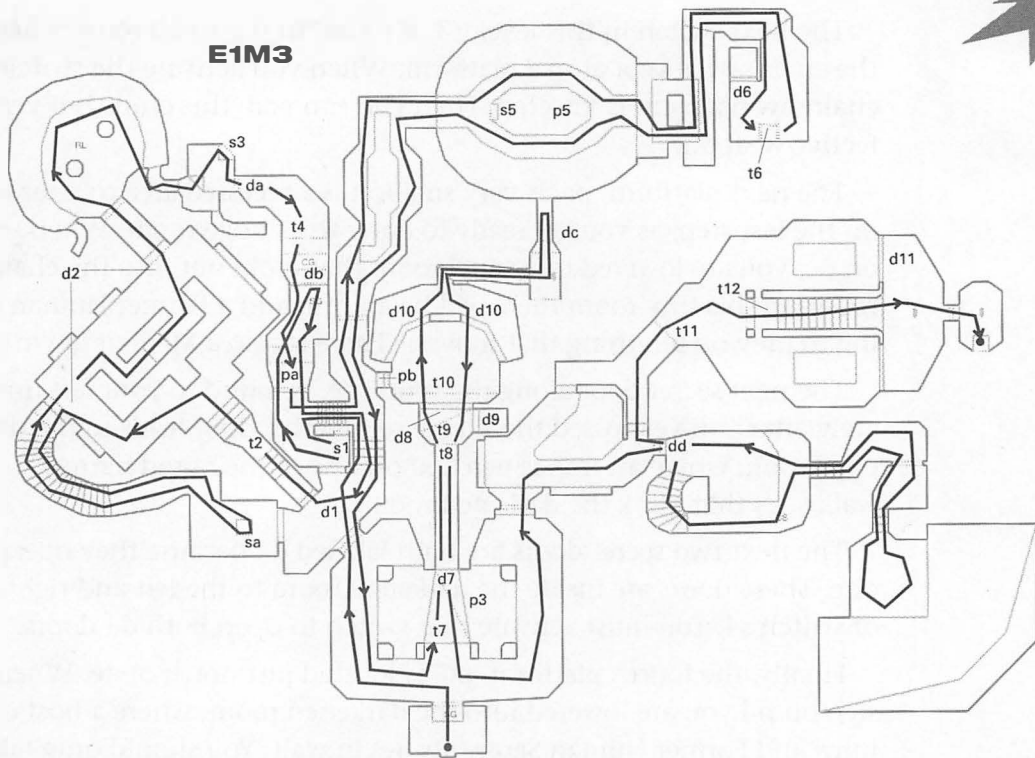

FIGURE 4.3A TOXIN REFINERY BLUEPRINTS. *Ideal route map, indicating triggers and switches.*

Commensurate with the number of switches, secret doors, and triggers, the Toxin Refinery has a wealth of hidden weapons, ammunition, and useful artifacts. In this level you get your first rocket launcher. But perhaps most significant of all, the Toxin Refinery contains the exit that leads you to the secret level of this episode.

TOXIN REFINERY: LIST

You can leave the Toxin Refinery from one of 2 exits. Regardless of the exit you decide to use, you can still get all of the secrets. The normal exit takes you to the next level, Command Control. The second exit leads to the secret level for this episode, the Military Base. In this level there are 4 switches, 11 triggers, 9 secret doors, 1 secret door/switch combination, and 4 platforms. The hidden weapons include 1 rocket launcher,



FIGURE 4.3B TOXIN REFINERY BLUEPRINTS. Monsters, weapons, and artifacts map.

1 chaingun, and 1 shotgun. Along with these weapons there are also a backpack and a few boxes of ammunition (rocket cases, etc.). The artifacts for this level include 1 yellow security card, 1 blue security card, 2 Soul Spheres, 1 Blur artifact, 2 Security Armors, and 1 Combat Armor.

GENERAL STRATEGY FOR THE TOXIN REFINERY

In this episode there is a balance of calmness and complete mayhem. On the one hand, you must have the presence of mind to stay cool and alert even when everything seems quiet. On the other hand, you must fight with the intensity of a tiger and the intelligence you clearly have over the monsters. Here is your chance to put it all together—the techniques, the moves, the strategy. The two monsters introduced in this level, the Specter and the Demon, are both capable of charging and

devouring you alive. The best way to fend off these hungry fellows is to put the chaingun between you and them. If your aim is really good, you can opt for the shotgun. But it might take you two square shots at mid-distance to give each one his final supper. Of course, if either chap gets too close, it's time for a little chainsaw action.

Because this level also makes extensive use of switches and triggers, you must remain focused and notice any changes after activating a switch. With triggers, you must learn to rely on your ears. Because triggers give no sign of their presence, try to listen for the hydraulic sounds of platforms raising or lowering. After you've secured the rocket launcher, don't forget to use it. There will be moments when you'll be surrounded by hordes of nasty monsters. Study the installation maps and then see how you measure up.

STEP BY STEP THROUGH THE TOXIN REFINERY

The ideal route takes you on a path to uncover every secret door and collect all useful artifacts and weapons. The path also assumes that you will be going on to the next level in the sequence, Command Control. However you may desire to take the secret exit instead and pay a visit to the secret level, the Military Base. If this is the case, you will need to adjust your route. In your revised route, you should still plan to scout the area around the normal exit, for there are several weapons and useful artifacts there to be had.

Surviving the initial onslaught: You start this level in a small enclosed room. Pay no attention to the stiff, and collect the few shells and bullets lying around. The second you open the latch, especially if you are playing at the harder levels of difficulty, you'll be walking into a very cruel surprise party. In Ultra Violence, besides the monsters you're already familiar with, there will be two new additions, the Specter and the Demon. Both love to charge. Both love to eat.

As in other ambush situations, your basic options are to hold your ground or to dash and get some wider space to maneuver. Of course, you can combine these strategies. Hold your ground for a few seconds and take out a few monsters, then dash for it and get more breathing room. If

you hold your ground, stick to the side of the latch where you are not a wide-open target. Reach for the chaingun. It is recommended over the shotgun because it will give you a wider spread and a constant stream of bullets. Then open the door and let your chaingun do your talking. If an Imp or Specter rushes you, switch to the chainsaw. These monsters have no projectiles to shoot; all they can do is rush you. Keep them at arm's length with the chainsaw and rip right through them.

If and when you decide to rush, be careful not to fall into the toxic pool in the middle of the room. (If you fall in, you're as good as dead.) Run to either side of the pool. If you go right, you won't be able to open the latch at the end of the room, because it requires a blue security card. So don't waste time trying to open this door. If you go left, you can open the latch. But there are more monsters behind that door.

Another very useful strategy is to cause dissension among the monsters. Sometimes the best thing to do is to do nothing at all. If you open the latch and keep completely mum, the monsters might turn on each other. This will save your energy and ammo. If you manage to dispose of all the monsters, then, when you reach the latch on the northwest corner, employ a similar strategy. The latch opens into a room with a barrel in the center. Shoot the barrel at your first opportunity. Then hang on the side and clean up the remaining monsters as soon as each one starts to cross the threshold.

Reaching the secret doors in the computer area: The computer area, at the far northwest extreme of the Toxin Refinery, has two secret doors. It also hides the yellow security card (which you will need later to open the room at the southeast corner of the installation, where a Blur artifact and a Soul Sphere await you). The computer area lies behind secret door d1. To open this area, you must first activate switch s1 inside the small room just north from the latch leading to the left wing of the structure.

There are two secret doors d2 and they are both activated by trigger t2 halfway up the stairs leading to the computer room. Both of the doors lead to some very useful artifacts and weapons. Secret door d2, the southernmost door in the computer room, houses a Soul Sphere. The other d2 door leads you to a rocket launcher and rocket case, besides other artifacts.

These doors are very difficult to reach because they only remain open a few seconds. Also, because the room is guarded by a few unfriendly monsters, you must clean out the room before you can rush the stairs unhindered.

Reaching these doors, then, is a three-step process. First, you must activate switch s1. Secondly, you must clean up the room of any monsters. Finally, you must activate the trigger that opens the doors, and rush to the first door before it closes. (When you emerge from one of the doors, the other door also opens.)

After activating switch s1, secret door d1 opens to reveal ascending stairs into the computer area. Now your job consists of cleaning the room of any monsters. Standing at the bottom of the stairs, use either the shotgun or the machine gun to make ribbons of the Former Humans Sergeants that are sure to come rushing down. After that you still have a Specter and a Demon to contend with. Your weapon of choice: the chainsaw. Rush the stairs and get the job done. (Listen for the sound of doors opening as you trip the sensor halfway up the stairs.) If you like, grab the yellow key at this point once the monsters are put away.

Finally, to make it to either of the secret doors, go back downstairs and decide which way you intend to go. (Both secret doors are equally distant from the stairs. They are both located on the wall on the far side of the computer room.) Take a running start and don't stop running until you make it to the secret door you've chosen. (It is recommended that you first visit the secret door to your left as you enter the computer room, because the other door will eventually lead you to yet another secret door, which in turn leads you to additional weapons and supplies.) The door will raise when you stand on it, but it only goes up halfway.

Go below. You will go down a dark circular staircase. Because the visibility will be very limited, open fire as you move down. You can't afford to be surprised by the Imps guarding the Soul Sphere. The other secret door (at the far north side of the room) is only accessible as you trip the trigger near the southernmost secret door when you are ready to emerge with your newly acquired Soul Sphere. You must race to it from the first secret door. Here you will find a circular floor surrounded by green slime. Again, open fire as you go below. Grab the rocket launcher, the rocket case, and any other items you can use. (The ooze encircling the room

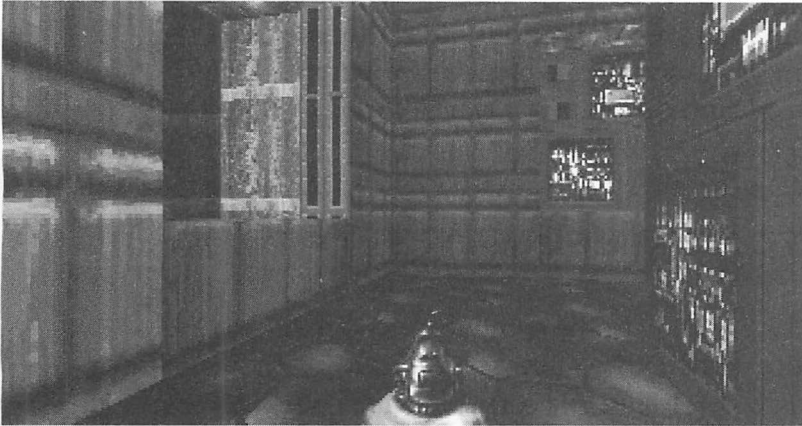

leads to a small platform where switch s3 is found. In addition, a few steps from this switch lies secret door da. Switch s3 activates p3, the platform that rises from the ooze in the initial room, and which leads to a central area where more artifacts are to be found. This is also where you'll find the door leading to the secret level. (To find

out more about this, read "Uncovering the Toxin Refinery's Secrets.")

Dealing with the hordes of Imps in the central room: The only way to make it into the central room is by activating switch s3. This switch, in turn, is only accessible by following the ooze that surrounds the circular room behind the north secret door in the computer room. Assuming you have activated that switch, when you reach the initial room you will see a long walkway stretching across and over the ooze into the central area. As you begin to cross the walkway, you will trip a sensor that opens up a door at the north end of the walkway.

Approach the entrance slowly. There are two additional triggers in close proximity to each other and both very near the entrance threshold. The first trigger opens a small room to your immediate right, where a couple of monsters are kept. Deal with these monsters first (the chain-gun is recommended) and grab the goodies. The door to this room will remain open, and it's a good thing, because you may have to retreat to here for protection.

As you emerge from the small room, switch to the rocket launcher. The instant you trip the second trigger, the much-talked-about horde of Imps will be set free from its confines at the back of the room. This is a good time to pedal backwards into the walkway and release a couple of rockets. Be careful not to fall into the ooze once you clear the walled area of the walkway. If you need to, unload the remainder of your rockets,

but make each one count. Of course, to save this precious projectile, you can always switch to the chaingun or the shotgun, whichever you prefer. Clean up the rest of the Imps and advance to discover the area's many artifacts.

UNCOVERING THE TOXIN REFINERY'S SECRETS

Switch s1 uncovers the secret door leading to the computer area on the northeast side of the installation (where the yellow security card is found). Inside the same room where s1 is found, platform pa, where a Security Armor vest is resting, takes you up into an area containing a Medikit, a shotgun, and some ammo.

Secret doors d2 (two of them) are activated by trigger t2, which is found halfway up the stairs to the computer room. Behind the secret door to the left of the staircase, you will find a column with switch sa, which lowers the platform where the first Soul Sphere rests so you can take it. The other d2 secret door, at the north end of the room, leads to your first rocket launcher, a case of rockets, a Security Armor, and a few other smaller items.

The next switch, s3, is found just east of the circular room surrounded by ooze. To access it, you have to run in the ooze for a few seconds. Next to the switch you will find a backpack. This switch activates p3, a long platform that bridges the ooze in the initial room and gives you access to the central area. Another important discovery in this immediate area is secret door da, which leads to a hidden chaingun, an ammo box, and a couple of Medikits. The Medikits are sitting on a platform, which lowers as you set off trigger t4. When you stand over the platform, it will rise again. This makes secret door db, a one-way secret door, accessible. Push this secret door to uncover a few more useful items.

The next platform en route is pb. This is a small indented area that causes the upper part of the wall to lower, letting you peek and take shots at the Former Human Sergeants swarming below (in the central area).

Switch s5 is found in the oval-shaped area in the north extreme of the installation. This switch is only accessible if you jump into the ooze pit. (You can actually avoid the ooze by landing directly on the small platform

where the switch is accessible.) This switch causes platform p5 to rise from the bottom of the pit, giving you a Medikit for your efforts.

The blue security card is located on the northeast corner of the Toxin Refinery. The key is surrounded by a perimeter trigger, t6. When you trip the trigger, secret door d6, located north of the card's location, rises, releasing a few mad Imps.

Trigger t7 cuts a diagonal line across the walkway leading to the central room. This trigger raises secret door d7 and lets you enter the central area of the Refinery.

At the very threshold of the central area, trigger t8 opens secret door d8, a second latch to the central area. A few more steps into the threshold, trigger t9 opens secret door d9 to the immediate right, thus releasing a couple of bad guys. A couple of more steps into the area causes trigger t10 to raise the dual secret doors d10, releasing several Imps into the open area.

Secret door dc is the north wall of the room where the exit leading to the secret level is found. Push it and then stand on the platform. You will be raised to a narrow passage where you can get a case of rockets. This same passage overlooks the oval area at the north end of the Refinery.

Combination secret door/switch dd makes accessible the entire southeast corner of the Refinery. In the southernmost corner of this area you will find a Combat Armor, the Blur artifact, and a Soul Sphere.

Trigger t11, located in the diagonal corridor en route to the normal exit for the level, opens door dd.

Finally, trigger t12, located at the bottom of the stairs leading to the exit, produces the stairs you must climb to exit.

COMMAND CONTROL

Somber, heavy, and unadorned, the architecture of Command Control sacrifices not an ounce of function to form. This installation is most definitely inspired by the heavy military garrisons that rose like mushrooms in the European landscape during World War II. Nowhere in Doom is the

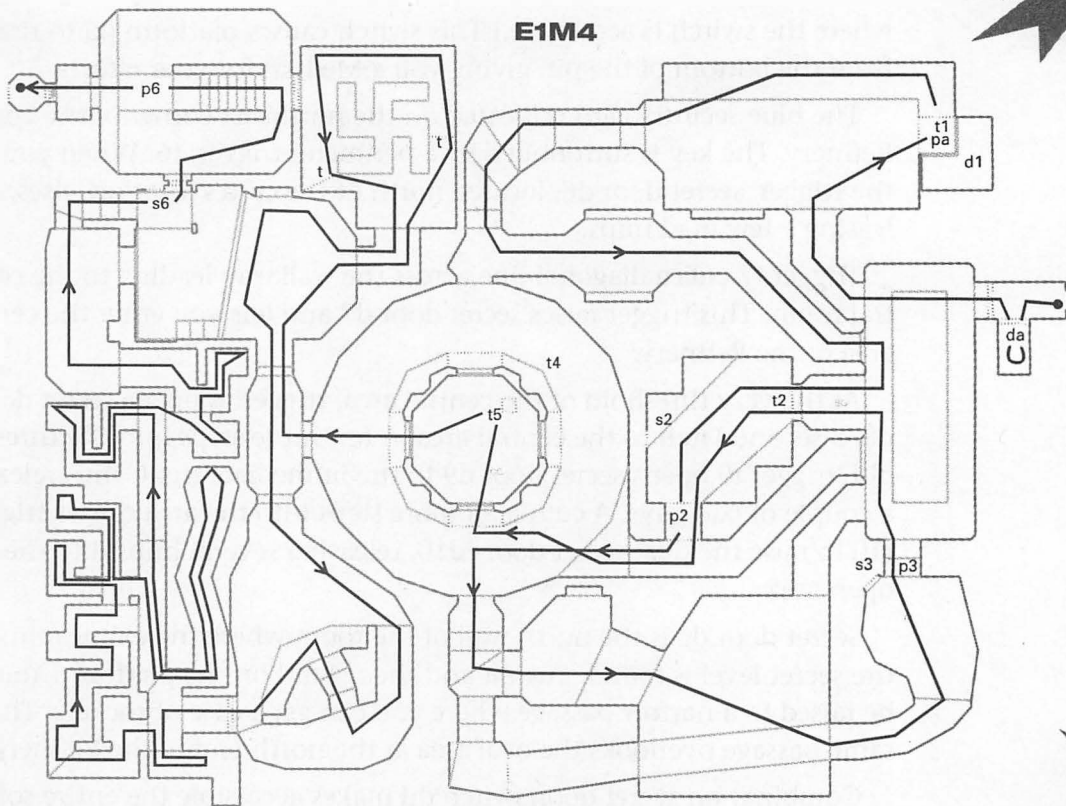

FIGURE 4.4A *COMMAND CONTROL BLUEPRINTS. Ideal route map, indicating triggers and switches.*

World War theme more evident than in the computer room at the north-west corner of the installation.

Command Control's fortified high walls, long corridors, and wide-open areas provide the backdrop for the action. And action is what characterizes this level more than anything. With a minimum of switches and secret doors, this level forces you to rely heavily on your fighting skills and to take them to a higher plane.

COMMAND CONTROL: LIST

In this level there are only 4 switches, 3 secret doors, 5 triggers, and 6 platforms. The useful artifacts include 1 backpack, 1 Combat Armor, 1 Security Armor, 1 radiation suit (2 if you are playing in the first two

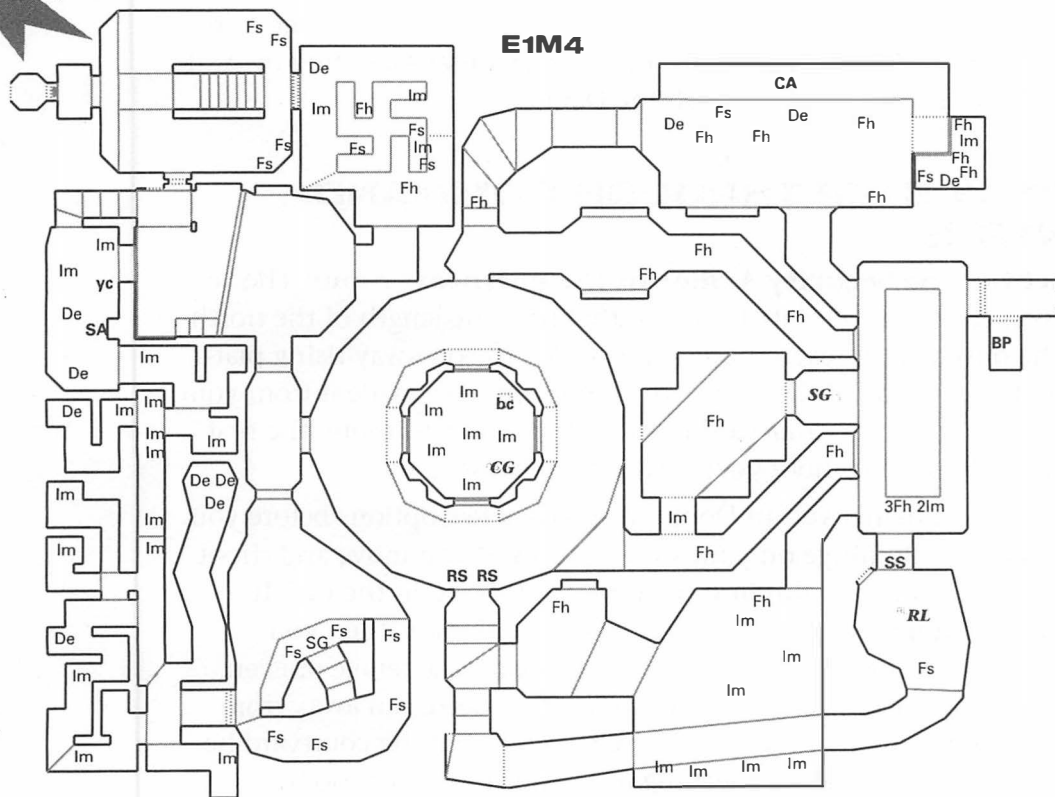

FIGURE 4.4B *COMMAND CONTROL BLUEPRINTS. Monsters, weapons, and artifacts map.*

difficulty levels), 1 blue security card, 1 yellow security card, and 1 Soul Sphere. The hidden weapons include a rocket launcher and a chaingun.

GENERAL STRATEGY FOR COMMAND CONTROL

Because fighting is the rule rather than the exception in this level, your strategy should be to make short work of your adversaries and amass as much ammo and as many weapons as you can possibly carry. You'll also do well to run fast across open areas, where you are most vulnerable. When you move down the larger corridors, use caution and be ready to fire at the slightest sign of danger. When you enter the narrow convolutions of the southwest area, you should make good use of the

chaingun. With monsters closing in on you, there isn't much time to reload your shotgun. Also in this area, have the chainsaw standing by. You will need it to rip your way through the Demons.

STEP BY STEP THROUGH COMMAND CONTROL

Reaching the Security Armor in the northeast room: The Security vest sits on the elevated corridor that runs the length of the north wall. The only way to reach that level is to ride the one-way rising platform on the east side of the room. Assuming you have made it from your starting spot across the courtyard to the entrance of this room, the first order of business is to shoot your way to the platform.

As with most maneuvers in Doom, you have a few options before you. Your choice should hinge on your strong points. If you move and shoot well, you might want to run into the room and shoot on the run. If you're most composed when remaining fairly stationary, then you should pick your shots from a spot where you can take refuge or even run away from danger. To ensure that you can, indeed, run away from danger if you need to, you're best advised to clean out the courtyard before you run into the corridor leading to the northernmost room.

The second you push open the latch to the east courtyard, you will be the target of Former Humans positioned high on the facing wall. There will also be a rush of monsters coming at you from the south end. You might try a few shotgun blasts against the Former Humans sitting high. Fortunately for you, each cubbyhole has a sludge barrel you can aim for. To deal with the monsters below, your best bet is the chaingun. The large concentration of monsters forms a gruesome moving wall. Spray it full of bullets and avoid the Imp's fireballs.

When things subside in the courtyard, enter the northernmost corridor. Then decide whether you will run in and shoot it out or stay put and pick your targets. If you've cleaned out the courtyard, remember that you can always run back there if the heat gets too intense. The enemy is widely scattered in this room, so take a few shots and then move around to pick off other targets. If you decide not to rush the room, you

will still have to stay very light on your feet, sidestepping to avoid the dreaded fireballs. If you have a chainsaw from the previous episode, keep it within reach at all times, especially if a Demon gets too close. When

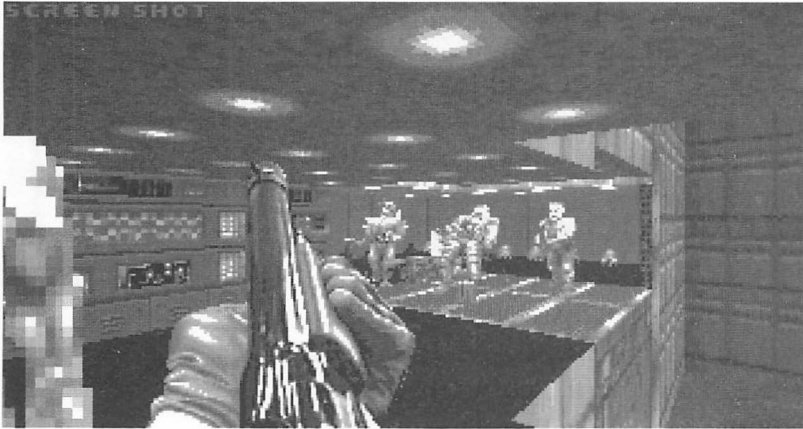

you make it to the platform, it will rise the moment you set foot on it. If you haven't killed the Former Humans on the raised corridor, do it before you get off the platform. A trigger on the north side of the platform will open an L-shape secret door, releasing a good number of monsters, so before you dare to step off the platform, turn to face south-east. As you take your first

step going backwards, the secret door will rise. Sink your finger on the chaingun trigger, or if you have a rocket to spare, this will be a good time to release it. Clean up any monsters that survive the blast and then head for the Security Armor.

Collecting the Soul Sphere at the south end of the east courtyard: To get to the south side of the installation where the Soul Sphere sits, you must wade through a narrow channel of toxic ooze. Avoid sapping your health to dangerous levels by wearing the radiation suit (which is found at the entrance of the hallway leading to the southeast area). When you reach the Soul Sphere room, you will notice a lowered platform and a wall switch next to it. You will only get one chance to activate the platform, which begins to rise as soon as you press the switch. You may want to save your game right before attempting the maneuver. Carefully position yourself so you're able to push the switch and immediately run toward the platform. The angle between the switch and the platform makes this somewhat difficult. You will have to sidestep and then run forward very quickly. If at first you don't succeed, reload the game and try again.

Surviving the Imp and Demon attacks in the southwest

maze: Your chances of surviving the maze and the Imp and Demon onslaughts in the maze will be significantly increased by your ability to change weapons on the move. If you like the chaingun and the chainsaw, this is the time to make these weapons shine. Use the walls for shields. There are plenty of them. Sidestepping is the safest way to turn the ninety-degree corners. Fire on any monster that shows its face. Save the chainsaw for tighter quarters.

UNCOVERING COMMAND CONTROL'S SECRETS

The first secret door in the Command Control installation, da, is found inside the small room where you first enter this level. It is on the south wall just before the exit to the east courtyard. Behind this secret door you will find a backpack, an ammo box, and a Medikit.

Platform pa is found at the east side of the north room. When you step on the platform, it rises automatically. As you step off the platform, you set off trigger t1, which causes the L-shape secret door d1 to lift, unleashing a barrage of monsters. Behind d1 you will find several health potions and Spiritual Armors.

The Combat Armor is found on the raised corridor stretching east to west in the north platform. The next trigger, t2, is found at the entrance of the room between the north and south rooms, just east of the central area of the installation. This trigger lowers platform p2. In the very same room, there is also a switch that lowers the same platform. This switch, s2, is found on the west wall, just left of the computer consoles at the edge of the raised area.

The radiation suit is found next along the route. It is located directly south of the central kiosk. The next switch, s3, is found at the southeast room of the installation. This switch causes platform p3 to raise so you can grab the Soul Sphere sitting high upon the wall.

Trigger t4 completely surrounds the center kiosk. Whenever you get near any of the kiosk doors, the trigger causes all doors to rise as one. In the harder levels, various Imps will lash out at you. Inside the kiosk you

will find a blue security card and a chaingun. The blue security card is surrounded by another perimeter trigger, t5. This trigger causes all the kiosk doors to open.

The next two triggers are found in the computer room with the inverted swastika. Either of these triggers will cause the swastika to lower, revealing two rocket cases and one Medikit. The yellow security card is found north of the maze at the northwest corner of the installation. The final switch in this level is found along the north wall of the room leading to the level's exit. This switch causes a platform to rise and bridge the gap that allows you to reach the exit.

PHOBOS LAB

The Phobos Lab dispenses a dose of challenges and obstacles. This level offers a good mixture of action and presents you with a wide variety of secrets to uncover. There is ooze everywhere. (You won't be able to leave the Lab without taking a few dunks). There are also some dark passages and corridors in the Phobos Lab. If you can endure these elements, you will be able to pick up some key artifacts and weapons. Although simple in design, the Phobos Lab can keep you guessing for a while. Its innovative use of ascending pillars adds a new dimension to the level. And just when you think you've cleared every hurdle and fought every battle, you will find that the exit is nearly impossible to find due to almost complete darkness. Thank God light amplification goggles were invented. Now, if you could only find them.

PHOBOS LAB: LIST

The Phobos Lab houses 4 secret switches, 6 triggers, 3 secret platforms, and 9 secret doors. The useful artifacts include: 1 Soul Sphere, 1 yellow security card, 1 blue security card, 2 Combat Armors, 1 Security Armor, 1 radiation suit, 1 computer map, and 1 pair of light amplification goggles. The hidden weapons and ammo include: 1 shotgun, 1 rocket launcher, 1 rocket case, 1 chainsaw, 1 chaingun, and 1 backpack. At the north end of the Lab, you can also find various rockets scattered about.

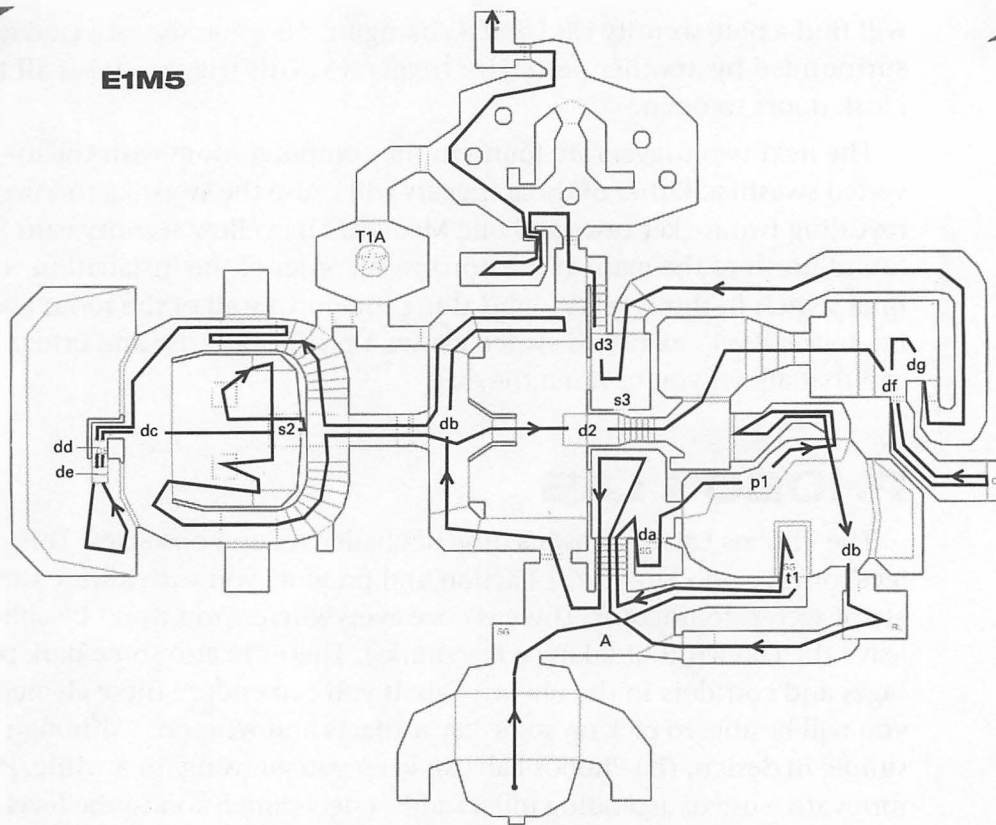

FIGURE 4.5A *PHOBOS LAB BLUEPRINTS. Ideal route map, indicating triggers and switches.*

GENERAL STRATEGY FOR PHOBOS LAB

In this level, you must not be afraid of taking a few plunges in the ooze. Sometimes this is the only way to get to where you need to go. If your health begins to decline, take every health potion you can possibly swallow and keep an eye open for Spiritual Armors—not to mention the Stimpacks and Medikits. They are your key to staying alive. Remember to target barrels when monsters are near them. Because there are so many secret doors, if anything looks like it might be one, you're best advised to try it. Finally, use your weapons appropriately. You know the chainsaw is

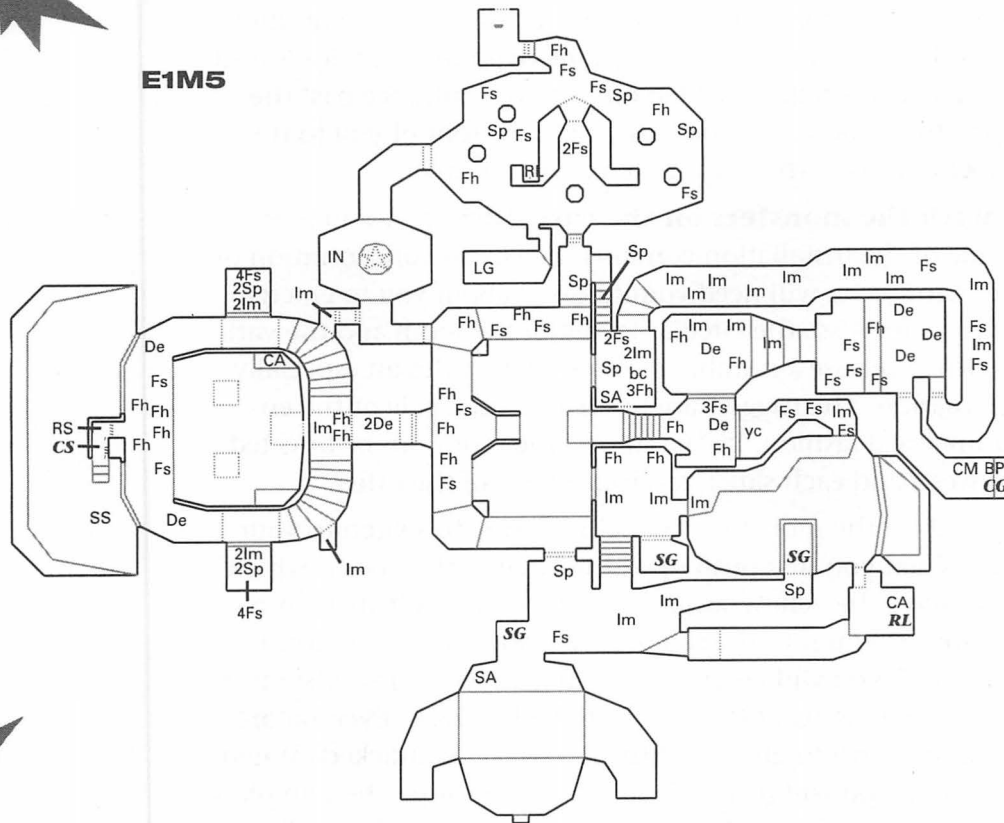

FIGURE 4.5B PHOBOS LAB BLUEPRINTS. Monsters, weapons, and artifacts map.

your best bet for fending off Demons at close quarters. When running down darkened corridors, let the chaingun clear the path before you.

STEP BY STEP THROUGH PHOBOS LAB

Surviving the initial onslaught: The apparent calmness at the start of this level only lasts a few breaths. As soon as you cross over the pool of slime, a small army of Former Humans, Former Human Sergeants, and Imps will descend upon you from the east side. If you are playing at a harder degree of difficulty, you will also be charged by one or two Specters. As you might have gathered from previous levels, when confronted by a horde, your best ally is the rocket launcher. If that's asking

too much, then rely on the chaingun. You need a strong concentration of firepower to slow down the advancing gang of ghouls. But don't wait until these monsters encircle you. Step out into the entrance past the slime and open fire rapidly. Use the barrel right in front of you to thin out the number of beasts who want to have you for lunch.

Dealing with the monsters on the east side: The room at the eastern extreme of the installation contains the largest concentration of monsters. Therefore, you will need your full wits about you to emerge alive from this room. Also, the circular layout of the room and the various triggers (which release a number of monsters) creates an especially challenging situation. The triggers are located on each side of the entrance in symmetrical fashion. In fact, the whole room can be bisected (from east to west) and each side is a mirror image of the other.

To be prepared for the monster onslaught, be sure to switch to your machine gun. When you first push open the latch to this room (which requires you to have the yellow security card), you will advance onto a platform that lowers you into the room. Just as soon as the platform touches the ground, you will be under a frontal attack almost instantly—especially if you are playing at the harder difficulty levels. Even before leaving the platform, try to dispose of the first wave of attackers. When you enter the room you will be the target for two Imps perched on platforms north and south of you. Shoot both of them before descending towards your right (in a northerly direction).

After taking the last stairstep, you will trigger both platforms where the Imps were perched. Each of the platforms has a Stimpack you can grab, should you need it at this point. As you continue further west, turn to face the stairs. You are about to trip another trigger which will raise the secret doors at the north and south ends of the room, releasing another slew of monsters. Before you cross the trigger, you might want to switch to your rocket launcher. Once you trip the trigger, the secret doors will raise and a torrent of Imps and Former Humans will spew out. (In the harder levels, you might also encounter a couple of Specters.)

Fire your weapon and fight your way back to the top of the stairs where you can pick off the opponents that emerged from the south secret door. Then turn back and go towards the west side of the room.

Switch back to your chaingun and shoot any enemies in sight. Use the barrels to your advantage. Having disposed of every monster in the room, you are ready to begin unlocking its remaining secrets, and this room is loaded with them.

UNCOVERING PHOBOS LAB'S SECRETS

You will come upon the first trigger, t1, when you enter the small balcony looking over the ooze pool at the east side of the lab. This trigger causes the zigzag platform p1 to rise from the ooze.

The first secret door, da, is found between two toxic waste barrels on the south wall of the small room leading to the zigzag walkway. Behind this wall you will find a shotgun and some shells.

Follow the zigzag walkway into a small area where you can grab a yellow security card.

Take a jump from the zigzag walkway into the ooze and head for a small indented area just east of the balcony. This is secret door db. Push this door open. Inside you will find a Combat Armor vest, a rocket launcher, a rocket case, and a Medikit.

At the very west end of the Lab, inside the semicircular room, you will find a small indentation on the west wall, where a Medikit sits. Push secret door dc behind the Medikit and you will be inside a tiny room with a radiation suit. South from this location, push secret door dd and enter yet another tiny room where a chainsaw can be had. Push secret door de, south of you again. You will emerge on a small courtyard where you can grab the Soul Sphere.

Go back inside the circular room, don the radiation suit, and head directly across the ooze to a small platform to activate switch s2. This switch causes secret door d2 to rise. Secret door d2 is found in the central area of the lab, across another pit of toxic slime, and it faces west. When you step on the small platform to activate switch s2, you will notice that the pillars flanking the switch will lower. Jump on the pillar to the right. It will begin ascending. Face northeast and ride the pillar up until you see a Combat Armor vest sitting on a high platform. Jump onto the platform and grab the armor. Then jump back onto the platform near switch s2 and wade through the ooze to the next pillar, which should descend

as you step off the platform. Once again, ride this pillar up, but face southwest this time. When you see an ammo box, jump from the rising pillar onto the elevated platform where you can grab the ammo.

On the northeast corner of the circular room, you can get on top of a small platform where an Imp once stood. The platform will rise. Facing east, you can push through two secret doors and emerge in a room with the one and only teleporter for the level. There is also a Blur artifact in the room. If you ride the teleporter, you will materialize near your starting location in Phobos Lab. You will be staring at the short staircase in front of the room that leads to the zigzag walkway, just northeast of your entry point.

The next secret doors, df and dg, are found in the computer area of the lab at the northeast end of the installation. Both of these secret doors are found along the south wall of the room. Secret door df is the first one you come to on the ideal route. Push this secret door that for all purposes looks like a simple computer panel. Behind this door you will find a computer map, a chaingun, a backpack, a Medikit, and a box of ammo.

The next secret door, dg, is just east of df. Push this door open and follow the darkened corridor north, then west, and finally south, to a small room where you will find a blue security card and also a wall switch s3. This switch causes secret door s3 to rise. That secret door is located at the northwest corner of the room.

As you enter the final and very dark room at the north end of the lab, stick to your left and find a small opening that leads down a narrow corridor to the light amplification goggles and a rocket. If you continue along the left (west) side of the room, you will eventually find the exit to this level.

CENTRAL PROCESSING

If you like deductive reasoning and have a penchant for fighting in tight quarters, then you'll love this level. This level is deceptively simple. Laid out in a rough triangular shape, Central Processing has some nice surprises.

To have access to the entire facility, you must find and use all three security cards. You can finish the level with only the blue and red security

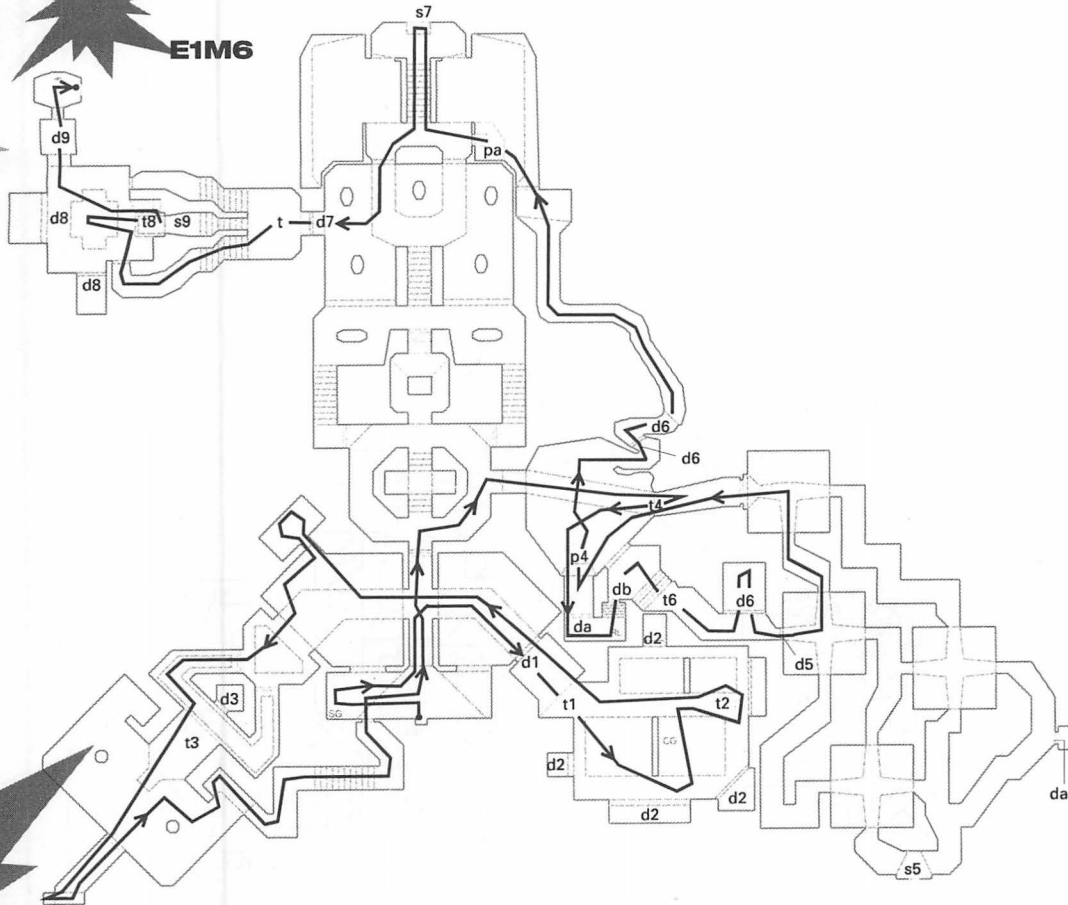

FIGURE 4.6A *CENTRAL PROCESSING BLUEPRINTS. Ideal route map, indicating triggers and switches.*

cards, but why spoil the fun? To grab each of the cards, you'll have to fight hard and fight well. The southeast corner is made up of four interconnected, nearly identical square rooms. After only a few moments in this maze, you might feel like screaming for a guide. But don't despair. Luckily for you, there is a Computer Level Map in this area. Find it and save the day.

This level also introduces a new trigger device. Three of the triggers in Central Processing cause doors to close for spans of 30 seconds. This means that once you enter the rooms where these triggers are found, you're sentenced to stay in there and fight it out for at least that long.

As far as weapons are concerned, you'll be able to get your hands on a chaingun, a rocket launcher, and, in the higher levels, a hidden shotgun. Depending on the level you are playing, the ammo might include several individual rockets, various rocket cases, shell cases and ammo boxes. You can also load up on your ammo by finding 2 backpacks in this level.

GENERAL STRATEGY FOR CENTRAL PROCESSING

As mentioned at the outset of this level, you must have at least the blue and red security cards to be able to escape from Central Processing. And if you choose to bypass the yellow security card, there is only one way to make it. So if you want to have more than one avenue for exiting Central Processing, then your strategy should be to secure all three security cards. And speaking of securing the cards, there is a definite order in which you must get them. You cannot access the yellow card without the blue card. But the area where the blue card can be had is accessible only if you have the red card. Thus, you must get the cards in the order red, blue, and yellow. This fact alone will outline a big part of your strategy.

Because the open space for fighting is somewhat reduced in this level, you must make the most of it and utilize your weapons well. Because you know there are two radiation suits in this level, you have to expect that you'll need to cross slime areas. When you do, look for hidden doors and corridors. They often lead to useful artifacts. The southeastern area of Central Processing may be hard to navigate without the aid of a map. If you find yourself running in circles in this area, you'd better start looking for the secret door with the computer map as there is no one you can stop and ask for quick directions.

The level of fighting in Central Processing may also require that you build your health and armor as much as you can. So don't pass up any Spiritual Armors and health potions. And always try to remember where the Medikits are in case you need to run and grab them.

STEP BY STEP THROUGH CENTRAL PROCESSING

The recommended route for this level ensures you get all three keys and visit nearly every area. Notice that the route completely bypasses the room just north of the center area. The only reason you might want to visit this room is if you need to boost your health and tend to your wounds. The room contains more than enough Medikits to patch you up and make you well again. The outlined route, however, is not the only way to reach the exit. After getting all three keys, you can choose to run straight north, up the main hallway, in which case, you would also pass through the room with the Medikits.

Grabbing the red security key and emerging victorious: To amount to anything—or really to go anywhere—in this level, you must at the very least possess the red card. The red card will then allow you to access the area where the blue card is found. As you know, you can clear this level with only these two cards. But it just so happens that the red security card is surrounded by a perimeter trigger that you must break to grab the key. That trigger causes a total of five secret doors to open and unleash a great many Imps, Former Humans, and Former Human Sergeants. If you've ever wondered what it's like to be ambushed, this should give you a most definite idea.

As you enter the computer area just east of your initial entry point, you will set off a trigger that causes the door behind you to shut for a period of 30 seconds. If you have a chaingun from the previous level, this is the time to pull it out, especially if you are playing at a high degree of difficulty. After only a couple of steps into the room, you will be assaulted from your left. Dispose of the first wave of Former Humans and Former Human Sergeants meandering the room. Notice the high concentration and close proximity of barrels in the room. You know that where there are barrels, there can be explosions. These barrels will help you make your escape from the room after you've clenched the red security card, so try not to blow them up until you've got the card.

If you haven't got a chaingun and sufficient ammo, go on the east side of the southernmost dividing panel. There is a chaingun and some ammo. Grab them without hesitation. If there are no additional marauders in the

room, you might want to leave the key until last and pick up any other ammo boxes, health potions, and Spiritual Armors that can be had.

When you are ready, position yourself next to the security card so you can start running out of the room as soon as you grab it. You won't be

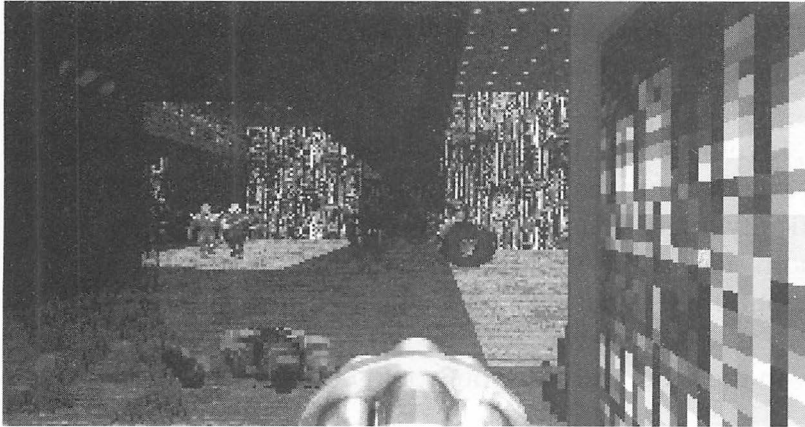

able to hang around; if you do, it won't be for long. So grab the security card and run like hell. The shortest route out is to run between the panels. When you place some distance between you and the monsters, open fire, and open fire wide. As the monsters come after you, they will tend to congregate around the barrels. At this point, you know what to do. Aim for the barrels

and set off a nice chain reaction and a big tiered explosion. Then just pick off the survivors.

If you have absorbed some damage, go back into the room. Look inside each of the secret door areas and pick up all the health aids you can get.

Reaching the Soul Sphere in the courtyard: If you haven't figured it out yet, the only way to reach this level's exit without the yellow key is to go down into the slime and traverse the narrow canal just north-east of the installation's center. It just so happens that this same canal leads to a Soul Sphere at the eastern side of the courtyard. But reaching this area isn't just a matter of jumping into the ooze and making a run for it. There is a secret door near the entrance of the canal that can only be activated by trigger t6. Trigger t6 is located just east of the central room, halfway up the stairs in the crate-like room. If you are following the ideal route, after making it through the maze, you'll eventually find yourself in this room. By simply walking over the steps, you will activate the trigger. This trigger also causes the secret door behind you to open and release a bunch of monsters. The chaingun is definitely recommended for this deadly scuffle. If you hold your ground at the top of the stairs and are able to take partial shield behind the wall, then you will

have a better chance of picking off your opponents the second they step into view.

Once you clean them out, you can go behind the secret door and grab a shotgun, a rocket, and some Medikits. Then continue along the outlined route. There, grab the backpack, the rocket launcher, and the Blur artifact. Then push through the secret door to come out in the small room behind the platform, where you will find a radiation suit. Grab it and head north in the ooze.

At this point, you are invisible, invulnerable to the ooze, and have a substantial load of ammo. You're even packing the rocket launcher. If you are playing in the harder difficulty levels, you will be accosted by a bunch of Imps and Demons on both sides of the walkway. They might seem a bit confused, for they cannot fully see you. Take advantage of this situation. You should exit the room as you blast away. (You do not want to fire while remaining stationary in the room, because you would be giving away your position.)

Eventually, and before too long, make your way through the canal. Remember that the suit will hold out for only 120 seconds. If you are met by additional Imps in the first elbow of the canal, rely on the chain-gun. You may have to back out into the wider area to avoid the Imps' fireballs. Upon reaching the end of the canal, you will wind up on a small area with two additional rocket cases, another backpack, a Medikit, and some ammo and shell boxes. After picking up these goodies, push the secret door at the north end of the small walkway. Hop down into the courtyard. You are at a no-return point, because the secret door you just opened works only one way. Walk up to the pillar with the Soul Sphere. It will lower as you get near. Grab the Soul Sphere, get on top of the pillar and ride it up. Face the wall and push the secret door. You are now in the north end, inside the installation.

UNCOVERING CENTRAL PROCESSING'S SECRETS

The first trigger in this level, t1, is found at the threshold of the computer room just east of your entry position. When you trip the trigger, the door behind, d1, will close for a period of 30 seconds. The second

trigger, t2, is a perimeter trigger that completely encircles the red security card. When you cross the perimeter, t2 causes five secret doors around the computer room to open, releasing a most unfriendly surprise party of Imps, Former Humans, and Former Human Sergeants.

The next trigger, t3, at the southwest point of the installation, causes secret door d3 to open, letting out a Demon and, in harder levels, a couple of Imps. Behind this door you can find a couple of Stimpacks.

After grabbing the blue security card, facing southwest, you will see a dark entrance. You must jump into the ooze and follow the short corridor leading to a narrow platform. The platform lifts you to a small enclosure housing a Soul Sphere. The next platform is found just northeast of the tunnel in the ooze. Sitting on this platform are a Security Armor and various Medikits. Following the corridor you will run into a couple of rocket cases, a Blur artifact, and light amplification goggles. At the north end of the corridor, you will reach another secret door that opens up in the room where you first entered Central Processing.

The next trigger, t4, is found at the end of the walkway leading to the maze area at the east end of the installation. This trigger causes platform p4 to lower. Behind this platform, you will find a Medikit and a radiation suit. Secret door da is located at the far west end of the maze area. Behind it is the Computer Level Map.

The first switch in this level is s5, at the southernmost end of the maze area. Activate this switch to open secret door d5 on the west side of the maze.

Trigger t6 is located halfway up the stairs outside of the maze area. When you trip t6, three secret doors are activated. The first ones you'll notice are d6 north and d6 south. The southern door raises in the narrow ooze-filled corridor that eventually leads to the northeast side of the installation. The other secret door is just east of the trigger's location. This door rises and lets out a few monsters. In the harder difficulty levels, that door also hides a single rocket and a shotgun. The same trigger also opens up a secret door along the sinewy ooze vein running north-south just northeast from the central area.

Up the stairs from trigger t6, you will enter a small room and come upon a Security Armor, the yellow security card, and a backpack. The

next secret door is found at the southwest corner of this room, just behind the Security Armor. Push open that door and you will enter yet another small room where a second backpack can be had as well as a Blur artifact and a rocket launcher. The next secret door in this succession is at the north wall of the east side of the small room. Push that door and emerge behind platform p4. A radiation suit hangs waiting here.

If you follow the sinewy, ooze-filled corridor, you will wind up on a small surface with two rocket cases, a backpack, some Medikits, ammo, and shell boxes.

The next platform is located on the east side of the courtyard. When you approach, it will lower and give you access to a Soul Sphere. To reach the next secret door, you must get on top of the platform where you got the Soul Sphere and ride the platform up. Then face the wall and push.

Switch s7 is at the far north end of the Central Processing building. Activate this switch to open up secret door d7, which eventually leads to the room where the exit to the level finally becomes accessible. The next trigger is found a couple of steps west of secret door d7. This is another timed trigger, causing secret door d7 to close for 30 seconds.

Trigger t8 is just west of switch s9 in the northwest point of the structure. This trigger activates two secret doors. The secret doors release a good number of Imps and Former Human Sergeants. Finally, s9 causes secret door d9 to open at the north end of the room. Behind this door you will find the level's exit. But you must first deal with the Specters lurking in the room leading to the exit.

COMPUTER STATION

In this level you must take a few leaps, both literally and figuratively. To be sure, ooze is nasty stuff, pernicious to the body and the mind. But sometimes, jumping into the ooze can help you uncover unexpected benefits. Depending on how good your control is, your time in the ooze may be limited to just a couple of plunges.

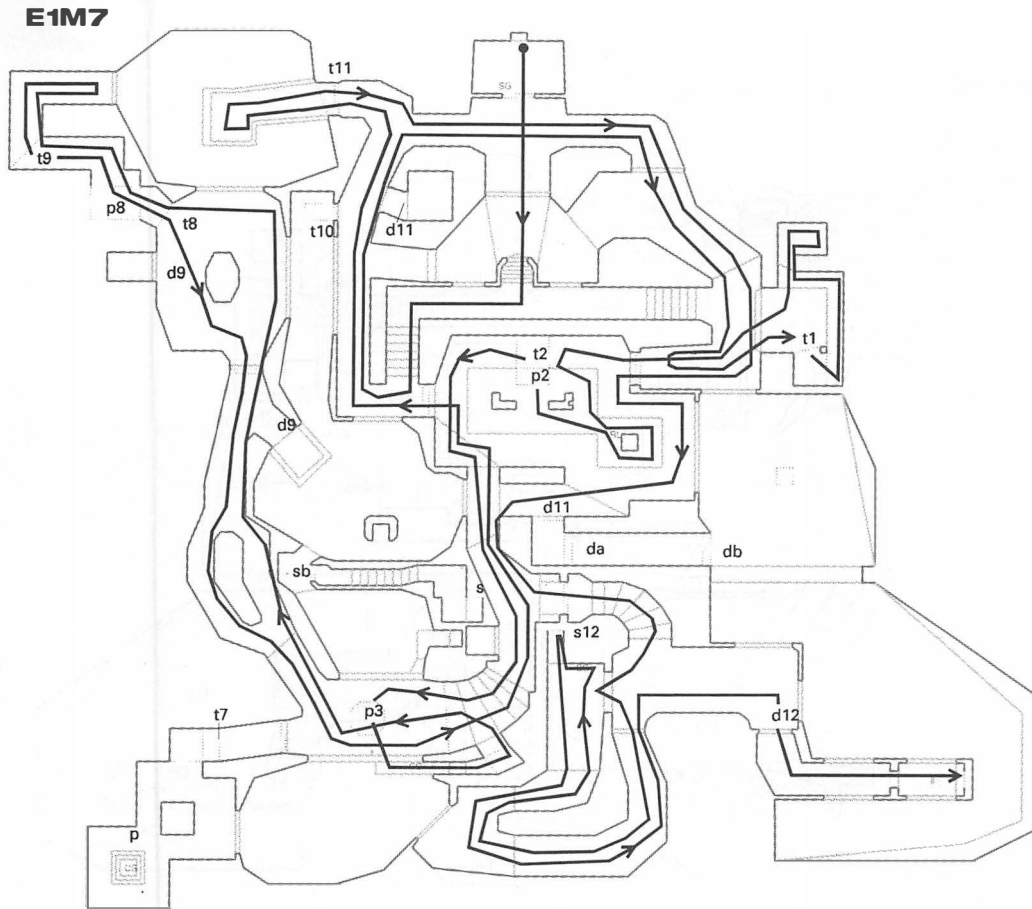

FIGURE 4.7A COMPUTER STATION BLUEPRINTS. *Ideal route map, indicating triggers and switches.*

To exit this level, you must gain possession of all three security cards. Not only that, but there is a definite order in which the cards can be had. This level is also mined with triggers. So be very careful of your steps. And speaking of steps, this level requires you to travel the same paths more than once. You may get the feeling that you are running around in circles. Don't let this bother you. Eventually, you'll get to where you need to go.

GENERAL STRATEGY FOR THE COMPUTER STATION

You know you will need all three security cards to exit the Computer Station. There is no other way. This means your strategy should be to seek out each of the security cards and to stay alive to be able to use them. But getting even the first key can seem an odyssey.

Your fighting strategy should be a suitable combination of heavy artillery—we're talking rockets—and sniper style, or the more daring shoot-on-the-run technique with your shotgun and chainguns. Sometimes, when you're surrounded by a an unappreciative crowd, you simply must resort to the rockets.

This level presents you with some good vantage points where you can pick off your opponents in sniper fashion. Take advantage of these situations rather than waiting for a more aggressive, but often fatal, frontal confrontation.

The latch that eventually leads to the exit requires the blue security card. However, the blue security card is behind a latch that requires you to have the red one to open it. But the only possible way to reach the red card is by opening the latch that clears the way to the entire west vein of this structure. As you might have guessed, said latch will not open without the yellow card.

STEP BY STEP THROUGH THE COMPUTER STATION

Surviving the initial monster onslaught: As with other levels in the first episode, you start out, inconspicuously enough, in a sealed room. But the second you open the latch in front of you, watch out for the fireworks! If you have a good selection of weapons to begin with, you might have to call on a rocket or three and definitely the chaingun. Just pray you don't have to resort to the chainsaw. When things thin out a bit, reach for your trusty shotgun. (If you are playing at a lower difficulty level, things will not be as drastic.)

If you have the rocket launcher, stand squarely in front of the latch. Throw it open and then back up a few steps as you release three or four rockets to dampen the spirits of the Imps and Specters heading in your direction from the small stair case directly south of you. Then exit the room and head south toward the Security Armor. If you do not have the benefit of the rocket launcher, grab your chaingun and stand to the left side of the latch so as to offer minimal target angle to the enemy, and throw the latch open. Don't wait for the first monster to show its ugly face. Aim for the barrel to the right side of the latch and fire away. That will clear a few monsters out of the way.

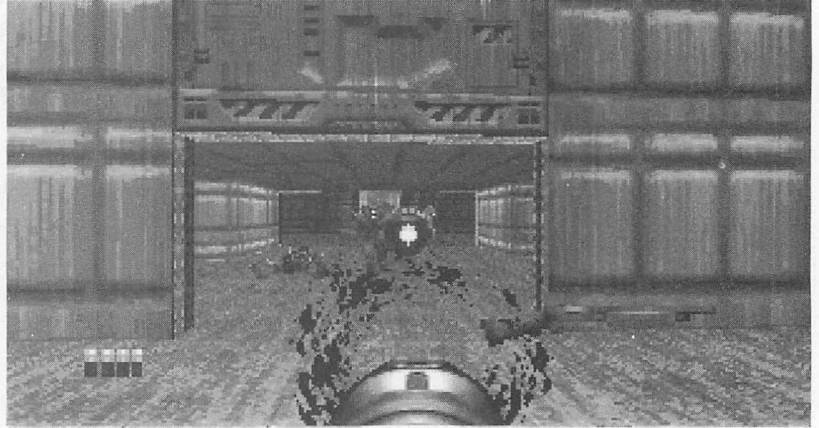

As the avalanche of Imps and Former Human Sergeants descends into the room, welcome them with a veritable bullet shower. If a Specter manages to enter the room, it's chainsaw time. When you get a second to breathe, run out and head south, directly for the Security Armor in the middle of the floor. Run up the short flight of stairs and turn right, then follow the corridor and pull a quick left. Turn around rapidly and fire away at any monsters in pursuit.

Reaching the secrets at the southwest end of the Computer Station: Solving this area of the structure is the only way to uncover its barrage of secrets. We'll tell you about two of them here:

- A small passageway that leads to a chaingun, a backpack, and a secret door
- A small ledge that leads to the computer map.

To find out about the other four (radiation suit, hidden rocket case and switch, and Soul Sphere), you must read “Uncovering Computer Station’s Secrets,” later in this section.

The scene at the southwest end requires you to take flying leaps into the ooze from a high altitude—hopefully only twice. Timing and control are paramount. And, as always, before you can concentrate on the physical feats expected of you, you must also put away a respectable number of Imps and former comrades. As you reach the foot of the stairs bending westward and up into the room, you have a nice wide angle and some respectable distance between you and the bad guys. These two ingredients, plus the fact that there are enough monsters to form a small platoon, and a few strategically placed barrels, present the right picture for a few rockets. After smoking every monster in sight, walk up the stairs—don’t run—and if you feel daring enough, switch to your chaingun. Your last step on the stairs sets off a trigger; the central column in the room descends, unloading a crazed party of Former Human Sergeants. If you’re still carrying the rocket launcher, unload one before the column reaches the ground. If you have your chaingun, sink your finger into the trigger. The key is to not leave many Sergeants standing by the time the column reaches ground level.

When things have finally quieted down sufficiently, climb the column and look south. When the column is high enough, run feet-first into the ooze pool at the southwest end. (If you wait too long before jumping, the column will continue rising to enclose you in a circular recess in the ceiling. If this should happen, don’t worry. A switch on the wall of the recessed area will cause the column to lower again.)

The second you hit the ooze, run to the northeast corner and hop on the narrow walkway with the chaingun and Medikits. Continue eastward and a trigger will cause the secret door in front of you to rise. Go inside the small room. There a backpack awaits. As you reach for the backpack, another secret door rises, taking you out into the staircase once again.

Hop onto the column a second time and ride it up. This time look directly northeast. You’ll be able to spot a narrow platform on the side of the wall. You must jump and land in this tiny area, or else fall to the

ooze below. The narrow platform takes you to the recessed area where the computer map awaits. The key to a good landing is pointing just the right way. Also you must be able to either stop once you land, controlling your forward inertia, or just run right into the recessed area. If you do it right the first time, you will activate a trigger as you go for the map. This trigger lengthens the platform, permitting you to walk on this narrow ledge back into the room. However, if you should happen to fall into the ooze, don't worry, there is a way out and some other secrets along the way, as detailed in the following paragraphs.

UNCOVERING COMPUTER STATION'S SECRETS

The first trigger, t1, is found inside the computer room with the blue floor in the northeast corner. This trigger lowers platform p1, which you can ride up into the narrow walkway to reach the yellow security card. Trigger t2 is in the north side of the central computer room. Crossing either of its sensors lowers platform p2, where you hitch a ride to the upstairs monster nest. Here you'll find a rocket launcher and two loose rockets.

Upon reaching the southwest room, you will trigger t3 at the top of the stairs, thus lowering the column, p3. The next trigger, t4 (which you won't be able to access unless you jump into the ooze), raises secret door d4. This door opens into a small room where there is a backpack. Trigger t5 is also inside this room. It activates secret door d5, which simply takes you back to the stairs.

Trigger t6 is only reachable if you've managed to jump into the small area by jumping from the center pillar in the room. Once you cross it, trigger t6 causes the small ledge platform p6 to emerge from the wall, allowing you to walk back into the floor of the room. Trigger t7 is also in the near vicinity, behind the latch at the west wall of this same room. When you activate this trigger, a platform will lower and let you climb into a darkened computer room where the chainsaw can be had as well as a rocket case and some additional ammo.

Trigger t8 is at the northwest corner of the big room. The trigger will lower platform p8, giving you access to the sinewy corridor where the red security card awaits. Along this corridor, you will activate trigger t9, which has no immediate apparent effect. However, it causes three secret doors to open, each unleashing many more monsters.

The next switch becomes reachable only if you have jumped north into the ooze from the central column of the southwest room. Heading northwest in the ooze, you will reach a bottleneck where a radiation suit hangs. (You'd do well to grab it.) East of the suit is switch sb. Behind this switch is a door to a narrow staired corridor. At the top of the stairs, you will find a rocket case and a switch. Hit this switch to lower the secret wall around the chainsaw in the southwest room.

Continuing northward in the ooze, just past the bottleneck, you will reach a wider pool of ooze. The pillar just east of the entrance hides a Combat Armor. Even further north in the ooze, you will come upon a Soul Sphere on top of a narrow platform. The platform has a perimeter trigger, t10. When you step on the platform, it will cause the secret door in front of it, d10, to open. If you emerge from this secret door and go north, you will reach the latch requiring the red security card to open. Behind this latch is the blue security card and trigger t11. This trigger activates two secret doors. The first one is found across the way from where the Soul Sphere was. This secret door will unload a number of Former Human Sergeants. The second secret door is quite a distance away. In fact it is just south of the central computer room. The door releases another sour bunch of guys and also gives access to another secret door, da, which itself leads to yet another secret door, db, and out into the only courtyard of this installation. In the middle of the courtyard you will find a Blur artifact.

The next switch, s12, is nested down the central southern end of the structure. To reach it, you must go through the latch requiring the blue security card, then up the stairs that bend south. Follow the foot-shaped corridor, and you will dead end with switch s12. This switch causes the latch at the southeast end to give way—to the exit for the level.

PHOBOS ANOMALY

Unlike all the levels in the first episode, Phobos Anomaly does not present you with a baffling architecture and a complex layout. The blueprint map may not look like much—just a 5-point star shape surrounded by a large open area. This level's surprises and challenges come in the shape of two formidable creatures, two very mean and powerful Barons of Hell. These guys are the bosses for this level. Perhaps you've heard of the cat and mouse game. Well, guess who gets to be the mouse for a while?

This level puts an end to the first episode and sets the stage for things to come. If you are a shareware user, this is the end of the line for you. However, if you haven't uncovered the exit to the secret level back in the Toxin Refinery installation, you still have a *tour de force* in front of you: the Military Base, which is covered in the last section of this chapter.

PHOBOS ANOMALY: LIST

The economical architecture of this simple structure reveals a small number of secrets: 3 switches, 3 platforms, 1 trigger, 1 secret door, and the second and last teleporter in this episode. The useful artifacts include 2 computer maps, a Blur artifact, and a Soul Sphere. The weapons you might find consist of a chaingun and a shotgun. There are also various ammo boxes and Medikits lying about.

GENERAL STRATEGY FOR PHOBOS ANOMALY

Regardless of the difficulty degree at which you are playing this level, Phobos Anomaly will definitely test your perseverance and tenacity. The only way to reach the exit in this level is to kill both Barons. That is it. You really don't have to solve any architectural puzzles. The layout is simple enough. The reptilian brain in your overly evolved cranium must take over. In addition to the Barons, if you are playing at a harder difficulty level, you will also have to contend with hordes of elusive and deadly Specters (and, for good measure, a *mélange* of Demons thrown in in the first part of this level).

E1M8

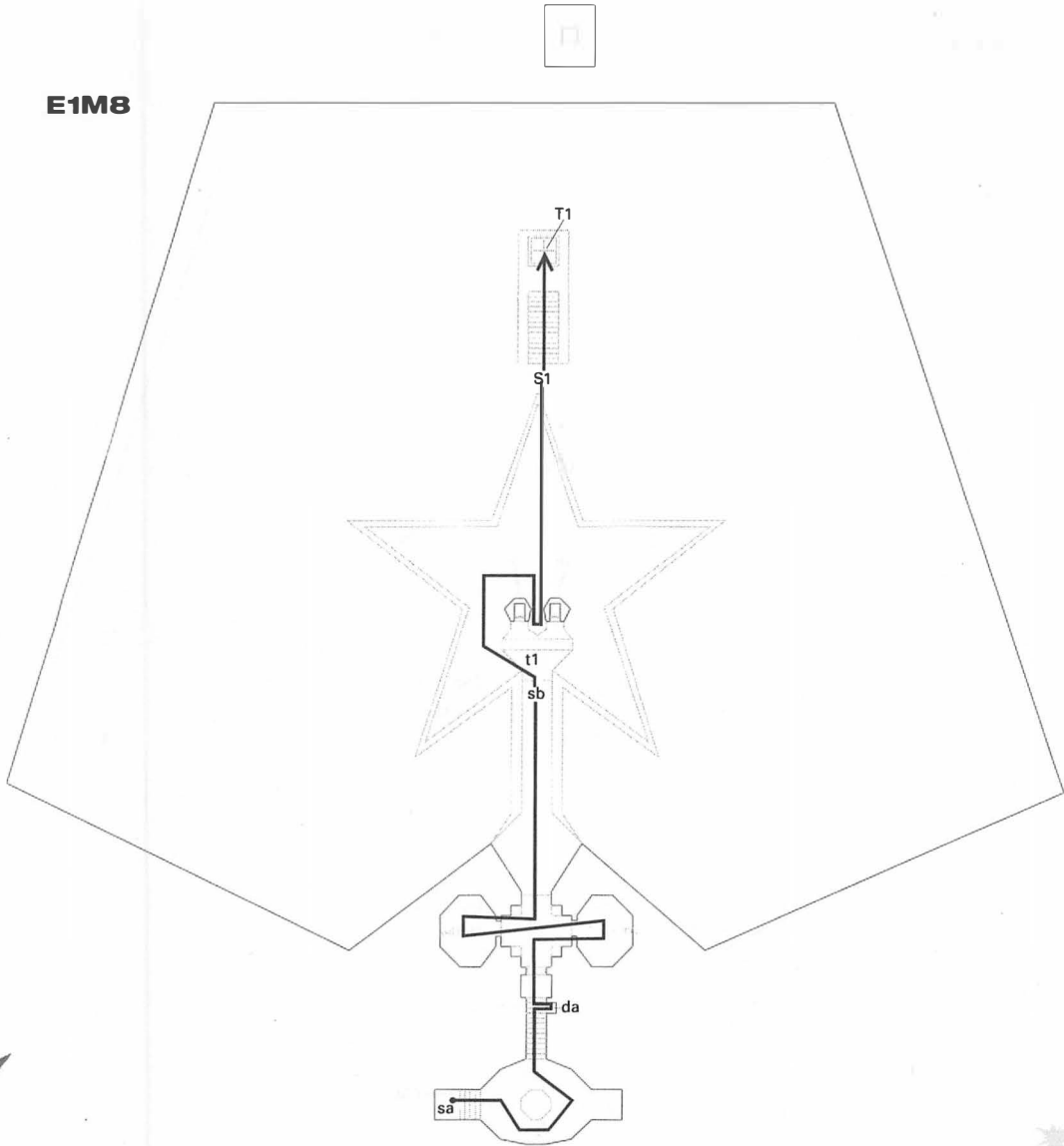

FIGURE 4.8A PHOBOS ANOMALY BLUEPRINTS. *Ideal route map, indicating triggers and switches.*

E1M8

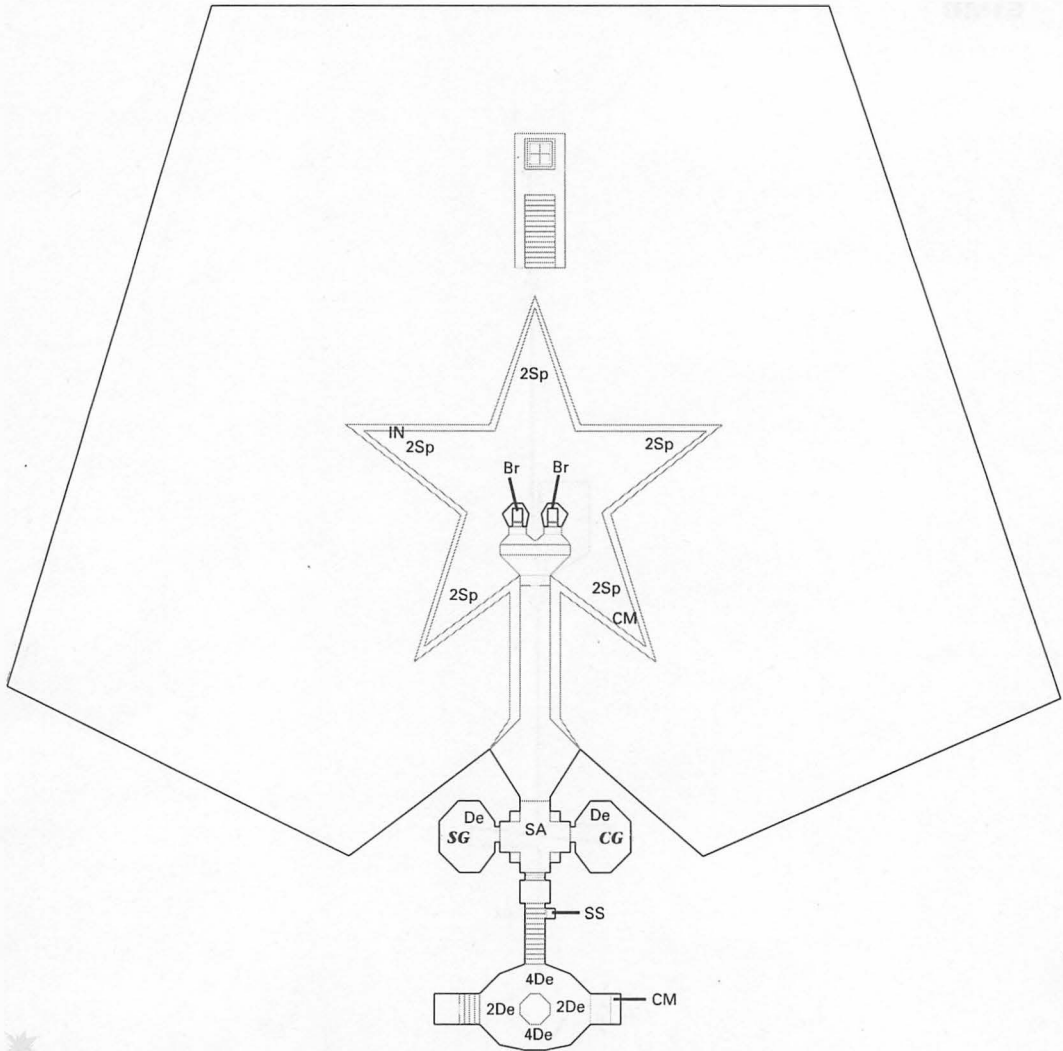

FIGURE 4.8B PHOBOS ANOMALY BLUEPRINTS. Monsters, weapons, and artifacts map.

Given the nature of your opposition, to succeed in the Phobos Anomaly you must rely on a carefully orchestrated show of arms—the shotgun, the rocket launcher, and the chainsaw. The Barons are just too tough to take down with the firepower afforded by a shotgun or a chaingun (although such cases are not completely unheard of). Just remember that a Baron will succumb under the weight of 5 well-placed rockets. In fighting a Baron, you have to give yourself the space to blast rockets. The Baron's claw can be much worse than his energy discharge. A single scratch can waste away 10 to 80% of your health, while an energy blast can drain you between 8 and 64%. Therefore, your main consideration in facing off a Baron is to never let yourself see the whites of his eyes. Keep a Baron at a distance and give yourself enough room to sidestep his energy blasts.

If you are also facing hordes or Specters, you know the best way to break a party is to drop a couple of rockets in the midst of the congregation.

STEP BY STEP THROUGH THE PHOBOS ANOMALY

Dispensing with the Demon party that welcomes you upon your arrival: You will start this final level in a small, squat room with nothing but a switch in front of you. Upon pressing the switch, the wall will rise to reveal a small pool of ooze below you and a bevy of Demons running around frantically, as Demons tend to do. Luckily for you, the ooze pool and the Demons are surrounded by a circle of barrels. From the safety of your vantage point (no Demons can climb to where you are) aim for a barrel at the right or left side of the circle. You want to cause a chain reaction and let the ensuing explosions cut down on some of the work for you. It is likely that most, if not all, of the Demons will die. You can then simply pick off any remaining Demons—all without having to set foot in the room below.

Fighting off the Specters in the star-shaped area and getting down to business with the Barons of Hell: When you reach the north end of the hallway leading to the star-shaped room, you face your greatest challenge in this level. If you are playing at the Ultra-Violence level, you will have to face not just the Barons, but also a great many

Specters. The Barons emerge from their upright coffin-like enclosures the second you take your first step into the room. The Specters, however, will spot you even before that: as soon as you are visible.

One technique for dealing with the hordes of Specters is simply to stay put at the gate and thus avoid waking up the Barons. From the gate, you can then launch rockets in the direction of the Specters. As you know, Specters are very difficult to spot. For this reason, you should launch rockets in the general areas where they can charge from. These areas are to the left, middle, and right of your entry position. On the left side of the coffin structures there are quite a few ooze barrels. You should unload at least four or five rockets in this area. Launch a couple more between the coffin structures, and yet a few more to the right side. If a few stray Specters survive the rockets, they'll be headed in your direction. Again, you can stay put and pull out the chainsaw. Use it left and right but avoid, at all costs, being forced from your position. That will only awaken the Barons.

When you have a second to collect yourself, you can dash left and around the coffins to position yourself squarely in the back. You can also run directly ahead and jump down from between the coffins, getting to the same desirable spot. From this position you can pan left and right of the Barons and begin taking potshots with your rockets. However, if you want to increase your chances, you should go for the Blur artifact located at the northwest point of the star-shaped room. With the added benefit of partial invisibility, go back behind the coffin structures and start picking your shots. Try to be as accurate as you can.

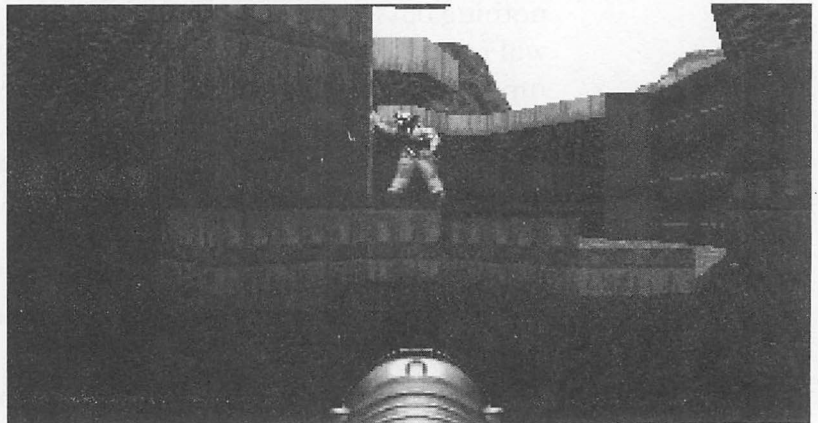

Ideally you want to keep the Barons in the front side of the coffins. For this reason you should alternate your attacks left and right of the coffins.

Of course, you can also take shots from the center behind the coffins. After offing the second Baron, the walls around the structure will descend and you're home free (seemingly).

UNCOVERING PHOBOS ANOMALY'S SECRETS

The first switch you'll run into is right in front of you when you first access the Anomaly. This switch raises the wall to reveal a bunch of Demons dancing around a pool of ooze below you. Right across, directly east from this position, there is a platform that activates when you set foot on it. It rises and takes you to a small ledge where you can grab a number of Medikits and a computer map.

The next useful artifact is just before you reach the bottom of the stairs on the east wall of the narrow hallway. Push secret door da to reveal a Soul Sphere behind it. As you open the next latch, you will walk into a slightly wider room. This room is flanked by two dark rooms. The west-side room contains three shell cases and a shotgun. The east-side room contains four ammo boxes and a chaingun.

Switch sb raises the wall at the north end of the hallway leading to the star-shaped room. When you stand on the narrow platform, you are raised into the star-shaped room. The first and only trigger, t1, is just a step away from this position. When you activate it, the Barons of Hell emerge from their upright coffins. Each point of the star-shaped room contains either ammo or shell boxes and Medikits. The northwest point contains a Blur artifact.

The next to final secret in this level is only visible if you have managed to kill both Barons. When you do, the entire walls surrounding the star-shaped room descend, revealing a large open area around the periphery. Just north of the star shape, there is a small structure with a switch on its side. Activate this switch s1, and the platform stairs begin to rise from the ground, leading you to the second teleporter in this episode.

Now you have no choice but to ride it. It's the only way out. Next stop is Shores of Hell.

MILITARY BASE: THE SECRET LEVEL

The only way to visit the Military Base is to find the exit leading to the secret level back in the Toxin Refinery. If you make it through the Military Base, you will return to your normal sequence in episode 1. This means you will continue with the fourth level, Command Control.

The Military Base is laid out in a roughly square shape with a central stone courtyard. There are rooms in every corner of this square as well as an extra room between each corner. This brings the number of main rooms up to eight. There is also an extra room protruding from the east side of the main structure and a central stone courtyard connecting all rooms. In addition, there is a small room that runs diagonally from the east room to the room directly south of the installation's center. What all this means is that there are lots of secrets in the Military Base, for each room encloses at least one. The exit in this room is found behind a latch that requires you to have a blue security card to open it. But to finally get the blue card, you must first gain possession of the yellow and then the red one.

The action in this level is fast and furious. There are more Demons, Imps, and Former Humans than you can shake a chainsaw at. You also get to see your first teleporter in this level—only a hint of what lies ahead. Finally, in this level those who persevere will find every weapon that's available in the first episode—but getting them involves some fancy footwork.

MILITARY BASE: LIST

There are 2 switches, 5 secret doors, 6 triggers, and 8 platforms. There is 1 Security Armor, a shotgun, a rocket launcher, a chainsaw, a chain-gun, a backpack, and some assorted hidden ammo (a rocket case, a shell case, a backpack, etc.). In addition, this level also hides all three security cards.

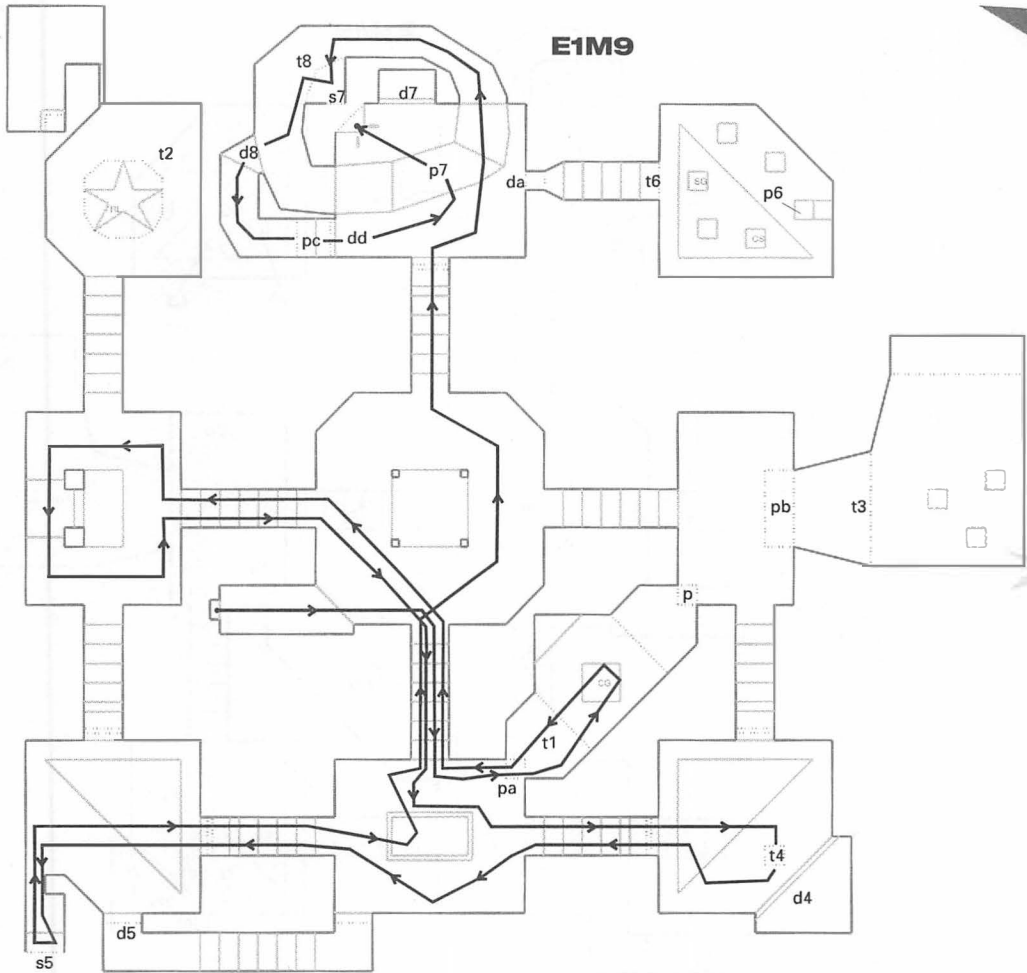

FIGURE 4.9A *MILITARY BASE BLUEPRINTS. Ideal route map, indicating triggers and switches.*

GENERAL STRATEGY FOR THE MILITARY BASE

In this level you must gain possession of all security cards, in order (yellow, red, blue), before you can reach the exit. Even in the lower degrees of difficulty, this level is plagued with many Former Human Sergeants; therefore, you should always try to snipe these guys when you find yourself swarmed. The central courtyard has a crated area where

the central courtyard through a set of stairs. You will do well to avoid running into a room. Rather, run in just enough to draw the monsters out. Then run back and pick your shots. The monsters will be most susceptible to attack as they are running up the stairs after you.

STEP BY STEP THROUGH THE MILITARY BASE

Grabbing the rocket launcher and other artifacts in the star-shaped Teleporter: The star-shaped room at the northeast corner of the installation is really a one-way Teleporter, and it is surrounded by a perimeter trigger. The moment you cross the trigger, a number of monsters will teleport to the middle of the star. (These monsters are normally kept at bay in a small room extending north from the star shape.) Grab the goodies and then beat it out of the room as fast as you can. The recommended way to do this is simply to avoid crossing the perimeter and walk to the north end of the room. Then, facing the stairs from which you came, run at full speed across the star and be sure to grab the rocket launcher on your way out. You will hear the growls of the monsters as they materialize. But pay no mind. When you reach the top of the stairs, unload a couple of rockets. If you like, you can also use your chaingun and your shotgun in sniper fashion, taking refuge behind the wall after releasing a few blasts. Ideally, you want to prevent any monster from reaching the top of the stairs, where you might have to scramble and face potential damage.

Securing the artifacts hoisted on pillars in the northeast room: You won't find any monsters in this room—just five items perched on pillars. Initially, it might seem impossible to retrieve such items. But there is a way. A trigger located at the bottom of the stairs causes the platform on the east wall of the room to descend for a few seconds. This is a very small platform. When it rises, you will have a chance to jump to the first pillar and then to hop from each pillar to the next, thereby retrieving all the items. You will notice that the height of each pillar is shorter as you look counterclockwise. This means that you should take your first jump onto the pillar northwest of the platform position. The tricky part is landing and staying on the pillar. Your momentum will

tend to make you fall off. If you happen to fall, you will have to set the trigger and start all over.

Depending on your level of control, this task may or may not be easily accomplished. If reaching each pillar in succession seems impossible, don't despair. The Automap makes it much easier to judge your movement, because you get to see the perspective from the top. (However, remember that before reaching the platform, you must run around each pillar before it will register in the Automap.) Then activate the trigger, reach the platform, and when you are up, turn on the Automap.

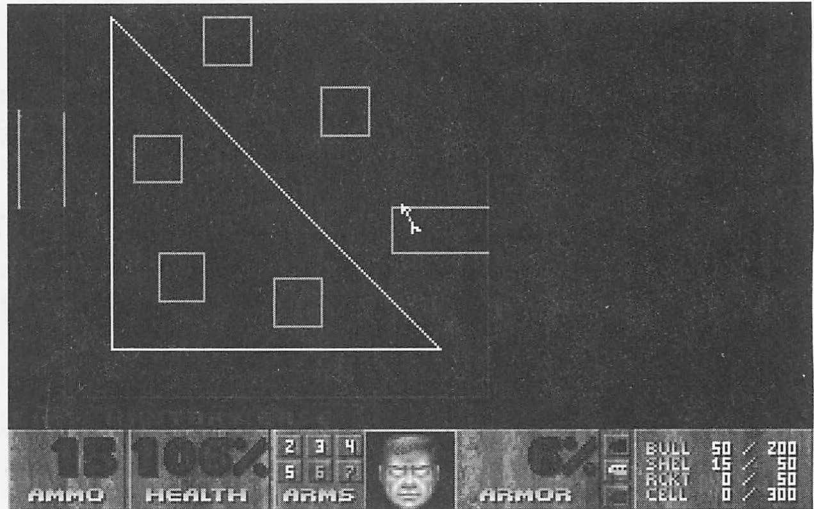

UNCOVERING THE MILITARY BASE'S SECRETS

The first platform, pa, is located in the northeast corner of the room just south of the central courtyard. When you step on the platform, it automatically lowers you to a small room with a nice size ooze pool. In the midst of the ooze is a chaingun and an ammo box. You will want to run to the center area and grab possession of the stuff. However, be aware that as you step off the concrete, you will set off trigger t1, which causes even the dry areas at the northeast and southwest corners of the room to flood with ooze. Lucky for you, a dry area remains at the northwest corner. This area also has a Medikit. Go for it. Then run back across the ooze to your place of entry. As you get near it, the small square platform will appear to let you ride it back up.

Trigger t2 is found north of the room where the yellow security card can be had. When you cross any area of the star-shaped Teleporter in the

middle of the room, monsters from the adjoining containment area will materialize.

Continuing on our route, platform pb is inside the room just east from the central courtyard. This platform lowers you into another ooze room where three Imps are perched high on stone pillars. At the edge of the ooze, if you cross trigger t3, you will cause the pillars to descend. The north side of this room hides a Security Armor.

The room at the southeast corner of the installation has the red security card, on a perimeter trigger, t4. When you grab the key, secret door d4, at the corner of the room, will rise and release a few Imps, Former Human Sergeants, and maybe a couple of other unsavory characters.

At the northwest corner of the Military Base, you will find the next switch, s5. This switch is behind a row of barrels you will have to set off before you can reach it. When you activate this switch, a secret door opens to give way to a small corridor with stairs; also, all four walls enclosing the blue security card sink into the ground. If you go up into the corridor, you will run into a shell case and an ammo box.

The first secret door in this level that does not require a trigger, da, is located in the room where the final exit is found, just north of the central area. This secret door lets you access the northeast corner of the Military Base. In this room, perched on pillars, you can find a rocket case, a shell case, a shotgun, a backpack, and a chainsaw.

The second you step into the room, you will activate trigger t6, which causes platform p6 (on the eastern wall of the room) to lower temporarily. Sitting on the platform is another box of ammo. You must climb the platform and take consecutive counterclockwise hops onto each pillar.

Back in the room where the exit is in plain view, it is also obvious that a deep canal divides the room and prevents you from crossing over to the exit. Underneath the exit switch (on the floor below), however, there is another switch, s7. This switch causes a wide platform to raise from the ooze and bridge the gap in the room above. This means that you have to wade in the ooze to reach the switch. Unfortunately, the switch also causes secret door d7, right next to the exit switch, to open and release a few Specters. As you step on or off the platform where switch s7 is found, you will also set off trigger t8, which causes secret door d8 to



open. This is the path you must take to get back upstairs. But you will also have to deal with a few Imps along the way.

Platform pc will lower if you press the spacebar. As you ride the platform upstairs, you will be in front of another secret door, dd. Push this wall open and get ready for the onslaught of freshly released Specters. (This is a good time to bury the chainsaw into nearly invisible evil flesh.)

**THE SHORES
OF HELL**

F I V E

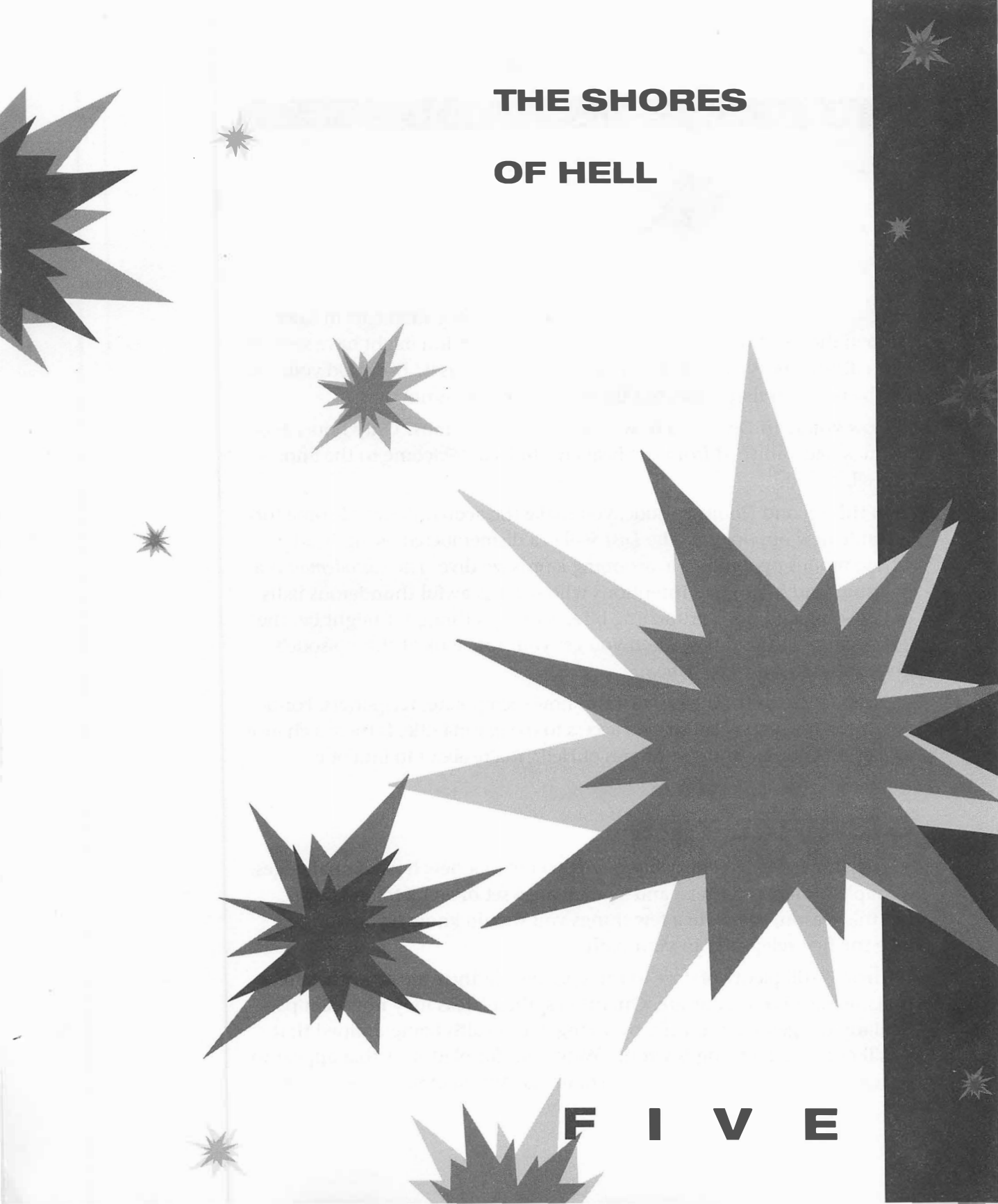

You've endured a most grueling episode. There were moments in Knee-Deep in the Dead where the notion of losing your mind might have seemed like a distinct possibility. But that's all over now. Or, is it? Don't kid yourself. Maybe you won that battle, but the war, as they say, is not over.

Now you're in Deimos. But where the hell is Deimos? Only hours ago Deimos had vanished from the heavens. Indeed. Welcome to the Shores of Hell.

In this second Doom episode, you make the acquaintance of some formidable new opponents. The *Lost Soul* is a dismembered flying head whose modus operandi is a swooping kamikaze dive. The *Cacodemon* is a floating head full of bad intentions who belches awful thunderous balls of lightning and has a crunching bite. Ferocious though it might be, the Cacodemon is a puff ball when you get your first look at this episode's boss, the colossal *Cyberdemon*.

The architecture of the installations now incorporates teleporters. Fortunately for you, you will also gain access to the plasma rifle. Is there a chance to redeem yourself from the Shores of Hell? You're about to find out.

GENERAL TIPS

The Shores of Hell episode presents you with a new host of challenges, a couple of new monsters, and a whole new set of architectural perils. For this reason, there are a few things you should know before lunging into the first teleporter in your path.

There is still plenty of ooze in this episode, but there are also other areas that are harmful to your life. Oftentimes, these areas may not seem particularly dangerous. It is only by seeing your health being drained that you'll notice something is wrong. Watch out for platforms that appear to be teleporters but are really health drainers. As you explore new areas,

look out for unusual structures, and always approach illuminated platforms, corridors, and walkways with caution.

Because the Shores of Hell uses teleporting booths rather extensively, you should learn a thing or two about them. When you first stand in a teleporter, you never know where you might land. It is only after you've had a chance to connect teleporters mentally that you will know with certainty where each one will take you. As you emerge from a teleporter, you will be blinded for an instant. This presents a good opportunity for your opponents, so our first piece of advice is to always come out firing. Second, if you happen to land in a room or area where you're the focus of attention of a mob of monsters, you can always pull a Houdini and escape via the same teleporter. (However, you have to take a step out of the teleporter in order to activate it again.)

Monsters can teleport too. So keep that in mind. Keep your ears pricked for the swooshing sound that accompanies a teleporter materialization. You may often be followed into a teleporter. A good technique is to wait for your opponent to materialize and blast him when he is most vulnerable.

While you are standing in a teleporter, no monster can materialize in it. This is a good way to keep monsters that are hot on your trail at bay. Further, if you're in the teleporter and a monster is standing where you want to teleport to, go ahead and teleport: teleporting onto a monster kills him. Note that these last two tips apply only to monsters. In Multi-Player mode, other players can kill *you* by teleporting on top of you.

DEIMOS ANOMALY

The first installation in the Shores of Hell is a most appropriate introduction to this episode. You will get to experience plenty of teleporters and become accustomed to their operation. The Deimos Anomaly blends a variety of open areas and more confined spaces in which to do battle. In a sense, you can think of this level as a training ground for the bigger and tougher obstacles ahead.

The Deimos Anomaly is sparse in the secrets department. There are only a couple of secret doors. The doors that give way to remote areas or teleporters are often marked with a skull symbol. There are also a few

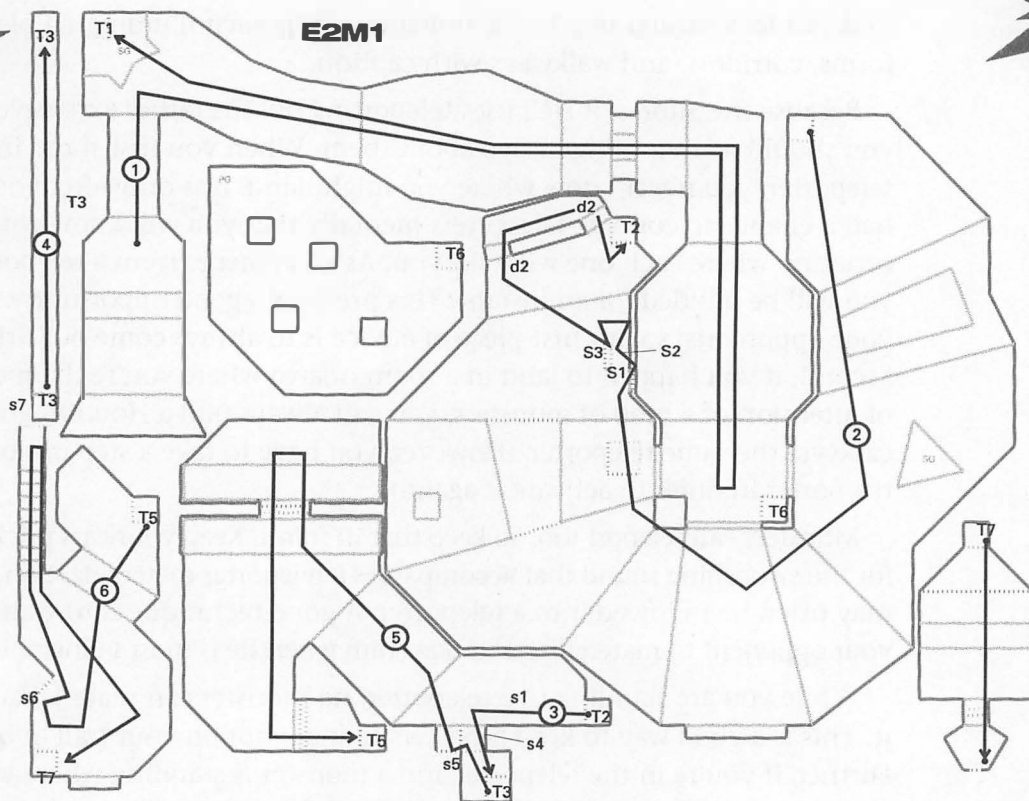

FIGURE 5.1A DEIMOS ANOMALY BLUEPRINTS. *Ideal route map, indicating triggers and switches.*

switches and triggers. Like in the previous episode, switches and triggers will cause certain changes in the architecture. In this level, for instance, there are two switches that cause teleporters to emerge from the ground.

DEIMOS ANOMALY: LIST

In this installation you can find 7 switches, 3 secret doors, 2 triggers, 1 blue security card, 1 red security card, 1 Security Armor, 1 Combat Armor, and 12 teleporters. Besides the shotguns you may pick up from any Former Human Sergeants, the only weapon to be had, but a very good one, is the plasma rifle. You will also be able to fuel up the plasma rifle with a cell charge.

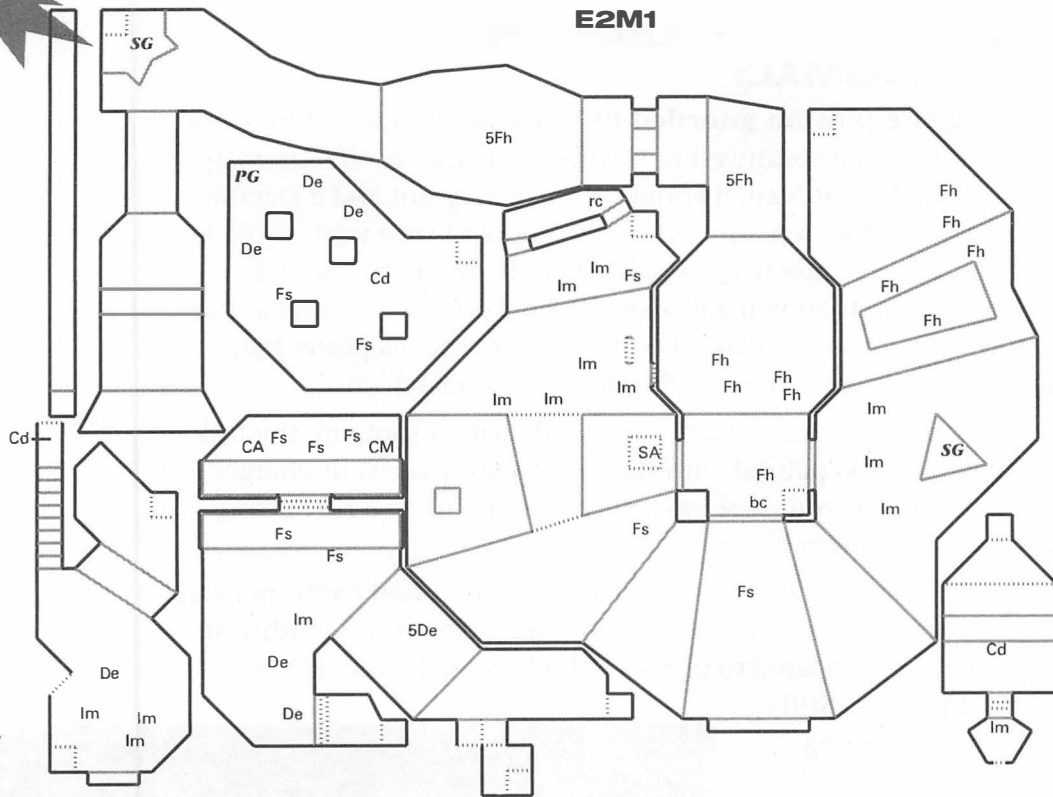

FIGURE 5.1B *DEIMOS ANOMALY BLUEPRINTS. Monsters, weapons, and artifacts map.*

GENERAL STRATEGY FOR THE DEIMOS ANOMALY

Because you will be starting this episode with only a handgun, the first order of business is to arm yourself with a heavier weapon. You will then want to systematically explore the installation to uncover the elusive exit and to pick up all useful artifacts. Rely on the fighting techniques that have gotten you this far. You are on unfamiliar territory, so use caution.

Although there are two security cards in this level, you really only need the blue one to reach the area with the teleporter leading to the exit. So, if you just want to reach the exit as expeditiously as possible, concentrate your efforts on finding the blue security card first.

STEP BY STEP THROUGH THE DEIMOS ANOMALY

Retrieving the plasma guarded by the Cacodemon: When you materialize in the room southwest of the top left corner of the Anomaly, you will be greeted by, at least, a Former Human Sergeant and a Demon. In the harder difficulty levels, you must also contend with what could be your first and last encounter with a Cacodemon. If you are facing a Cacodemon in this room, then you will also be facing one in the room at the southwest corner of the installation (which houses the teleporter that will take you to the final exit from the Deimos Anomaly).

While you can kill a Cacodemon armed only with a shotgun, the task can be made much less painful with the aid of a few plasma discharges. For this reason, it is in your best interest to grab the plasma rifle before dealing with the Cacodemon.

The second you appear on the teleporter, avoid a frontal confrontation with the Cacodemon by running left around the pillar at the southwest end of the room. Be prepared to unload a shell on the Former Human Sergeant lurking there. Still on the run, begin circling northward, along the periphery of the room. Next to the southwest pillar you'll find a cell. Grab it on the run. If a Demon charges you, ignore him as best you can. Don't stop to unload the shotgun. Keep running. Sitting on the northwest corner of the room is the coveted plasma rifle. Grab it, turn around, and squeeze the trigger on the Demon and *then* go for the Cacodemon. (The Demon can move easier around the pillars.) Search for the Cacodemon, and, when you get a good view, release a few more charges and deflate the floating fury.

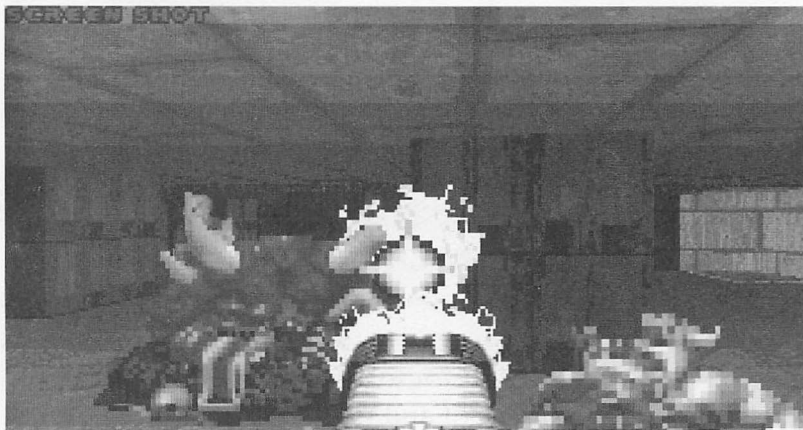

UNCOVERING THE DEIMOS ANOMALY'S SECRETS

Refer to the ideal route map to follow along in our discoveries. Notice, however, that the ideal route completely avoids the room where the plasma rifle can be had.

Following path 1, you will go under a narrow gateway that is in the shape of an upside-down cross. Avoid touching its incandescent walls or standing below it for too long; it will hurt you. Going past the cross and turning south into the central room, you will see the blue security card. Grab it.

Upon returning to the northwest corner of the structure, take your first ride on teleporter T1. You will emerge at the north end of the huge semicircular area that is located below the central room and completely surrounds it. Follow path 2. The triangular platform where the shotgun hangs is not a teleporter—it merely looks like one. Not only that, it is also a health drainer. So grab the shotgun while *running* over the platform.

Follow the semicircle as it turns northward. Jump over the ooze and push off again as you grab the Security Armor and shell case on the square platform on the right side of the ooze canal. Just past the canal, you will see the first switch, s1. This switch causes a narrow slab to rise just a few feet north of your location. The slab has a switch on both of its faces. The switch facing the wall, s2, causes the secret doors d2 to open at the north end of the room. Behind these doors you will find a red security card and a Medikit. The switch on the opposing face of the slab, s3, causes teleporter T6 to emerge in the central room. This teleporter leads to the room where the plasma rifle is found.

When you enter the second teleporter, right next to the eastern secret door d2, you will materialize in the room just southwest from the semicircular room. You are now in a seemingly small area. High on top of the wall in front of you, a bunch of reckless Demons are thrashing about. Pick them off from your vantage point. Move out and reach two more switches along the southern wall. Press the first switch to reveal teleporter T3. This switch only works the first time. (If you do not enter the teleporter, you will miss your only chance for access.) Ride this teleporter

to a narrow hallway where you can get a good supply of health potions and Spiritual Armors (path 4).

Upon returning to the initial teleporter T1, exit the enclosed area and activate the second skeleton switch, s5. This switch will cause the high wall to sink into the ground, opening a larger area. At the north end of this newly uncovered area, following path 5, you will find a latch set off by a narrow ooze canal. The latch requires you to use the red security card. Inside you will find a few Former Human Sergeants, a Combat Armor, and a computer map.

A few feet directly south and then east from the red latch, you will find another latch. This one requires you to have the blue security card. Enter the latch and ride the teleporter to the room at the southwest end of the installation. Follow path 6 to the switch along the west wall. Activate this switch to cause a set of stairs to give you access to switch s7 at the top of the narrow corridor at the northwest end of the room. (In the harder levels your progress might be thwarted by a Cacodemon standing guard.) Activate switch s7 to expose the final teleporter in this level. The teleporter will emerge at the southwest corner of the room. Run to the teleporter and see yourself materialize in a small room at the northeast end of the installation. There, simply walk south and trigger the remaining secret door to open. Go below and find the Exit latch. As you open it, you might have to toast another monster or two. Then you are home free.

CONTAINMENT AREA

After the relatively mild introduction to the Shores of Hell afforded by the Deimos Anomaly, now you find yourself in the imposing structure of the Containment Area. Without a good dose of tenacity, you might question your sanity after running around the warehouse-style fittings of the Containment Area and facing the hordes of implacable Imps.

Rectangular in shape, the Containment Area can be divided horizontally into two distinct areas, each offering a multitude of challenges and opportunities for discovery. The top part of this installation is consumed by a warehouse style garrison with countless heavy boxes of unlabeled equipment and parts bearing the UAC emblem. This area makes for a good place to

snipe away at your opponents, but it also lends itself to ambush situations. The room at the northeast end of the building is riddled with surprises; uncovering its secrets is good cause for celebration. But celebrating is not possible if you're dead. So watch out, for any reward you gain here has a price.

The bottom half of the Containment Area might be likened to the cross-section of a motor. Ceilings that pump like pistons (crushing ceilings), convoluted hoselike corridors, and heavy metal textures will make you feel like you're taking a tour inside a rusty 350 Cleveland engine.

CONTAINMENT AREA: LIST

Surprisingly, after the strong showing of teleporters in the previous level, the Containment Area has not a single one. But there are more than enough switches and secret doors to appease even the hard-core secret monger. You can expect to find: 9 switches, 5 secret doors, and 5 triggers. The useful artifacts consist of: 1 Soul Sphere, 1 computer map, 1 Berserk Pack, 3 security cards, and 2 radiation suits. The hidden weapons and ammunition list is also fairly large: 1 backpack, 1 chainsaw, 1 chaingun, 1 plasma rifle, 1 rocket launcher, 1 bulk cell, 2 single rockets, 2 rocket cases, and 2 shell cases.

GENERAL STRATEGY FOR THE CONTAINMENT AREA

To succeed in this level, you must rely on a keen sense of exploration and, at the same time, observe a healthy amount of caution. There are innumerable twists and turns in this level. Sometimes, even with no enemies in sight, the Containment Area will keep you guessing for a long time. Allow yourself the time to explore areas but always give yourself a path to return to safety. To uncover the many secrets of this structure, you should explore every conceivable nook and cranny.

When you first start playing this level, it is always a good idea to save your game as you go and try different options. This way, in case a particular theory or technique fails you, you can always go back in time and change the outcome by opting for a different avenue or action.

E2M2

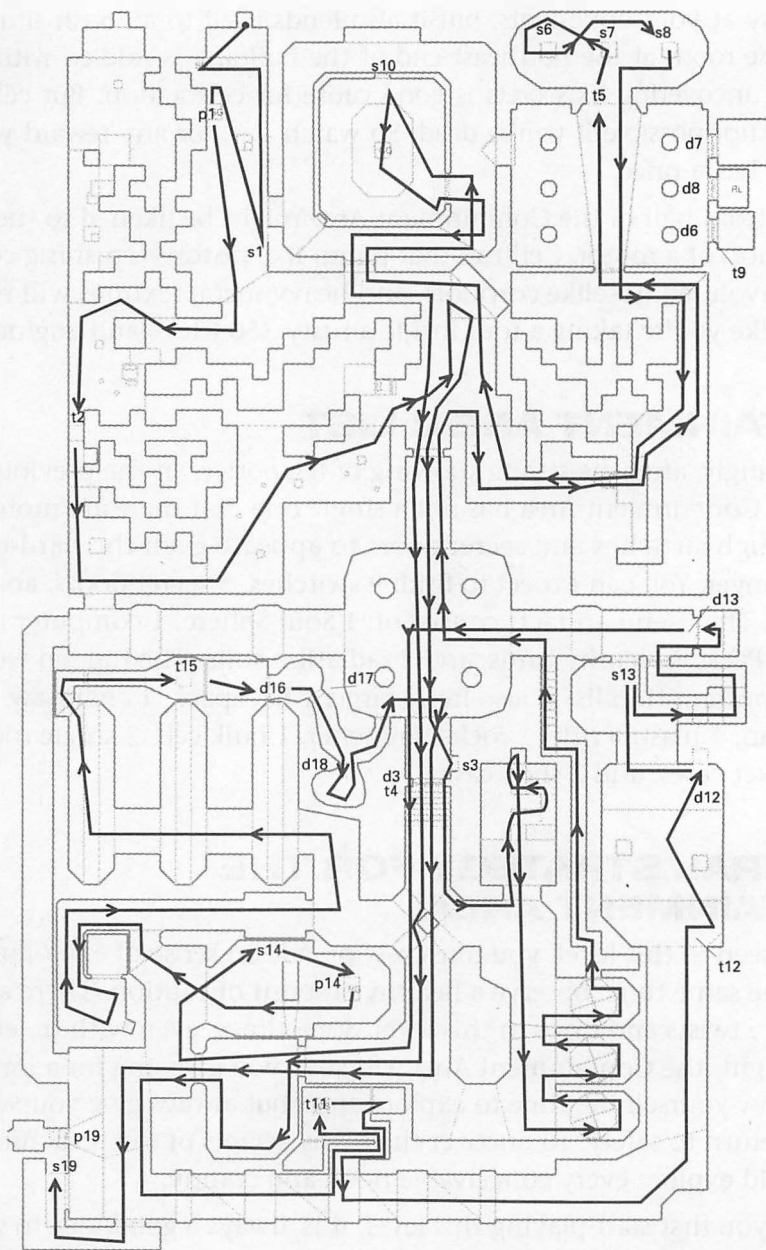

FIGURE 5.2A CONTAINMENT AREA BLUEPRINTS. Ideal route map, indicating triggers and switches.

E2M2

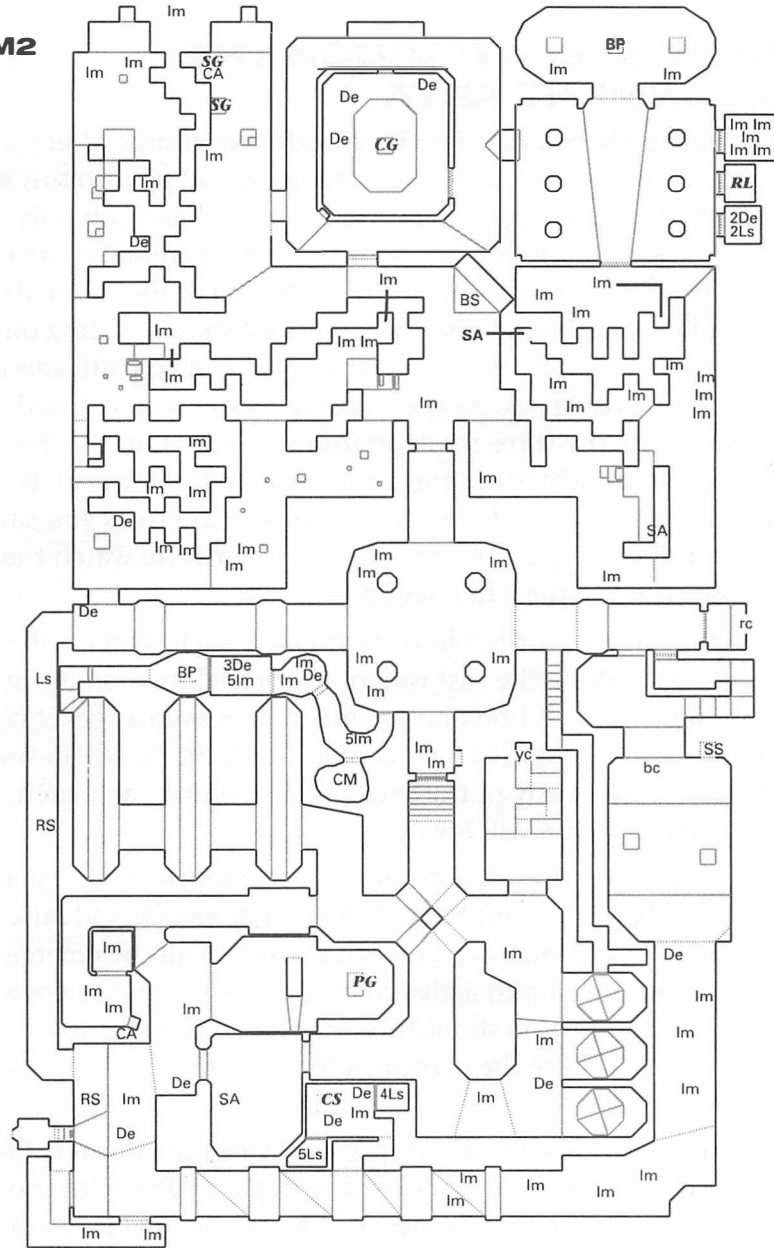

FIGURE 5.2B CONTAINMENT AREA BLUEPRINTS. Monsters, weapons, and artifacts map.

STEP BY STEP THROUGH THE CONTAINMENT AREA

Uncovering the secrets in the northeast room: After you've obtained the yellow security card, open the latch leading into this room. Notice the three latches on the east wall. These latches can only be opened by pressing switches on platforms that are initially sunken in a separate, oblong room partition at the north end of the room. As you walk toward the north end, you will notice a backpack sitting on a square area on the floor. There are two similar sunken platforms on either side of the backpack. As you enter the room, you will activate a trigger that causes the three small platforms to rise from the floor, and they do so very fast. Once up, there is no way to lower the platforms, so you should not simply walk into the room. Run as fast as you can directly toward the backpack. Grab your just reward and watch the platforms finish rising to their full height.

Each platform has a switch in its north face. Each switch will cause one specific door along the east wall of the preceding room to rise. Behind each door you will find ammo and, in one, even a rocket launcher. You will also find a couple of ugly ghouls. Incidentally, whenever you cross the threshold of any of the small rooms behind each latch, the platforms with the switches will lower.

If you think about this for a minute, it becomes clear what your strategy should be. You will want to activate a single switch and raise a single door at a time. In this manner, you can dispose of all the emerging monsters before you move on to activate the next switch and uncover the next room. Of course, you should abstain from entering any of the rooms, as that will cause the platforms to lower, thus making the switches inaccessible.

After activating a switch, and dispensing with the monsters from the room, you should move on to the next switch and deal with the monsters from the next room. Only after you reach the final room in this fashion are you really free to inspect each room and pick up the following items: a rocket case, a rocket launcher, and a shell case.

UNCOVERING THE CONTAINMENT AREA'S SECRETS

Referring to the path outlined in the ideal route, this is how to go about uncovering the Containment Area's many secrets.

A Security Armor and a shotgun are located just a few steps directly south of your starting position and then to the right, next to the UAC boxes. Continuing south, along the wall on your left side, you will find a switch. Activate this switch and a big box behind you will lower to the ground. Grab the box of shells sitting on it. As you continue south along the east wall your path will be blocked by a big crate. But keep walking. A trigger will lower the crate and there you will find two more boxes of shells.

Near the middle of the warehouse area, you will find a darkened corner just east of a yellow latch. A Berserk Pack awaits you there. Turn southward and reach the green central room. Just before the latch at the south end, you will see a skeleton switch on your left. Activate the switch to open the latch. A set of steps will rise as you set off the trigger by taking your first step past the latch. Turn left when you get near the illuminated pillar and enter the small room where the yellow security card awaits. To avoid falling in the red pernicious goo, follow the blue pattern on the ceiling. A platform will form under your feet as you cross the red pit. Grab the key.

Head south to the third, piston-like small room and walk its perimeter to collect the small artifacts and ammo. Go to the next room north, and do the same. When you reach the northernmost room, you must jump on the descending areas and ride a platform down into a small corridor that projects northward from the room. This corridor is littered with health potions. Take them all and go north. You will exit just east of the central green room.

Heading north, reenter the warehouse area and take a sharp right. Your destination is now the northeast room where you can grab a backpack, a rocket launcher, a rocket case, and a shell case. Use the yellow key to enter the room. Head directly north and run for the backpack. Three platforms will rise rapidly as you step inside the room. Each of

these platforms has a switch on its north face. Each switch causes a single latch to open in the room just south, where the booty is kept. Activate one switch at a time. Then run to the large blue room and dispense with any monsters escaping from the small room. When you are done with each room's inhabitants, activate the next switch and start again. Avoid running into any room before all three are open, for the platforms will sink and the switches will be out of reach forever.

After grabbing all the loot, reach the latch in the north central end of the warehouse area. Enter and go right. Open the yellow latch. Inside you'll find a chaingun sitting on a pillar surrounded by a pool of ooze. Activate the switch on the north wall and watch the platform descend as the pool of ooze is covered by a concrete floor. Grab the chainsaw and the ammo and get out.

Once again, head south past the central green room. Go past the illuminated pillar, and run west upon reaching the south end of the corridor. Enter a square room where you can grab a Security Armor.

Upon exiting the room, continue southward as you reach the south end of the installation. Notice that the exit is visible across an unreachable ooze pit. Go east through the crushing ceilings. Time your motion so you start moving while the ceiling reaches bottom. When you reach the second crushing ceiling, veer north and enter a small dark room. Go inside and grab the chainsaw sitting on the blue platform. When you do, a couple of secret doors will give way, releasing a few monsters. Battle them and then exit.

Proceed east, and follow the turn north. (You are now in search of the red security card, which will open and make accessible a crucial switch to bridge the ooze pit near the exit.) As you enter a large room covered with a wide ooze pit in its center, move toward the right corner. You will trip a trigger that causes a Soul Sphere to become accessible at the north end of the room. Dash across the ooze; you only have one chance to grab the sphere.

Then continue north and flip the switch alongside the wall in front of you. This will cause a secret door on the east side to give way and reveal the red security card. Go across the stairs, exit through the blue door, and grab the red security card.

Yet again, go south of the central room, through the room where you picked up the Security Armor, and, upon exiting, turn right. You will enter a small computer room where you will find a rocket and a switch that lowers a platform where the plasma rifle sits. Race to the plasma rifle since you only get one chance to grab it. Exit the room and reach the small room just west of your location. There you will find a Combat Armor. Grab the armor and trace your steps back to the entrance, and then head back east. Take your first left and race west across the narrow alleyways with the blue circular patterns. When you reach the third one, go north. Avoid standing on the blue circular alleyway or your health will start to falter.

When you reach the north end of the alleyway, follow the narrow corridor running east. You will see a backpack sitting on a platform. When you grab it a trigger will unlock a secret door in front. Deal with the onslaught of monsters and continue east. You will run into two consecutive secret doors in the dark metallic monster nests. As the corridor curves southward, you will reach another secret door that is difficult to tell apart from its surroundings. Push against the south end of the bend and you will reach a circular room with a rocket case, a computer map, and a Medikit.

Exit the room and follow the corridor to your right and exit at the southwest end of the green central room. Head back for the southwest corner of the installation. Now you have the key you need and you've picked up a good load of weapons and artifacts.

Go through the red latch and follow the corridor to the switch. Activate it. Then exit and walk across the newly raised platform to reach the exit from the Containment Area.

REFINERY

Simpler in design than the Containment Area, the Refinery is still a bizarre installation, with a good number of secrets and surprises. This structure is a good place to load up on energy cells, for there are quite a few strewn about. The refinery introduces a new construct, square pumping platforms, which completely cover a room. These platforms also appear

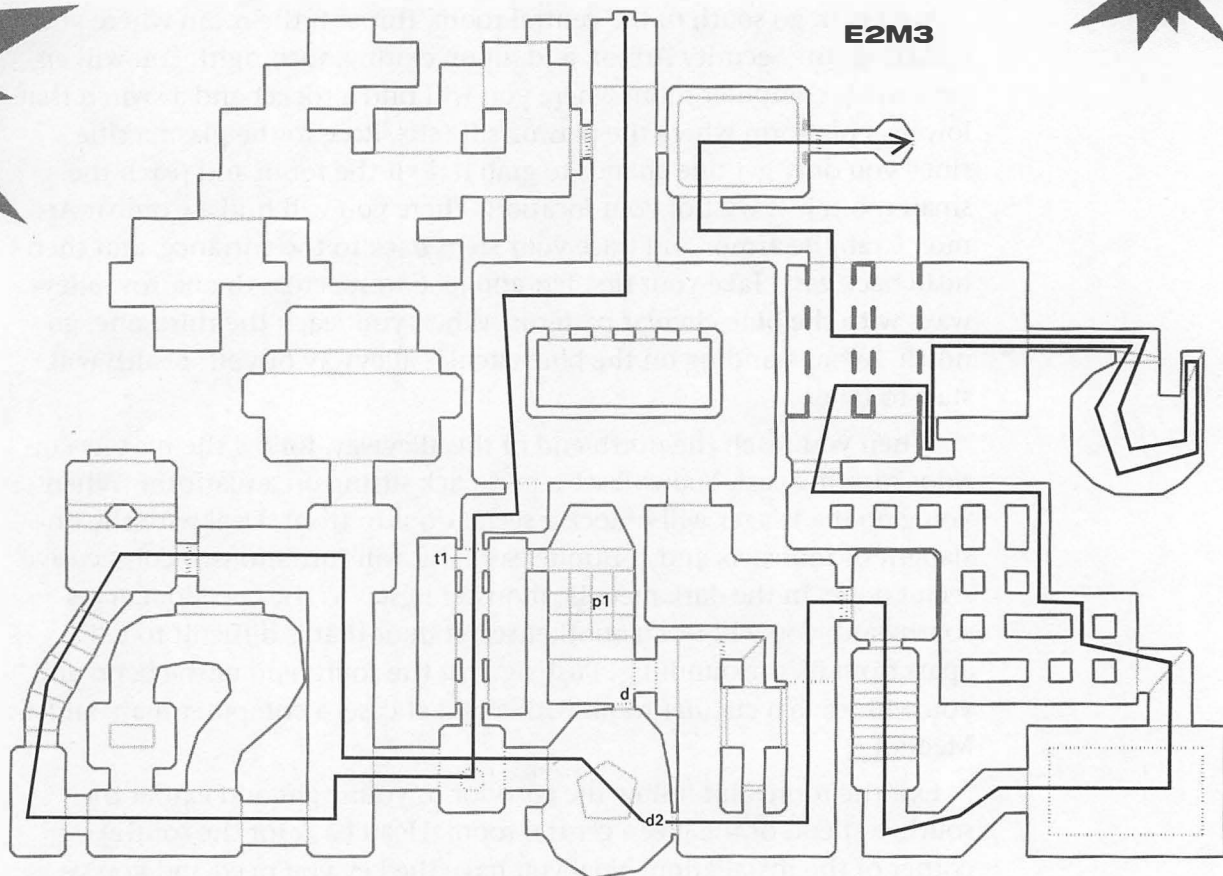

FIGURE 5.3A *REFINERY BLUEPRINTS. Ideal route map, indicating triggers and switches.*

to be alive. Their texture and color is a strange amalgamation of hardware and organic tissue. In this sense, the Refinery begins to blur the line between machine and animal and makes the installation itself assume a distinct character all its own.

As you would expect to find in any industrial installation, the Refinery has its fair share of toxic ooze and harmful goo. And you must inevitably get drenched more than once. To reach the Refinery's exit, you only need to gain possession of the blue security card. Otherwise the entire right wing of this installation remains off-limits. (Incidentally, as you start out in this level, if you can take a peek through the cracks along the eastern wall, you might be able to discern the Exit sign, which is no more than a few yards away.)

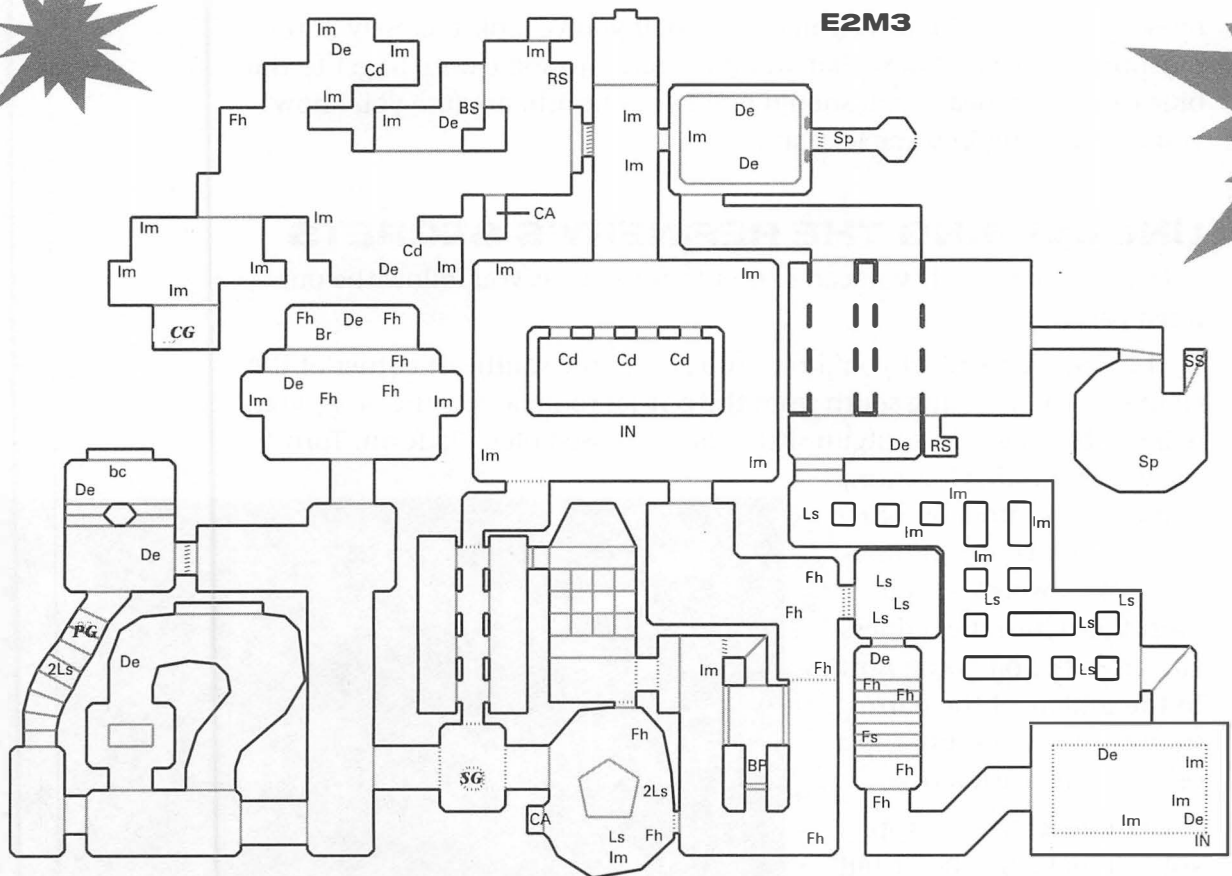

FIGURE 5.3B *REFINERY BLUEPRINTS. Monsters, weapons, and artifacts map.*

REFINERY: LIST

In the Refinery you can expect to find absolutely no switches (with the exception of the exit), but you will definitely run into a number of triggers. The artifacts and weapons you can loot include: 2 Blur artifacts, 1 Security Armor, 1 Combat Armor, 1 radiation suit, 1 Soul Sphere, 1 chaingun, 1 box of rockets, 1 shotgun, 1 plasma rifle, 4 energy cells, and, of course, 1 blue security card.

GENERAL STRATEGY FOR THE REFINERY

Because you must have the blue card to unlock the right wing of the Refinery, where the exit is found, your main concern should be to locate the blue card. As you are well aware, there are quite a few energy cells in this level, and a plasma rifle too. These commodities are hard to come

by, so grab them whenever you can. Also, if you've looked closely at the blueprint map, you know that you must run into some ooze to get to the blue card. This means you should build your health, because you know you'll be wading in some icky stuff.

UNCOVERING THE REFINERY'S SECRETS

Here are the secrets you can expect to uncover as you follow the outlined path.

The first Blur artifact you'll run into is near the southeast corner of the central room. Heading south from the central room across the ooze, you will be able to grab a shotgun sitting on the raised blue platform. Turning west from this location, you will run into a pit of red toxic liquid. However unsavory the prospect is, you must jump into the redness and cross the pit going north. In the middle of the narrow stairway, you will run into a cell and the plasma rifle.

Upon reaching the top, you will have no choice but to jump into the green marble room below. (You cannot climb back into the corridor from whence you jumped into the redness.) This green marble room houses the coveted blue security card and another energy cell.

Exit the room through the latch at the southeast corner of the room. Then trace your steps back into the blue platform and across inside the room with the pentagon-shaped ooze pit. Open the secret door near the southeast corner of this room. You will enter a small courtyard with a heavy walled area in the center where some monsters are kept at bay.

Sticking to the eastern wall of this room and heading north, you will reach the blue door. Push it open, go across the stairs, and follow

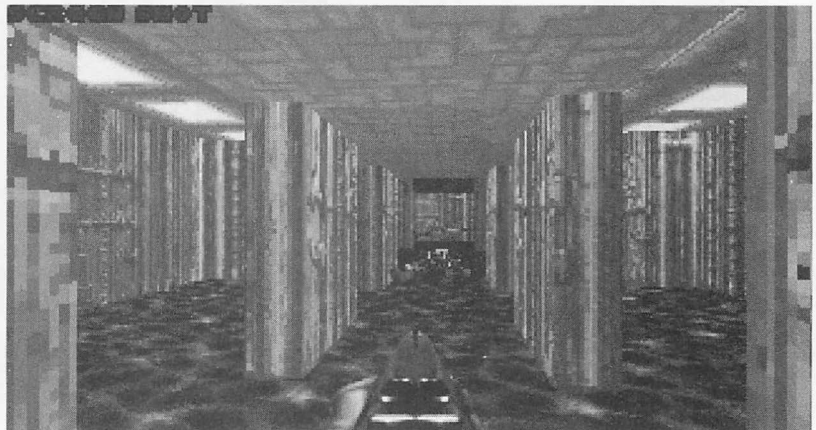

the corridor to the southeast courtyard. There you will find another energy cell, a rocket, and a Blur artifact.

Enter the northeast corridor into a darkened room and follow the east wall in a northwestern direction until you reach the exit from the darkness. Jump into the ooze and run east. Just on the other side of the flanking panel, you will find an indent along the south wall, where you can grab a radiation suit. With the suit on, continue heading east. A small passage in the middle of the eastern wall will lead you to a circular ooze area where you can grab yet another cell and even a Soul Sphere.

Get back on course toward the north end of the rectangular ooze area. Follow the path to another small courtyard. Then run for the exit.

DEIMOS LAB

After experiencing the architectural intricacies of Deimos Lab, you might think the Refinery was only a weekend retreat. Deimos Lab combines just about every major aspect of what makes Doom the challenging and terrifying virtual reality game it is. This level puts you in the middle of an architectural riddle, where triggers, teleporters, crushing ceilings, ooze pits, impact walls, and relentless action seem to come to a climactic head.

Laid out in a roughly square shape, many of Deimos Lab's rooms are interconnected; others require you to take a ride in a teleporter. Uncovering all the secrets in this level requires a great deal of patience and cunning. You can still reach the exit without exploring about 50% of the installation. But if you do it that way, you'll be forever wondering what you've missed.

DEIMOS LAB: LIST

There are many secrets in Deimos Lab, almost too many to mention. But the main ones include: 8 secret doors, 4 switches, 7 triggers, 8 teleporters, 8 platforms, 3 areas of crushing ceilings, and triggered stairs. The major artifacts and weapons include: 3 Security Armors, 1 Combat Armor, 1 Berserk Pack, 1 backpack, 2 radiation suits, 2 Soul Spheres, 2 Blur artifacts, 1 computer map, 1 chaingun, a few single rockets, and some rocket cases.

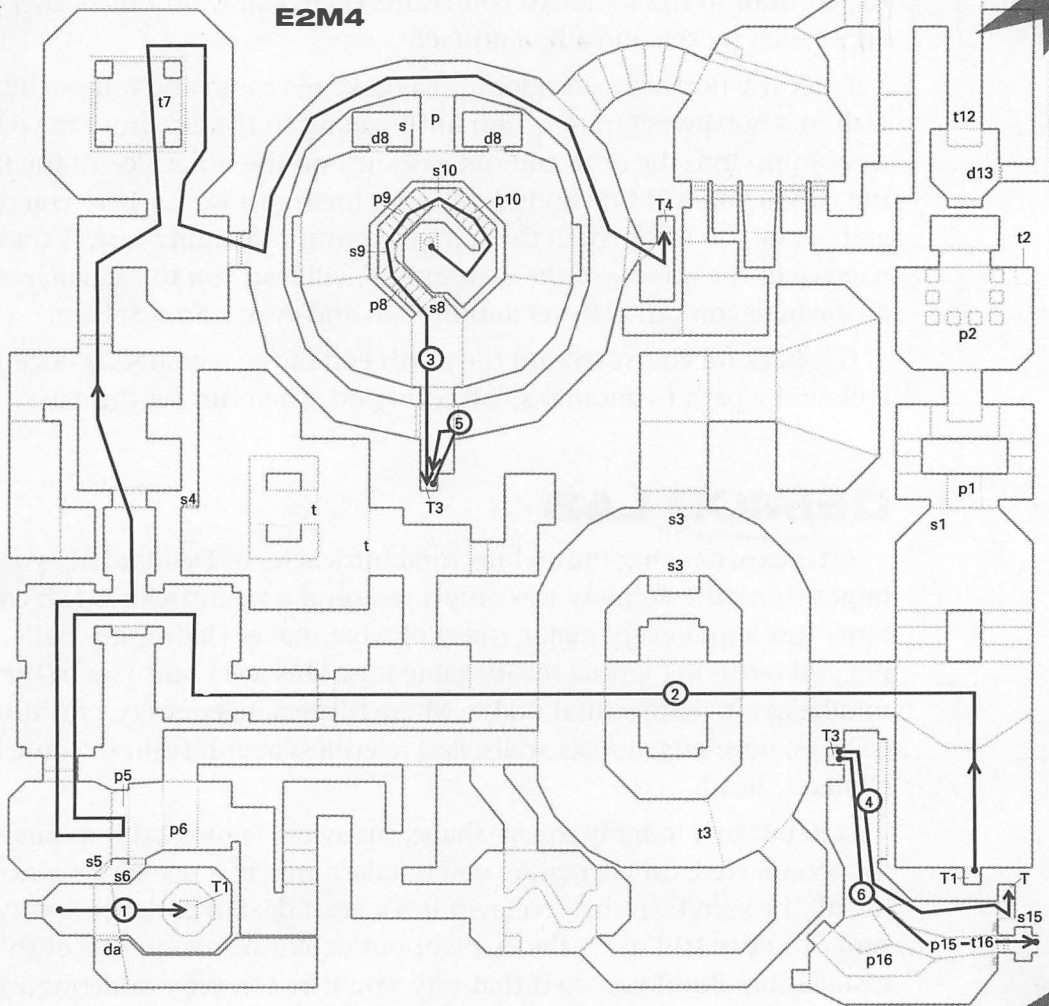

FIGURE 5.4A *DEIMOS LAB BLUEPRINTS.* Ideal route map, indicating triggers and switches.

GENERAL STRATEGY FOR DEIMOS LAB

The exit to this level is found in a confined room at the southeast end of the installation. But the only way to reach this room is via a teleporter. And to reach the teleporter that will transport you to that room, you must go through a couple of latches that require the blue and yellow security cards, respectively. A careful look at the blueprint and ideal

must reach the very center of the circular citadel and set off the trigger that opens the teleporter at the south end of the room. You can either teleport there directly (via the hidden teleporter on the east side of the citadel, accessible only by jumping through a small, cleverly hidden crack on the floor) or you can enter the room and work your way up to its center.

Even when you reach the confined room where the exit is found, your job is not finished. The exit lies across a seemingly unbridgable ooze moat. But surely, if you've made it this far, you can figure out a way to bridge the gap. If not, don't despair; find the answer in the "Step by Step" section below.

STEP BY STEP THROUGH DEIMOS LAB

Reaching the center of the obelisk: There is no way around it. You must reach the center of the circular room to set off the trigger that uncovers teleporter T3, the one that will lead you to the exit room. The center and its trigger are found in an elevated room, up three flights of stairs.

After you have gotten the yellow card, enter the obelisk. Once in the periphery of the obelisk you have two avenues of access:

- Teleport right into its center.
- Or, reach the bottom floor and work your way up to the top.

The first way is by far the easiest. However, you must eventually reach the lower level where you will have to contend with the usual cast of monsters.

Run along the perimeter of the obelisk to the east extreme of its circumference. Look for a small triangular opening on the floor and allow yourself to fall in. You will land in a very tiny area. Push the secret door in front of you and behold the plasma rifle. Grab it. Then head north just a few steps to the awaiting teleporter. In a flash you'll find yourself standing at the very center of the obelisk.

You might be surrounded by a couple of ferocious beasts (especially at the harder levels). But don't despair. You have the plasma rifle. If the

monsters' backs are facing you, shoot them and swallow any guilt you might have about shooting somebody from the back. Step off the triggered platform and off any remaining monsters in the room. As you step off the platform, you will set off the perimeter trigger that causes the key teleporter to materialize on the floor below.

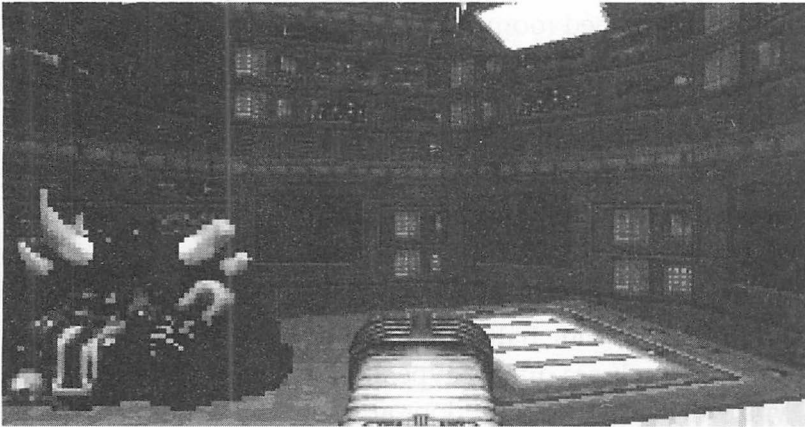

Now you will have to go downstairs. On the way down you will notice a series of switches along your left. These switches simply cause the stairs to form behind you. Don't worry about activating the switches. (You would only need the stairs if you were

making your way up from the lower level.) As you emerge to face the teleporter, a trigger at the threshold will elevate the floors of two doors at the north end of the obelisk and allow a small army of Imps to exit the rooms. They are coming to get *you*. So run straight to the teleporter.

UNCOVERING DEIMOS LAB'S SECRETS

The first secret is found just a few feet from your entry position along the south wall. Look for the place where the flashing light bounces and push the secret door open. Inside you'll find an ammo box, a shotgun, and a shell box. The first teleporter, T1, will transport you to the east side of the Lab. At the far north end of the long room, platform p1 is lowered by switch s1, which is found just west of the platform. The upstairs area contains a number of items blocked by a barrier of pillars. These pillars, p2, are lowered when you cross trigger t2 at the northeast corner of the room. The trigger also raises a secret door behind the pillars, releasing a bunch of Lost Souls. The items behind the pillars include a computer map, a Security Armor, and two Medikits. Behind the secret door there is a box of ammo and a box of shells.

The next trigger, t3, is at the south end of the ooze encircling the small installation just east of the long rectangular room. This trigger causes two secret doors, d3, at the far north end of the ooze canal to open up. These secret doors face each other across the ooze canal. Inside the secret door that faces south, there is a T-shaped room that is very dark and is also populated by a cast of Demons and their close cousins, the Specters. In this area there are many artifacts to be had, including a good number of health potions and Spiritual Armors, as well as a radiation suit, a Soul Sphere, and a couple of Medikits. The other secret door d3, which faces north, is a small recessed area where you can see and grab a Blur artifact and another Security Armor.

The computer room found southwest of the central obelisk contains a good number of installation secrets. Notice the wide hallway between the large computer panels. Both of these panels are impact-type. If you hit the north panel with a bullet, you will cause the secret door at the west end to give way into a dark small room, revealing a Blur artifact, a chaingun, and an ammo box. (It's a good strategy to access this area before setting foot inside the computer room—for the following reason: As you enter this room and cross the west-side threshold, a trigger causes the step behind you to raise several feet, making it impossible for you to leave the area until you have activated skull switch s4 at the west end of the room. If you were to jump inside the room and go inside the hallway, you would cause the crushing ceiling above you to begin a pumping action, squashing anything below it. When you are being chased by a Cacodemon and several Imps inside this area, you should consider running underneath in order to set off the trigger and squash a few monsters.

If you were to hit the south wall with a bullet (before activating the crushing ceiling or impacting the other wall), then you would cause the floor of the central hallway to raise, thus jamming the crushing ceiling mechanism.

The next switch, s5, is at the southeast corner of the southernmost room in the west flank of the Lab. This switch causes platform p5 to lower. Ride the platform to the higher floor and retrieve the blue security card. Once on top, you can activate switch s6 to lower the secret door in front of you and gain access to other useful artifacts. Going in a generally eastern direction, once you make the hairpin turn and are facing

north, you will run into a set of three crushing ceilings, pumping in tandem. Timing your run to coincide with the moment the ceilings begin to rise, you'll be able to reach a narrow zigzag walkway. At the end of this walkway, you will be able to grab a radiation suit, two rockets, a box of shells, and a plasma cell. By jumping into the southwest corner of the room below, you will land upon a Berserk Pack.

Midway up the leftmost flank of the Lab, on the west side, you will run into a latch that opens into a small room where you can get a backpack.

Continuing north along the west wing, you will get to the latch requiring the blue card to open up into a glowing red room. At the far north end, you will see the yellow key sitting in the middle of an incandescent floor. You must run across this area and grab the card. As you set foot on the glowing floor, you will activate the perimeter trigger, t7, which will come crushing down rapidly.

The next installation secret is a platform found at the north side of the obelisk. This platform is activated whenever you step on it, and it takes you inside the obelisk at the bottom floor. On the south end of the central structure inside the obelisk, you will see a small green switch, s8. This switch causes the first flight of stairs to form so you can start climbing to the center, but it also raises the floor of the two rooms to the north, thus allowing some imposing Imps to gain access to the main floor. As you begin climbing the stairs, you will run into two similar switches, each of which builds an additional flight of stairs.

At the very top of the central room, you will see a small square lighted platform on the floor. Running over this platform will cause teleporter T3 to become accessible on the bottom floor, at the south end of the obelisk. The same light fixture that reveals the teleporter is also accessible by taking a shortcut. This shortcut is revealed next.

If you were to follow the circumference of the obelisk, you would find a secret door in the shape of a small triangle at the far east end of the circular building. Falling inside this small crack will place you in front of a secret door. Push the door and enter a small room where you can finally get a heavy weapon, the plasma rifle. North from the rifle's location, you will see teleporter T4. This teleporter will place you smack square in the center of the obelisk.

At the northeast end of the circumference around the obelisk, you will see a path of stairs that curve westward into a small stone patio with a set of five latches in its south side. The first latch leads to a pit of boiling blood. Crossing this gnarly substance, you can climb into a small area where a Combat Armor can be had. (But you must first dispose of some ooze barrels blocking your way. It is easier to blow up the barrels by taking a few shots from the narrow platform before jumping into the blood.)

Two of the doors flanking the main red door in the middle of the small patio contain some big bad monsters that are released whenever you step inside the red door and try to exit. You will inevitably activate a trigger that will open the flanking doors releasing the monsters.

The small blood pit at the north end of the room is flanked by platforms. The first one, found on the west side of the pit, is very small. A couple of Medikits sit on top of it. Going east, you will run into another small platform where a single rocket waits to greet you. Continuing eastbound, you will run into a secret door. Push it open. Facing you will be two corridors. Take the one further east. It will lead you to a small room where you will be able to discern several artifacts even before entering. Do not walk into this room. Run. Fast. Otherwise the trigger you set off, by stepping into the room, will cause the ceiling to come crashing down on you extremely hard. Among the goodies in this room, you will get a couple of single rockets and various Spiritual Armors. You will think you're sealed in. But a narrow wall panel along the east side of this room gives way into a very narrow corridor. Go down the corridor and blow away the swarm of Lost Souls there gathered. You will soon run into another secret door. Push it open and watch yourself emerge on the larger walkway leading to the small cell with the crashing ceiling. Take the westernmost corridor and come out into the small stone patio.

After riding teleporter T3 to reach the exiting room, you will notice the exit is plain to see. You will also notice that a nasty ooze pit makes any attempt to reach the exit unlikely. Notice also that there are two teleporters in this room, besides the one you rode here, and a Soul Sphere that seems as unreachable as the exit itself. There is a way, however, to make two hidden platforms rise up from the pit and bridge the gaps to both the Soul Sphere and the exit.

Jump into the ooze and climb the small platform just north of the exit. There you will see a teleporter, but before rushing in, notice the skeleton switch just south of the teleporter. (This switch was not visible when you stood at the other end of the room, contemplating what to do.) Activate the switch and turn around to see how a platform emerges from the ooze. Still, even though the platform is only a short distance away, it becomes obvious that you cannot reach it. The only thing you can do is ride the teleporter in front of you. Ride it.

You will be transported to the initial teleporter T3 at the south end of the circular room. Now what remains to be done might seem obvious. Step off the teleporter and climb back on immediately. You will reach your starting point in the exiting room. But now you have a platform that bridges the ooze pit. Still it might seem as though there is no way to grab the Soul Sphere. (But there is.) Walk along toward the exit but do not throw the switch to end the level. Rather, notice that as you get near the exit latch, you will activate a trigger which causes a second platform to form and join with the one you now stand on. This second platform takes you directly to the Soul Sphere. Go for the sphere. Then return and throw the switch to exit the level.

COMMAND CENTER

The Command Center has a freeform, capricious layout. It is also the bridge to the secret level. Looking more like a mysterious crop circle than an actual building installation, Command Center has two exits. One takes you to the next installation in the sequence; the other propels you to *the secret level*.

More than anything, this level can be characterized by its propensity for long corridors, which flank three of its sides. There is also an unhealthy amount of ooze. There are only a handful of teleporters in this level, but three of them have a key role in taking you to the secret exit. There are plenty of weapons and ammo in this level, including a plasma rifle and a bulk cell.

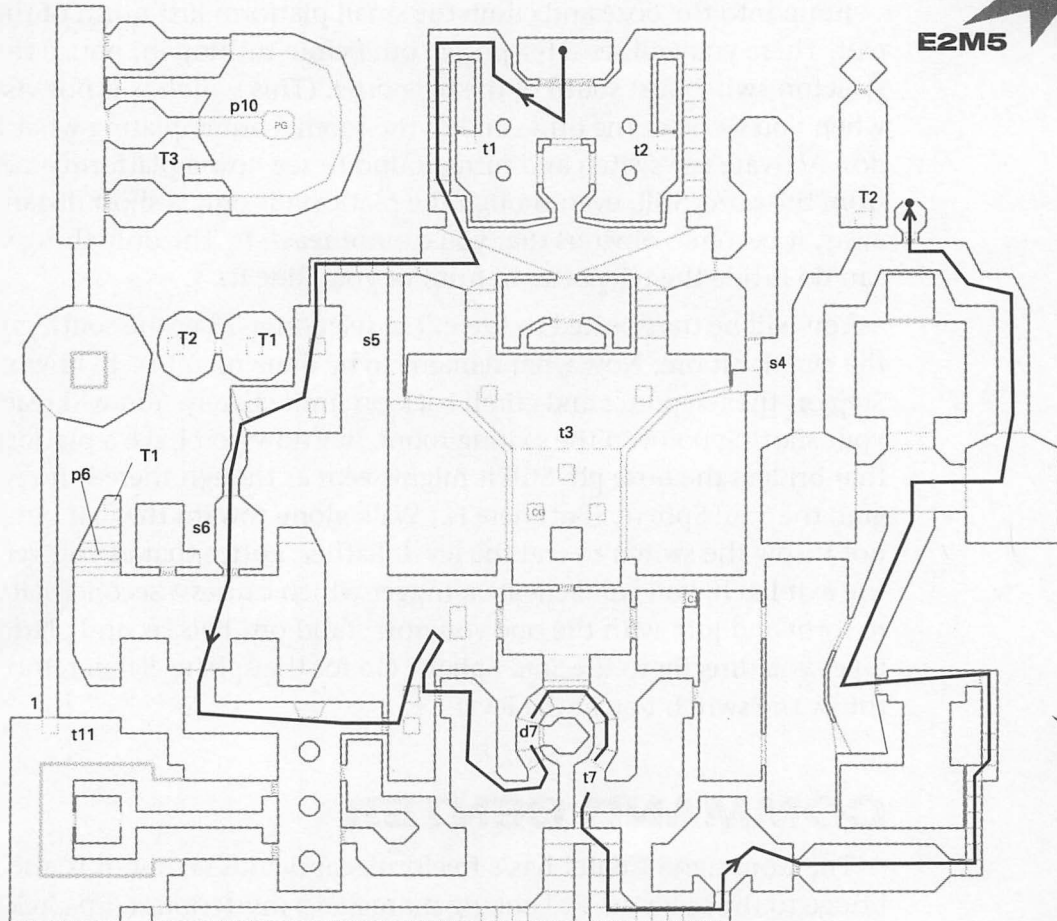

FIGURE 5.5A *COMMAND CENTER BLUEPRINTS. Ideal route map, indicating triggers and switches.*

COMMAND CENTER: LIST

This installation contains 5 triggers, 3 switches, 4 secret doors, 5 platforms, and 4 teleporters. The weapons and heavy ammo to be had include 1 chaingun, 1 chainsaw, 2 rockets, 1 bulk cell, 2 cells, and 1 backpack. The artifacts consist of 1 Combat Armor, 2 Security Armors, 2 radiation suits, 2 Berserk Packs, and 1 Blur artifact.

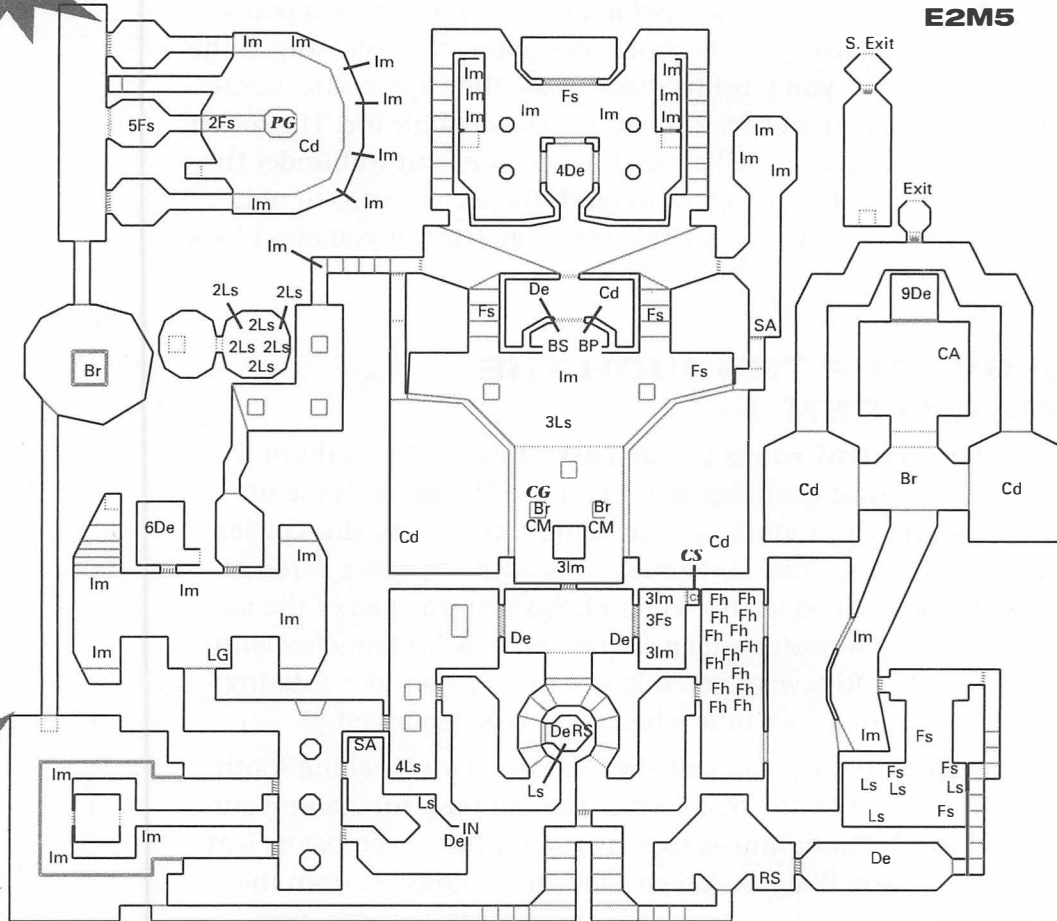

FIGURE 5.5B COMMAND CENTER BLUEPRINTS. Monsters, weapons, and artifacts map.

GENERAL STRATEGY FOR THE COMMAND CENTER

Because there are no security cards in this level, you could simply run all the way to the exit. There are no real physical feats you must execute to reach it. Your basic strategy is then reduced to simply staying alive and overcoming your enemies. And as you move up in the levels for this episode, you are well aware of the mounting pace of the opposition. So you

will do well to stock up on ammo, useful artifacts, and every weapon you can find. You will be facing a wide variety of opponents. Especially at the higher difficulty levels, you must be ready to use the appropriate weapons at the right moment and against the most susceptible foe. The rocket launcher is still best against the Barons. Cacodemons can wilt under the pounding rat-at-tat of the chaingun. To reach the secret exit, you must ride two teleporters. The first may elude you completely if you don't look carefully.

STEP BY STEP THROUGH THE COMMAND CENTER

Looting the central room of the installation: The walls of the middle room are crawling with strange plant life. Packed with useful items and weapons, this room is also crawling with Former Human Sergeants, a band of Imps, some Lost Souls, a Cacodemon, and a Baron of Hell. The strategy outlined in this section helps you reach all of the loot. But you must have a well-stocked chaingun and a rocket launcher with at least five rockets. Otherwise, you might want to reconsider entering the central room until a later time when you are better armed.

As you emerge into the green hallway from the stairs, heading south, you might be accosted by the first Former Human Sergeant coming out of the central room. Shoot him as soon as you see him, even before leaving the corridor. If you like, take down a few more monsters from the safety of the hallway. Unless you are prepared for Armageddon, you should abstain from entering the central room. Instead go for the middle door (with the skull) and push it open. You will be inside a small rectangular room facing a second door. Behind that door is a Berserk Pack, a backpack, and a box of shells. But there is also a Cacodemon, so don't open the door right away. Instead, switch to your chaingun. (If you do not have one, then switch to the rocket launcher. But remember to save five rockets for the Baron.)

Open the door you came in from to give yourself a way to back out as soon as you open the door in front. Push the door where the Cacodemon hides. Open fire with the chaingun and run backwards out the door while keeping your finger on the trigger. Having put away the Cacodemon, get

back in the room and grab the Berserk Pack, backpack, and the box of shells. Get out of the small room and enter the larger central area for an instant, and then back out quickly into the green hallway again. You do not want to stay in the central area very long because you would be ambushed. The best thing to do is to pick off the Lost Souls, Former Humans, and Imps from the relative safety of the hallway, where you can strafe out of the way of incoming projectiles. But look out for monsters emerging from the second door of the central room.

When you've succeeded in clearing most or all of the creatures in this way, enter the room and get your rocket launcher ready. Down the central area of the room, between the two ooze pits, you will see a cell in plain view. You will also notice two pillars, one on each side of an ominous looking enclosure with a face of the Baron of Hell stamped on it. There is a trigger about two feet in front of the cell. This trigger will lower the pillars. The one on the right side contains a chaingun. The one on the left side has the computer map, but it also will reveal a Baron of Hell. Aim the launcher right at the pillar and then take a short step towards the trigger.

As soon as the Baron of Hell can be seen, begin unloading the rockets in rapid succession. The Baron will start to advance toward you. However, if you manage to get five rockets off and hit the Baron five times, he will collapse before he has time to fling an energy charge. Then you can grab the computer map, the chaingun, and any other artifacts of use in this room. Should you miss with your rockets, run back into the hallway, regroup, and try again. If you connected with at least three rockets, a few more shotgun blasts will do the Baron in.

Go back inside the room, pick up any remaining loot, and continue along the path outlined in the ideal route.

Getting the plasma rifle: Although the stop at the northwest corner of Command Center is by no means mandatory—it isn't even along the ideal route—you might feel up to the challenge, especially if you covet the reward. Upon closer inspection of the blueprint and artifact maps, you will notice that the plasma rifle and the bulk cell are found in the center of a large cylindrical structure. Note, too, that platform p10 must be raised to bridge the big gap leading to the items. Switch s10, inside

a small room at the southwest end of Command Center, is the switch that raises the platform.

To activate switch s10, enter either of the latches at the southwest end. You will be entering a straight, narrow walkway walled with crawling vines. (The walkway is also surrounded by ooze, which you will have to cross shortly afterward.) A couple of Imps will attempt to discourage you from reaching the west end of the walkway. Push the door to the small room. Go inside and activate the switch.

Exit the enclosure. You have now caused platform p10 to raise. Your next step is to grab a radiation suit and access the ooze canal leading north. The radiation suit is located in the center of a circular staircase south of the central room. As you climb up the stairs of the circular room, you will notice that the entrance to the small alcove in the middle is blocked off. You must activate trigger t7, found along the last step in the staircase, to cause the secret door behind to raise. So, activate the trigger and trace your steps back to the secret door. Deal with an angry Demon and possibly a Lost Soul or two. Then enter the room and don the radiation suit. Also take the cell and Medikit.

Continue up the stairs. Reach a small latch at the south end. Follow the stairs going west. Jump into the ooze and traverse around the corner. On the northwest end of the ooze there is a secret door that is conveniently marked by a bullet clip floating in the ooze. The door is activated by a small perimeter trigger. Enter the narrow corridor and run north. The ooze ends when you enter a roughly circular room with a Baron of Hell caged in its center. Keep running past the Baron and don't stop until you reach the wider hallway on the north side. If you have 5 rockets or more, bombard the Baron in classic sniper style, using the walls of the hallway for protection from the Baron's energy blasts.

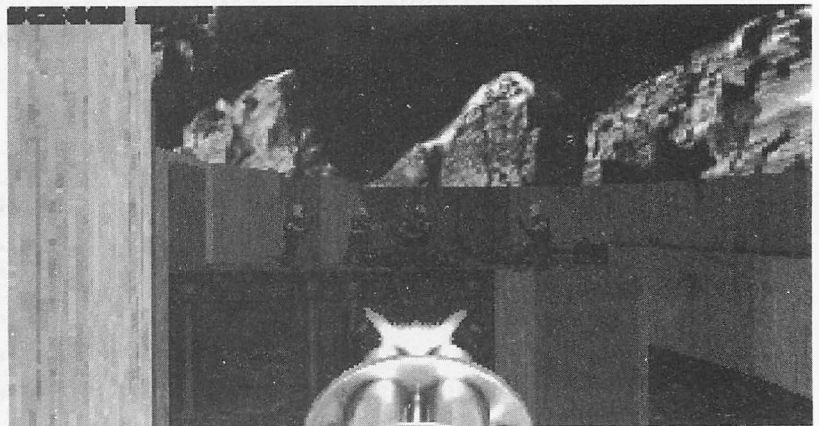

Having disposed of the Baron of Hell, enter the first latch. Greet any waiting Imps and Sergeants with a cocked shotgun. Make your way into the threshold of the cylindrical area. Then snipe away at the Sergeants guarding the plasma rifle as they move toward the center of the cylinder. You will also have to deal with some nasty Imps and, in the harder difficulty levels, even with a Cacodemon or two. Having dealt satisfactorily with the monsters, run around the periphery of the cylinder and pick up every health boost and Spiritual Armor available. Exit through the latch and enter the middle room. Walk confidently up to the plasma rifle and the bulk cell. They're yours. To leave the area, jump into the southwest corner of the ooze. Reach teleporter T3 and see yourself emerge back in the starting place for the level.

UNCOVERING THE COMMAND CENTER'S SECRETS

Triggers t1 and t2 open secret doors d1 and d2 respectively. Behind each door expect to find a few Imps and a box of shells. The central latch in the green hallway, just south of your entry point, takes you to another secret door. Inside you will find a Berserk Pack, a backpack, and a box of shells.

Trigger t3 is found in front of the cell inside the central, green room. The trigger causes two pillars in front of you to lower. The pillar on the right side lowers a chaingun; the one on the left, a computer map (and, in the harder difficulty levels, a Baron of Hell).

The small ledges along the north side of each ooze pit in the green room lead to narrow passageways. You can drop into these narrow passageways. The one on the east side takes you to a secret door you can push to get at a Security Armor and some Stimpacks. But the narrow, greenish room is also inhabited by Imps.

The narrow passageway on the east side of the green room drops you into a similar area where you will ride a platform and emerge into the narrow stairway west of the green hallway.

The H-shaped room near the southwest end contains a couple of secrets. The first one is a switch s6, found behind the latch just west of your entry place into this room. The switch is guarded by ferocious

Demons. Activating switch s6 causes a series of steps to form at the northwest corner of the H-shaped room. These stairs lead to what appears to be a bloody wall. But stepping inside, you will find yourself in front of teleporter T1. This teleporter will take you to the dumbbell-looking structure north of the H-shaped room. You will be surrounded by Lost Souls. (The best way to dispose of them is to unload plasma cells or bullets while spinning as fast as you can, all the while remaining on the teleporter.)

Pushing the secret door at the west end of this circular room, you will gain access to a similar room with another teleporter in its center, T2. Ride this teleporter to the bottle-like encasement at the northeast end of this installation. This is the exit to the secret level.

The southwest end of Command Center is home to various other secrets. Switch s10, inside a small square room at the southwest corner, causes platform p10 to rise from the bottom of the huge ooze pit at the northwest end. The platform allows you to grab the plasma rifle and bulk cell in the middle. Trigger t11 is found just south of the long west-side corridor leading to the circular room where the Baron of Hell is caged. This perimeter trigger simply activates secret door d11 so you can continue making your way north.

In the northwest area you will find not only the plasma rifle and the bulk cell, but also a Berserk Pack and another teleporter, T3. To reach either of these, you must dive into the ooze below. The Berserk Pack is down a narrow path along the northwest side of the ooze pit. Teleporter T3 is just opposite, on the southwest side. It transports you to your initial entry point into the Command Center.

Another trigger is found just south of the central green room. The trigger in front of the Medikit along the south wall of the room will cause the door to the east side to open and release a bunch of Imps and Demons with really bad intentions. Inside that room, at the far northeast corner, you can push a secret door to uncover a chainsaw.

Along the circular staircase there is a secret door in the west side of the staircase. That secret door opens into a small alcove where you can grab an energy cell, a radiation suit, and a Medikit. But not without fighting off a Lost Soul and a Demon. The secret door, however, will not open until

you have activated the trigger at the south end of the stairs. The room east of the circular staircase houses a great many Former Humans. But that room also contains a valuable box of rockets. Southeast of the circular staircase room, the narrow stairway leads to a small room just carpeted with health potions and Spiritual Armors. But most importantly, along the southeast wall, you will find a radiation suit. Entering the latch east of this room will take you to an ooze corridor where a Demon will prey on you. Emerging from the ooze, you will come to the remaining area of the installation, which is roughly bell-shaped. Upon setting foot in it, you will attract the attention of some very curious Cacodemons. You will be able to discern a Combat Armor directly north. If you head for it, you will activate a trigger that will cause the lights to dim. If you continue forth, another trigger, t9, will cause the secret door in front of you to open and unleash a bunch of Demons.

HALLS OF THE DAMNED

After playing this level for a while, you will get a true appreciation for its name. Much like its predecessor, an aerial view of Halls of the Damned reveals a weird, ancient hieroglyphic, or perhaps the schematic to a Demonic time machine. If you look at its structure long enough, you might begin to see recognizable shapes. Some claim to see a smiling cat (on the right side of the installation), others, the Virgin Mary. But regardless of anything you think you see, one thing is for real: this level kicks butt. Or to be perfectly blunt, in spite of the imminent threat of evisceration, Halls of the Damned offers some delightful vistas. Its lines are sleek and sexy. Its secrets are puzzling yet strangely alluring. This installation is heavily geometrical and oddly asymmetrical.

HALLS OF THE DAMNED: LIST

This installation contains 7 switches, 13 triggers, 15 secret doors, 1 crushing ceiling, and 1 dropping floor. The weapons and ammo include 1 chainsaw, 1 rocket launcher, 1 plasma rifle, 2 rocket boxes, 5 single rockets, 4 cells, and 1 backpack. Other useful items include 1 Combat Armor, 2 Security Armors, 2 Soul Spheres, 3 Blur artifacts, 1 Berserk Pack, 2 light amplification goggles, 1 computer map, and all 3 skeleton keys.

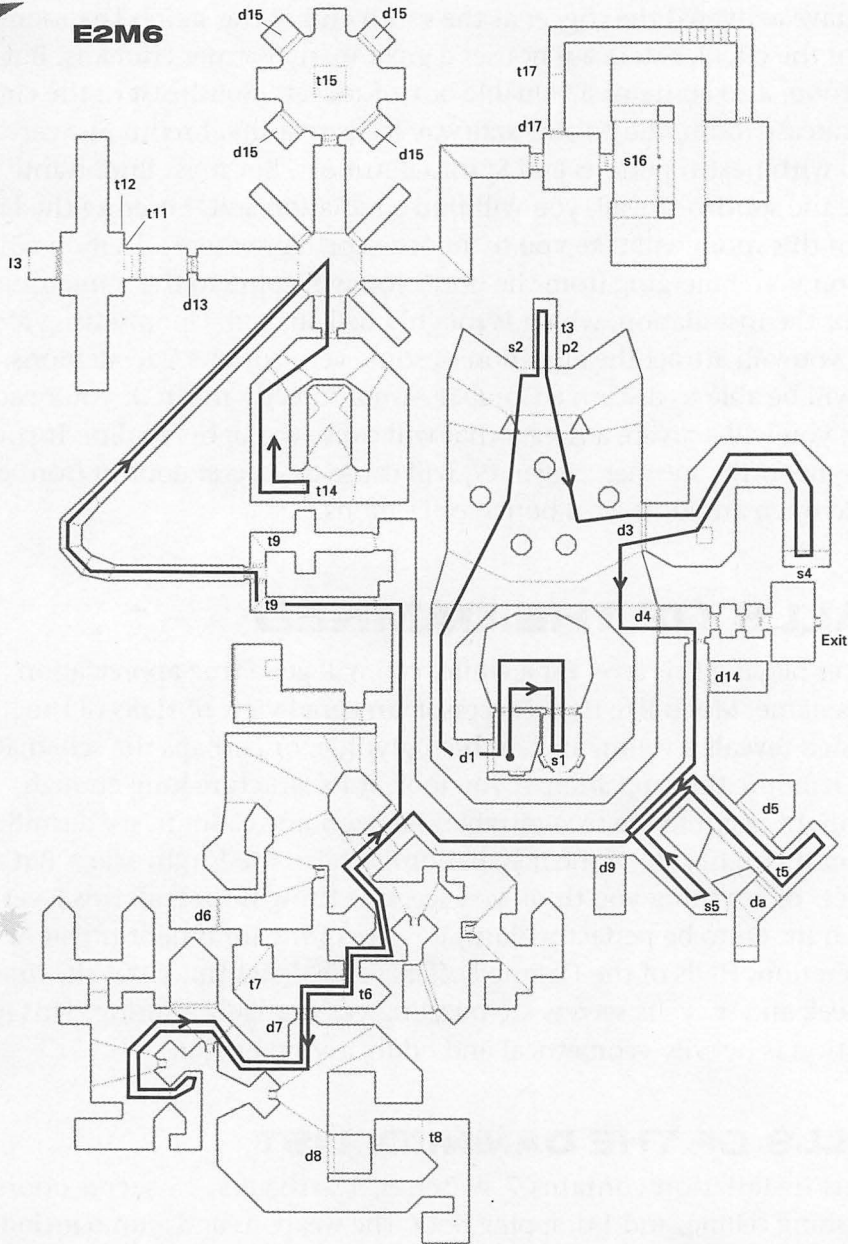

FIGURE 5.6A HALLS OF THE DAMNED BLUEPRINTS. Ideal route map, indicating triggers and switches.

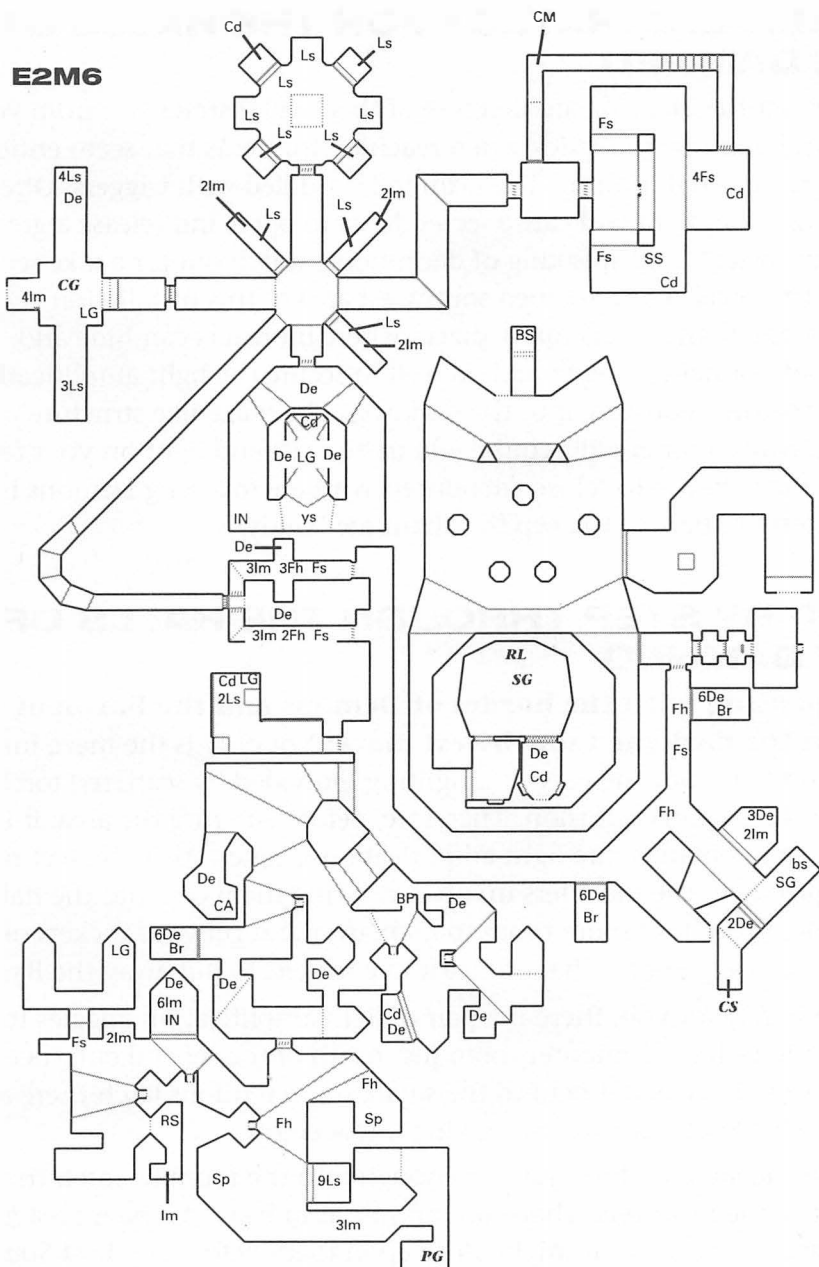

FIGURE 5.6B HALLS OF THE DAMNED BLUEPRINTS. Monsters, weapons, and artifacts map.

GENERAL STRATEGY FOR THE HALLS OF THE DAMNED

Don't let the dizzying architecture of this level distract you from your goal. And don't be too quick when reaching for items that seem enticing if they're not vital. Halls of The Damned is riddled with triggers. Often, reaching for an item will cause secret doors to open and release a great many monsters. And speaking of deceptions, watch out for a fake secret exit in this level. The darkened southwest area of this installation is rather angular and offers many places where monsters can hide and come out pouncing. You would do well to secure the light amplification goggles before venturing into the darkness. The maze-like structure in the southwest corner will require you to be swift and light on your feet. Because the chance for close encounters with encroaching Demons is rather certain, be sure to keep the chainsaw handy.

STEP BY STEP THROUGH THE HALLS OF THE DAMNED

Dispensing with the hordes of Demons and the Baron of Hell in the darkened southwest maze: Not only is the maze intrinsically difficult, but the very dim lighting, provided by scattered torches, adds to the overall confusion. Therefore, before entering the area, it is a good idea to obtain some light amplification goggles. Also, the technique for disposing of the monsters involves drawing them out into the hallway where you have more room to maneuver and get your rockets off. (As you know, you must have at least five rockets to put away the Baron.)

Fortunately for you, there is a pair of light amplification goggles to be had in the L-shape computer room just north of the second entrance to the darkened maze. But behind the small, unpretentious latch there are various Lost Souls and an unforgiving Cacodemon.

Open the latch and run just far enough into the room to catch the attention of the monsters. Then run out just as quickly. As the monsters are drawn to the latch, it might close upon them before any Lost Soul can exit. Open the latch again, and sidestep or pull back as you pull the trigger of the shotgun. Continue taking shots in sniper fashion, opening the latch to get a view of your targets and then pulling back again. After

taking care of the Lost Souls, the Cacodemon will be next. Switch to your chaingun. Stand right in front of the door, open it and sink your finger on the trigger. While this maneuver may seem rather daring, you will have the upper hand if you can connect before the Cacodemon has a chance to belch a ball-lightning. Once you deflate the Cacodemon, run into the room and retrieve every useful item. You will find the light amplification goggles around the computer console along the east wall of the room.

Now, with the benefit of light amplification, go face the music in the darkened area. If you require additional armor, take the first darkened entrance (just south of the computer room). Then head west. When you reach the wall, look to your left (south) and retrieve the armor. Go back and around to continue heading south in the maze. (On your way south, you will notice the secret door in the west wall, behind which the small army of Demons and the Baron of Hell lie in wait.) When you reach the south wall, look east and notice the single rocket and other items by the small latch (which opens into the southernmost end of the installation). Grab all the items and run over trigger t6. That trigger will cause the secret door you passed to open. Don't hang out too long. It may take the monsters a precious few seconds to notice your presence. So make a speedy exit to the hall. As soon as you reach the hallway, turn around and get in a good position to pick off the emerging Demons.

The Baron of Hell will join the Demons shortly. Begin to back away

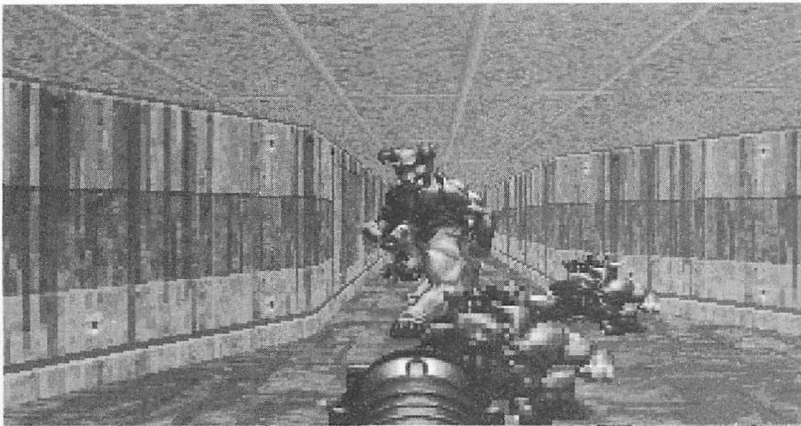

heading northeast as you continue firing with the Baron in pursuit. When you get a good angle on the Baron unload your first rocket. Sidestep to either side of the narrow hallway to avoid the Baron's energy charges. Maintain a safe distance and let go more rockets, being careful to take good aim and avoid hitting the nearby wall. Unload the fifth rocket, and watch the Baron fold.

UNCOVERING THE SECRETS OF THE HALLS OF THE DAMNED

Skull switch s1, found in the small room east of your entry point opens secret door d1 in the initial room, giving you access to the outside corridor. Switch s2, at the north end of the catlike structure, raises staircase p2 from the small rectangular ooze pit. This allows you to reach the Berserk Pack.

As you reach for it, you will cross trigger t3. This trigger causes the large stone area south of you to turn into slime. At the same time, the trigger also opens a secret door along the east side of the newly formed pool. Follow the wide ooze canal to its end. (Along the way you can jump on a platform and use the Medikits resting there.)

At the end of the ooze canal there is another small platform with switch s4 in plain view. Activate s4 to cause secret door d4 to open up just south of the secret door that you entered.

Trigger t5, at the end of the southeast corner of the hallway (leading to the blue skeleton key), causes secret doors d5 to open and release a few mad Demons and Imps. One of these doors is north of the trigger, the other, just south. You should avoid setting off this trigger. Switch s5, found on the parallel hallway, also activates the same secret doors. But this second hallway puts a heavy wall between you and the monsters. The wall has a large horizontal slot where you can systematically snipe away at your enemies. Another secret door, da, right behind the southern d5, leads you to a chainsaw.

The next trigger, t6, is found just east of the latch that opens into the southwest area of the installation. Trigger t6 raises secret door d6, where a rocket can be found. However, you will be releasing various Demons and, in the harder difficulty levels, a Baron of Hell as well. Trigger t7 is just west of t6. That trigger causes the latch between the triggers to open and become accessible to the monsters inside. The red skeleton key is located at the very southwest corner of Halls of the Damned. Trigger t8 is found in the eastern side of this same area. You will be enticed to enter

this area to grab the various items and trip the trigger. As a consequence, secret door d8 will open, releasing those fearsome flying Lost Souls. Behind that door, a single cell can be found.

The next set of triggers, t9 (there are two), are found, respectively, at the northwest and southwest corners of the narrow hallways left of the catlike structure's smiling mouth (formed by four pillars). Both of these triggers cause secret door d9 to open at the southeast corner (just east of the hallway leading to switch s5). This door sets another nasty Baron free.

Switch s10 is found inside the tiny space leading to the 45-degree hallway. Pushing this switch causes the latch to open, revealing the long, gray hallway with stairs. Eastward from the crucible-like structure, a latch opens into a room where triggers t11 and t12 lie parallel in close proximity. As you begin to move into the wider space, trigger t11 causes the crushing ceiling above you to come crashing down. A step in front of trigger t12 causes secret door d12 along the west wall to give way and release an assortment of monsters.

Switch s13, behind d12, causes the entrance to this wing to open, allowing you to time your run back to the crucible underneath the pumping, crushing ceiling.

The south "spoke" of the crucible leads to the vine-covered room that looks barnlike on the map. Twin triggers t14, at its southern side, cause the small secret door d14 to rise, releasing yet another Baron of Hell. Between the triggers you will find the yellow skeleton key.

The north spoke of the crucible takes you to a circular room with a platform at its center and various latches in its circumference. The latches will open the second you climb the central platform to grab the Security Armor, cell, Medikit, and Blur artifact. Lost Souls will then come swooping down on you from every angle.

The eastern spoke of the crucible takes a couple of 90-degree turns into a small latch. Behind the latch you will find the much-sought exit sign in a quiet, blue room. But beware, for this is a deception. The switch, s16, will cause the floor below you to drop, making you the center of attention of a large contingent of Former Human Sergeants and a Cacodemon. A Soul Sphere floats near the south end of the rectangular room.

The final trigger in this level, t17, is found across the narrow walkway leading back to the small area east of the blue room. This trigger simply opens secret door d17 so you can access this small area.

The true exit to this level is found east of d4 (along the midsection of the catlike structure). To access the exit, you must go past three consecutive latches, each of which requires one skeleton key to let you pass through.

SPAWNING VATS

Roughly rectangular in shape, Spawning Vats is broken into a great many compartments that fit together like the electronic components in some puzzle-like computer card. As you begin a potentially lethal tour of this installation, you will be impressed by the wide variety of architectural styles throughout its many rooms, from the highly metallic, sterile feel of a computerized enclosure, to a bare courtyard paved with heavy stone. Other more capricious shapes seem to serve no function to their form. A particularly impressive decor is that of a room that appears to be a place of worship and sacrifice for some alien, pagan religion.

SPAWNING VATS: LIST

There are 9 switches, 1 trigger, 7 secret doors, and 3 platforms in this level. The weapons and ammo include 1 chaingun, 1 rocket launcher, 1 plasma rifle, 1 chainsaw, 3 cells, 2 rockets, 2 bulk cells, 1 backpack, and 1 Berserk Pack. The artifacts consist of 1 invisibility Blur, 2 Invulnerability artifacts, 1 Soul Sphere, and 1 Combat Armor. In addition, all 3 of the security cards can be found and are necessary to reach this level's exit.

GENERAL STRATEGY FOR THE SPAWNING VATS

Even the shortest route to reach the exit requires you to possess all three security cards. Besides staying alive, this makes getting the cards your top priority. Also, if you reached this level equipped with some heavy artillery, you will need it very soon. The key to surviving Spawning Vats is taking a few chances. There are strategically placed weapons, ammo, and artifacts

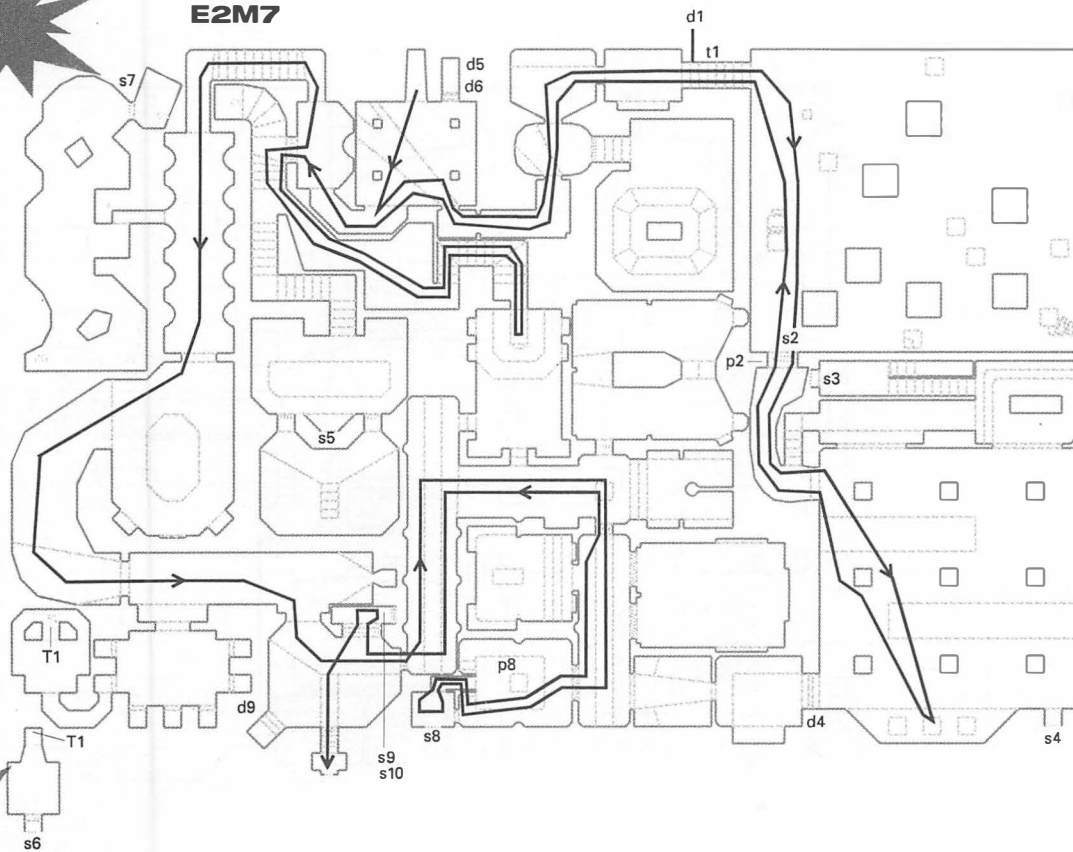

FIGURE 5.7A SPAWNING VATS BLUEPRINTS. *Ideal route map, indicating triggers and switches.*

in this level. You must know when to make a run for the key Invulnerability artifact, which can save your life and give you a chance to return fire even in the most unfavorable situations.

Pick up every rocket, cell, and bulk cell you can find along the way. You will be confronting a good number of Imps, Cacodemons, Demons and a terrifying Baron of Hell.

STEP BY STEP THROUGH THE SPAWNING VATS

Offing the Demons in the warehouse room: If you follow the ideal route, your first challenge awaits you in the warehouse, at the

E2M7

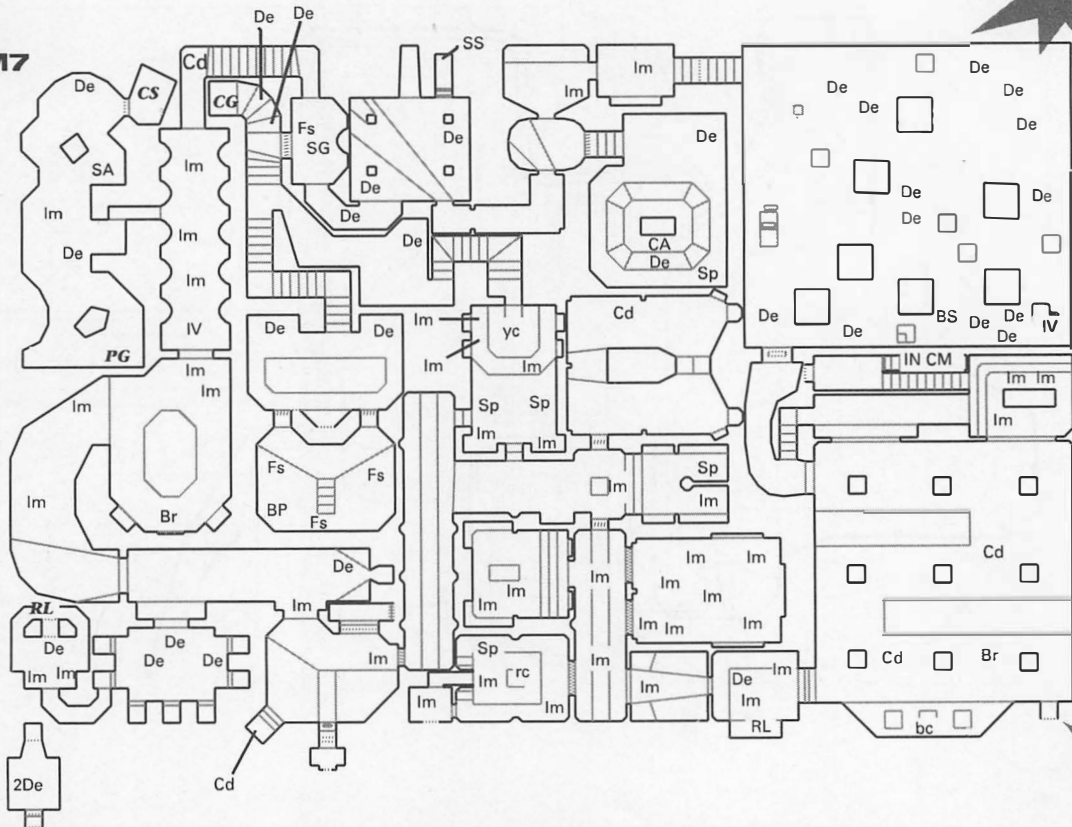

FIGURE 5.7B SPAWNING VATS BLUEPRINTS. Monsters, weapons, and artifacts map.

northeast corner of the installation, where angry, voracious Demons want to have you over for dinner. Although your flesh is in danger of being torn from your bones in this room, there is an Invulnerability artifact at the southeast corner. There is also a Berserk Pack. This means that even if you sustain some serious damage, you can always reach for the Berserk Pack and get completely well again. If you can grab the Invulnerability artifact as quickly as possible after entering the warehouse, you will also be able to defeat the monsters with your bare hands. But you only have 60 seconds in which to do it.

Also, straight south from the entry to the warehouse, you will find a group of crates on which you can climb to escape the vicious bites of the Demons.

Once you cross the trigger in the middle of the stairs descending into the warehouse, a secret door behind you will shut you off, forcing you to deal with the situation just below. So you might want to avoid crossing the trigger halfway down the stairs. Instead, wait for wandering Demons and pelt them as soon as you see their bouncing pink bodies. After crossing the trigger, a few more stray Demons may come charging your way. Since there is not much room to back up, you might want to resort to the chainsaw (if you have one handy). Otherwise, blast the attacking Demons with a chaingun or the shotgun.

Since you cannot hold your position indefinitely, you must go down into the warehouse. If you have a few rockets to spare, you might want to step just inside and unload a couple of them, taking advantage of the wide angle and space at your disposal. Then switch to the chaingun and look directly south. Run full-steam toward the small group of crates ahead. If you are confronted on your run, trust your chaingun to help you get through. Climb the smaller crates and reach the top of the bigger crate, where you get a fresh case of shells. You can then unload a couple more rockets, if you can afford them, from this vantage point. Then thin out the Demon overpopulation a little by taking good aim with your shotgun.

When you've disposed of most of the Demons, jump down and make quick work of any pinkies left. Then proceed to grab all the ammo and artifacts found in this room.

Overcoming the Baron of Hell at the west end: The west wing of Spawning Vats is home to a couple of cruel Cacodemons, a few Imp malcontents, and an unforgiving Baron of Hell. To penetrate this impressive wall of adversaries, you must expose yourself and risk a lot. And, also, you must have a good supply of rockets. At the very least, a minimum of five. You must also move very fast and execute all your moves smoothly.

When you reach the bottom of the staircase leading to the silver metal room, do not go in all the way. First attempt to thin out the Imps and kill the Cacodemon. In the room south of the metallic area, the Baron of Hell awaits. You will want to keep the Baron from noticing you before you've had a chance to dispose of at least a few Imps. If you can spare a

couple of rockets, hit the Cacodemon and Imps from the threshold. If you can't afford the rockets, spray your chaingun nonstop until you deflate the Cacodemon and put away as many Imps as possible.

Before the Baron has had the opportunity to reach the metal room, run straight south for the Invulnerability artifact. You might actually run head on into the Baron as you reach for the artifact. Do not fear. When you grab the artifact, you are impervious to any attacks for a few seconds. So make the most of them. Begin to unload your remaining rockets on the Baron. Do not worry about being too close to a wall. You are invulnerable. You can pound the Baron with rockets even while standing right in front of him. If you require more space, head south into the strange ceremonial-looking room and pick off your target from a more comfortable distance.

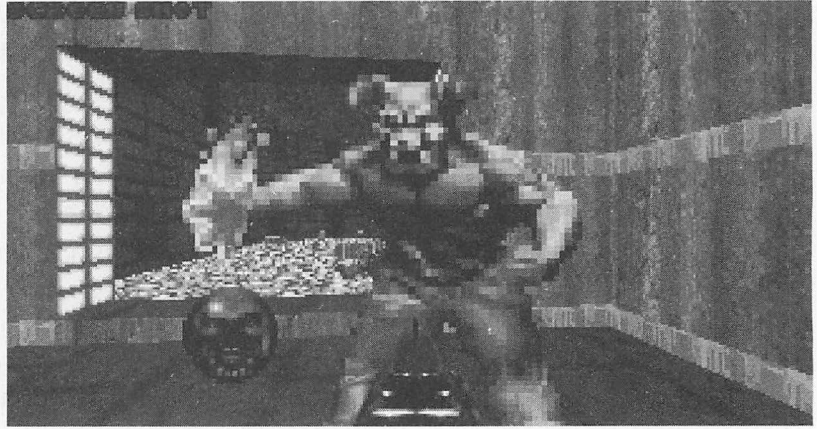

UNCOVERING THE SECRETS OF THE SPAWNING VATS

The first trigger, t1, halfway down the stairs leading to the big warehouse room on the northeast corner, causes the door behind you to close for 30 seconds. Inside the warehouse room, you will run into piles of Demon flesh. Scattered about, you will find a Berserk Pack, a case of shells on top of some crates, a single cell, a rocket, and an Invulnerability artifact. At the southwest corner of the warehouse room is switch s2. This switch lowers a platform so you can access the hall leading to the south courtyard with the parallel ooze pits. The blue card is at the south end of the courtyard. Switch s3 is located at the west end of a narrow hallway

north of the courtyard. Switch s3 activates the small latch across the way. Behind d3 you will find an ammo box and an invisibility Blur.

Switch s4 is at the southeast corner of the courtyard. Activate this switch to open secret door d4 at the opposite end. This door gives you access to a room where a bulk cell awaits sitting atop a narrow platform.

The yellow card is found on a narrow walkway at the end of a set of stairs southeast of your initial entry position. To get to the yellow card, you must go through the latch west of the initial room (which you can only open with the blue card). Then you must go southwest and eventually reach the stairs that lead to the narrow walkway. Incidentally, if you go north on the stairs after reaching the blue latch, you will find a chain-gun at the very top.

Switch s5 is found in the center of the room southeast of the walkway where the yellow card was found. This switch causes d5, back in the initial room, to open. (However, if you went back to that room, you would notice no difference. That is because d5 is behind another secret door, d6, which shields its location.) In the upper area of the room, south from the location of switch s5, you will find a backpack and an ammo box.

The capriciously shaped room, which looks like a skull, located at the southwest corner of this structure, contains teleporter T1 between its eye-like pillars. Behind the teleporter, you will find a rocket launcher. The teleporter sends you to a satellite enclosure south of your location. This small enclosure houses switch s6. Activate this switch to open up secret door d6 way back in the initial entry room. Behind the double doors, you will find another bulk cell and a Soul Sphere.

The oddly shaped and very dark room at the northwest end of the installation houses a plasma rifle at its south end. On the north side along the east wall, you will run into switch s7, which simply opens the door and lets you inside a small room where there is a chainsaw and an energy cell.

The next switch, s8, is located straight south from the center of the installation. Activate this switch to lower the decoy computer console in the adjacent room. As the console descends, you will see the red card.

West of the red card's location is the room where the final exit is found. You'll note that although the exit is plain to see, a wide ooze pit prevents you from crossing. However, behind the red latch, you will find switch s9. This switch does two things. It opens secret door s9, west of the exit, unleashing a Cacodemon. But the switch also lowers to reveal a second switch, s10. This switch raises platform p10 from the ooze pit to let you reach the final exit.

TOWER OF BABEL

This is the ending level for The Shores of Hell episode, so you know you will be confronting the big Boss for this level, the demonic Cyberdemon. That in itself is the biggest challenge to this level. The simple and elegant structure of Tower of Babel poses no real threats or secrets, so we'll skip the regular list and general strategy discussion.

STEP BY STEP THROUGH THE TOWER OF BABEL

This level's layout looks like a shape you would see through a kaleidoscope, with each side being a mirror image of the opposite side.

Because this level is so drastically different from all others in this episode, a step-by-step discussion of your strategy is in order. Upon entering this level, you will find yourself in the small square room at the center of this structure. Notice the four-sided pillar in the middle and the four indentations on the walls, each gruesomely adorned with the limp and mangled body of a former Baron of Hell. Each of these indentations is in reality a secret door.

Each face of the central pillar has a switch. Each switch, in turn, causes stairs to rise in front of the secret door on the opposite side of the switch. Outside each of the four secret doors, there is a trigger that causes the door leading to that room to close. That is the essence of the layout.

But anyway you slice it, you will have to confront the Cyberdemon mano-a-mano. Fortunately for you, there are more than enough rocket cases in the adjoining rooms to let you have a fighting chance. There are

E2M8

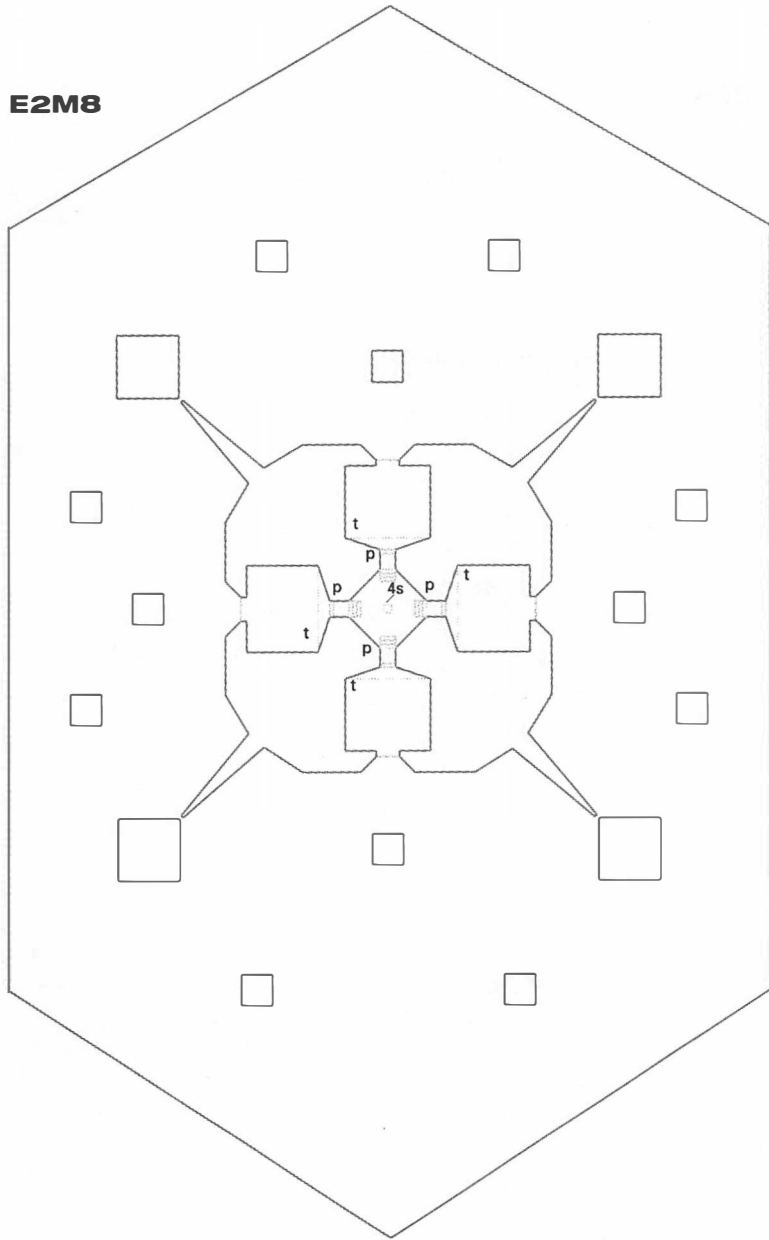

FIGURE 5.8A TOWER OF BABEL BLUEPRINTS. Triggers and switches.

E2M8

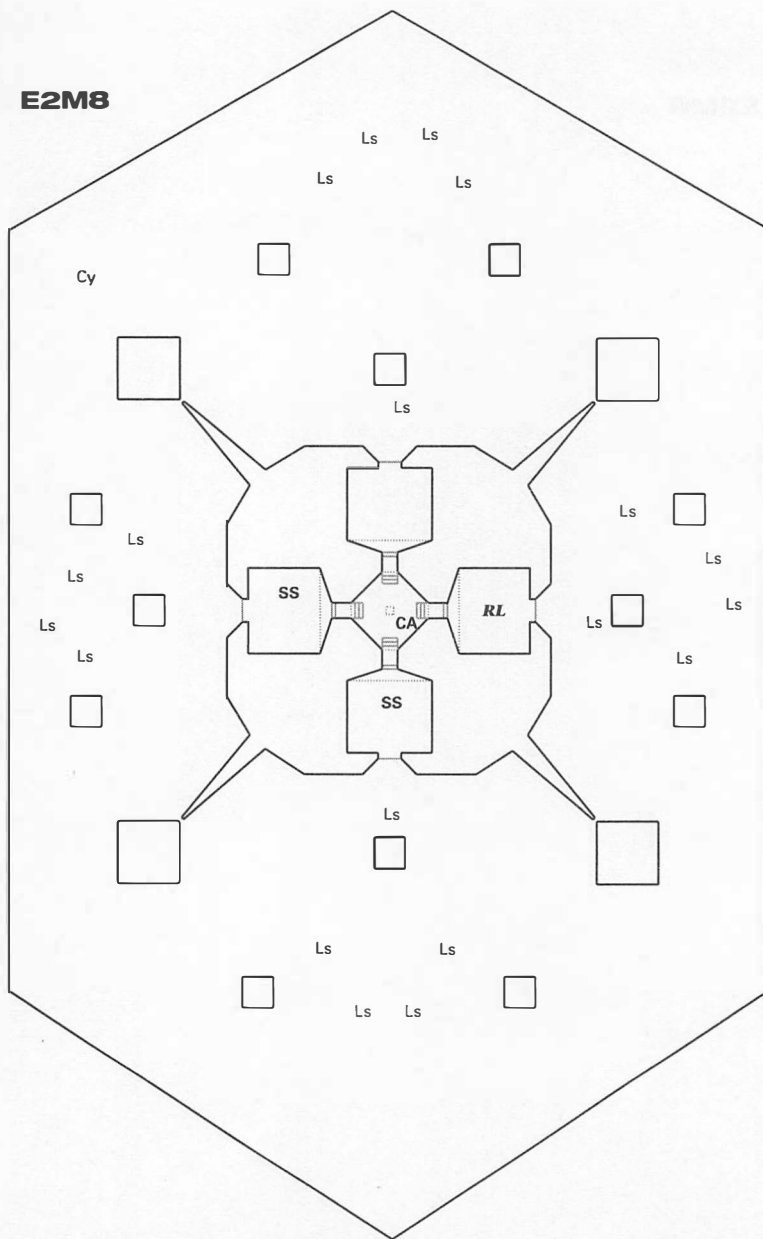
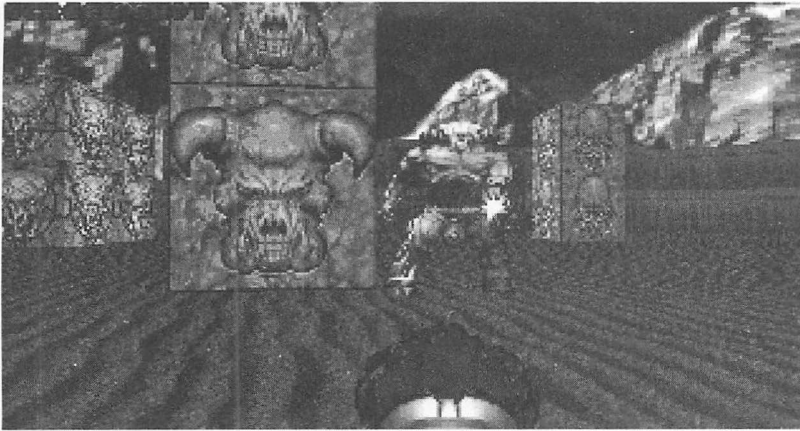

FIGURE 5.8B TOWER OF BABEL BLUEPRINTS. Monsters, weapons, and artifacts map.

also two Soul Spheres, one in the east room and one south. A single Combat Armor can also be had.

Your best strategy will be to open all secret doors in the central room. After raising the stairs for each door, each secret door will open when you approach it, as each has an activating trigger on its steps. When you venture



out into a room, you will not be able to return to the relative safety of the center unless you run around into the next room. Whenever you reach the center, you should, once again, open all doors. In this manner, you can take advantage of your speed over the Cyberdemon, although he is no slouch at all, and run for protection to the center whenever you

need to collect yourself and choose another path for unloading your rockets on the Cyberdemon.

If you have any cells from the previous level, you will also want to empty them on the Cyberdemon early on, and weaken him for the ensuing rocket shower.

The best way to confront the Cyberdemon is from a safe distance so you can dodge his heavy-duty rockets. Take shelter behind the many cubelike structures to avoid the rocket downpour. The Cyberdemon is easier to hit when he is standing. But if he stands, he does so to shoot. Notice that he always shoots three rocket in rapid succession. Try to time his attacks and retaliate when he has just fired the third rocket.

If you manage to hit the Baron early on with at least the contents of an entire bulk cell, you will have to feed him a steady diet of at least 30 rockets or more before he will succumb. The number will vary depending on the accuracy of your hits.

FORTRESS OF MYSTERY

The only way to reach this level is by uncovering the secret door in the Command Center. Like Tower of Babel, the Fortress of Mystery eschews complexity for a simple whimsical design. Because of its simple architecture, there is no need to describe or enumerate secret doors and triggers. However, there are a number of weapons and useful artifacts you may find in each structure, especially in the flower-like arena (refer to map). The trick is getting to the weapons before the Barons of Hell descend upon you. And you will be immediately surrounded by a brotherhood of Barons the second you arrive.

STEP BY STEP THROUGH THE FORTRESS OF MYSTERY

The first structure, where you materialize when entering this level, looks like a flower in full blossom. The adjoining structure to the east is in the shape of a simple cross. Radiating from the center of the cross are ooze canals.

You should avoid direct confrontations and attempt to retrieve every useful item from every room. Do not let yourself get cornered into battle.

When you are reasonably ready, your strategy should be to reach the entrance to the cross-shape installation and push open the door. When you do, a large contingent of swarming Cacodemons will be there to greet you. At this point, you don't have much of a chance to make it on your own. So entice the Barons to wage war against the Cacodemons. This can be done if you manage to make them enter a crossfire situation where you are in the middle.

As they begin fighting each other, try, from a safe distance, to help out the side that appears to be losing (usually the Cacodemons). After one side has won, pick off the survivors with cell blasts and a heavy rocket pounding.

After annihilating all the monsters, take a cursory tour of the cross room and pick up any other useful items. (There is a Soul Sphere at the intersection of the red ooze canals.) With all the useful items in your possession, head for the east wall. Push open the secret door. And enter a

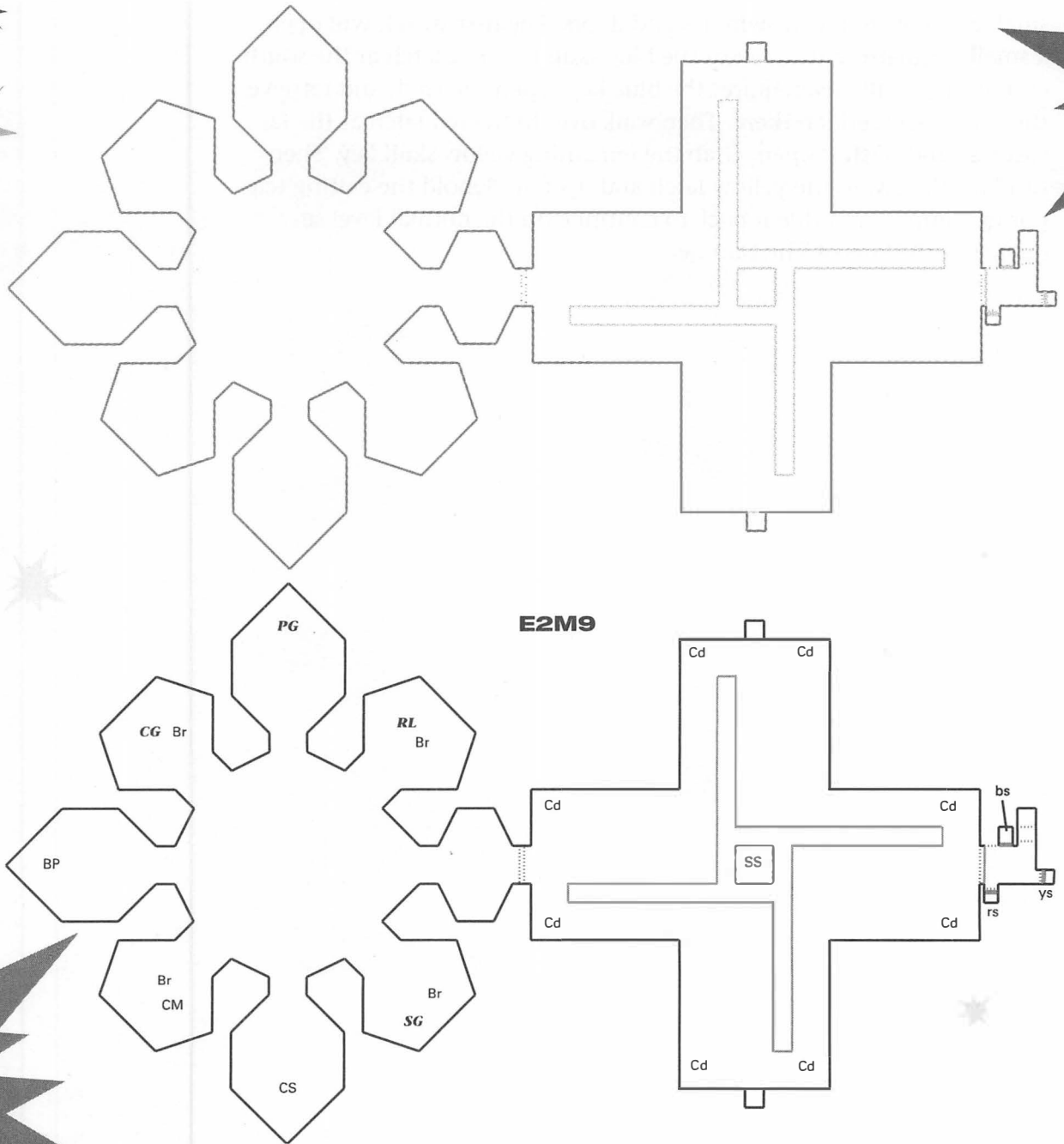

FIGURE 5.9 FORTRESS OF MYSTERY BLUEPRINTS. Top: Triggers and switches. Bottom: Monsters, weapons, and artifacts map.



small area covered with switches and doors. The first switch will open a small compartment to reveal the blue skull key. The latch at the south end of this small area requires the blue key. Open the latch and retrieve the yellow key hidden there. Then walk over to the red latch at the far east end and push it open. Grab the remaining yellow skull key. Then head north toward the yellow latch and open it. Behold the exiting teleporter. Jump in and ride it back to continue on the normal level sequence with Halls of The Damned.

INFERNO

S I X

Some might be relieved to know this is the third and last stop in the Doom trilogy. (For now.) Others of stronger visceral constitution might actually hunger for more. But regardless of your state of mind or your appetite, Inferno looms over your horizon. And it is not a pretty sight.

In this last Doom episode you will be fighting many more of the monsters you already know so well. But you won't forget you're in Hell for one minute. The gruesome installations and horrific landscapes are enough to disturb the sleep of the most just among us.

The boss in this episode is the terrible Spider Mastermind. You will get the dubious privilege of making its acquaintance if you have the strength of mind and spirit to endure the first seven hellish levels before you. Fortunately for you, in this episode you finally get to lay your hands on the gleaming BFG 9000. It could well be the answer to your prayers and your ticket out of Inferno.

The secret level in Inferno will make you think you're not quite well. You will keep asking yourself, "Haven't I been here before? Am I the butt of someone's cruel joke?" Getting to the secret level in this episode is a Herculean task. Only a handful out of hundreds of players can actually figure it out without help. There is only one way to reach the secret door. But rest assured that it can be done.

HELL KEEP

Resembling an artificial organ, Hell Keep will give your heart a nice jump start. The walls, the ground itself, and the surrounding scenery seem to writhe with life. After all, you are in Hell and anything is possible.

This installation is amazingly simple, and therein lies its beauty. You won't be besieged by perplexing puzzles and myriad switches and triggers. The challenge in this level comes mainly from its inhabitants.

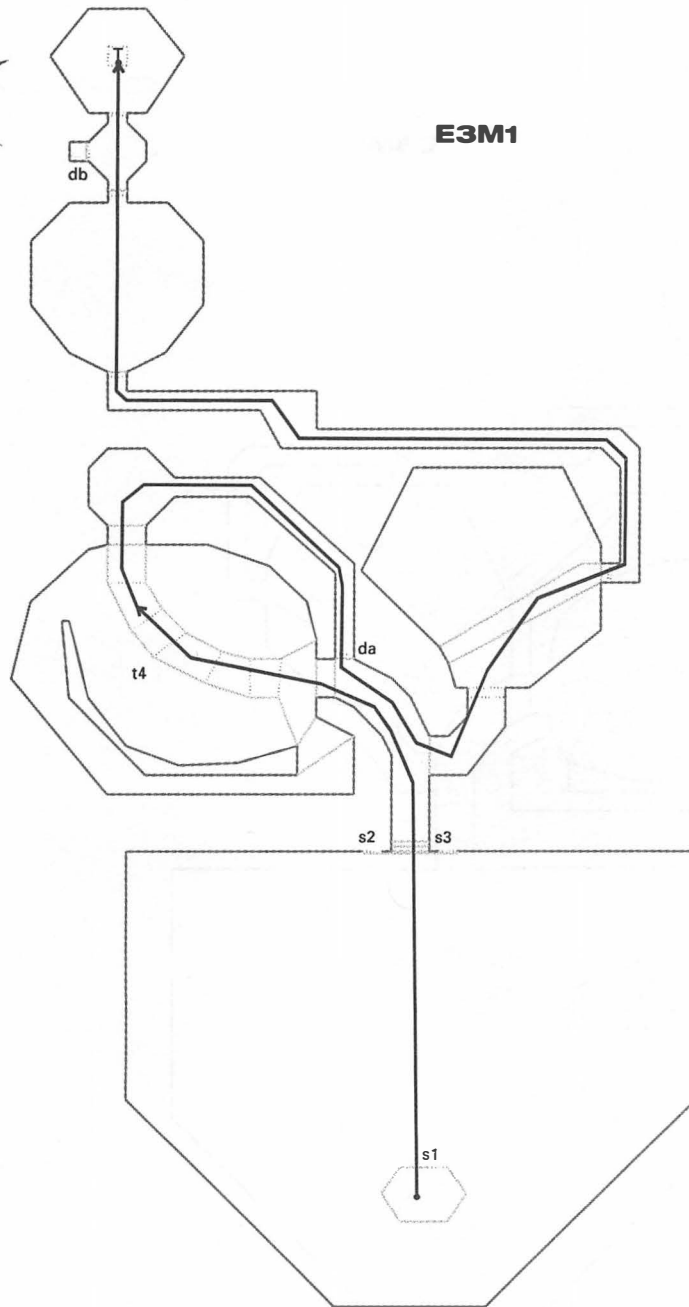

FIGURE 6.1A HELL KEEP BLUEPRINTS. Ideal route map, indicating triggers and switches.

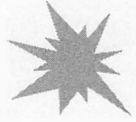
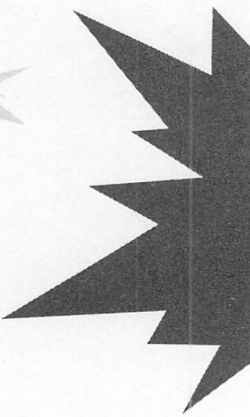
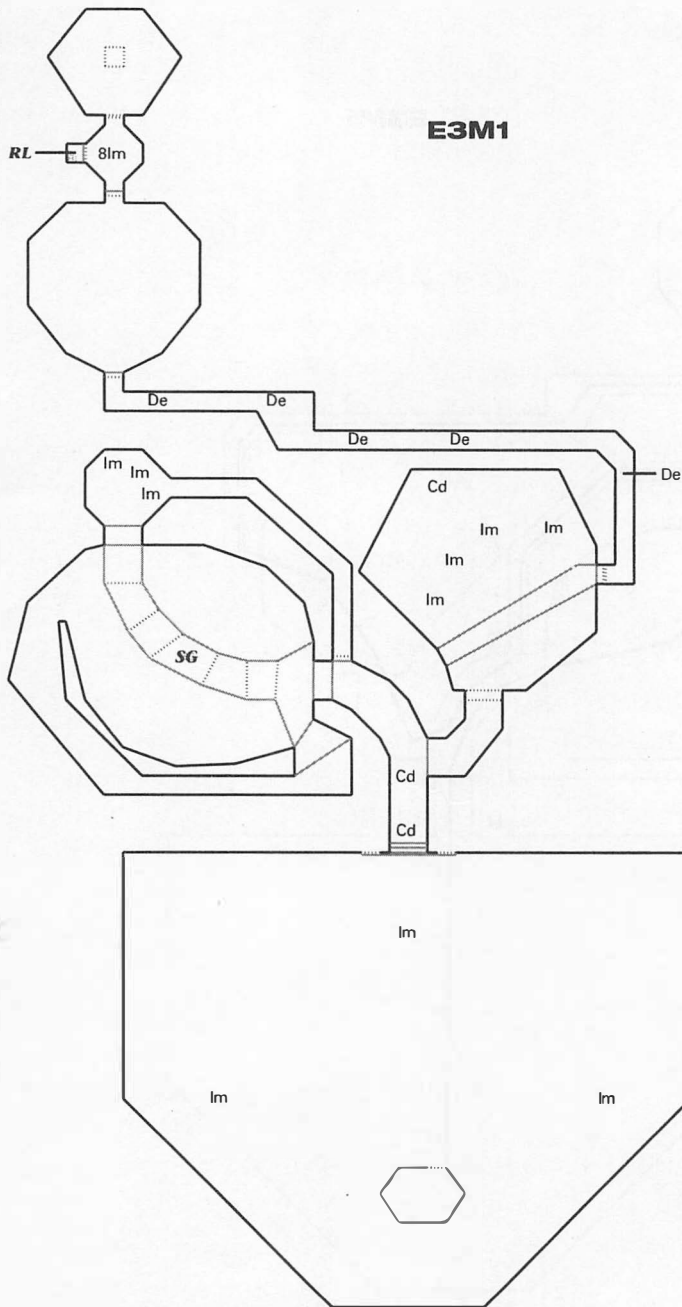
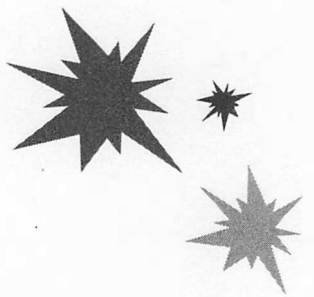
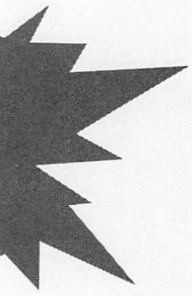

FIGURE 6.1B HELL KEEP BLUEPRINTS. Monsters, weapons, and artifacts map.



HELL KEEP: LIST

In this level there are only a handful of installation secrets: 3 switches, 4 sequential triggers, and 1 secret door. There are only 2 weapons to be had, the rocket launcher and the shotgun. Finally, as exit to Hell Keep, you will find a single teleporter.

GENERAL STRATEGY FOR HELL KEEP

Take advantage of your main strengths over the monsters: speed and intelligence. Use whatever open spaces you can find to put some safe distance between you and them. In the harder levels, you will have to tango with several Imps, a bunch of Demons in a confining corridor, and a few bloated Cacodemons. You don't have to kill every monster in sight to arrive at the exit. Know when to stand your ground and when to dash for it. Leave the heroics for those whose epitaphs will at least be read.

STEP BY STEP THROUGH HELL KEEP

Entering Hell Keep's gates: You start this level below the ground, cradled in a medium-size enclosure that seems to have been pieced together from human bone and tissue. Press the switch that looks like living flesh. A staring eye will appear in the center of the switch. Its purpose is open to interpretation. One can only surmise. Just the same, stay alert. As the platform of the enclosure rises to ground level, get your weapon ready. (A handgun is not the best weapon against the awaiting Imps, but it's all you have.)

You will emerge on a vast courtyard where the ground resembles the convoluted contortions of a human brain. Fire at the Imps who are eager to be your private guides in Hell. Politely decline their offer and, in way of a reply, bury as many lead slugs as you can into their bodies. Use the large open space and blaze trails as you avoid the fireballs. Get some good angles behind dead trees and fire at every opportunity.

To each side of the gate, at the north end of the courtyard, you will find a switch. The one on the left opens the gate; the other closes it. If you are playing at the harder difficulty levels, a Cacodemon or two may

be waiting just beyond the wooden door. You really don't have the firepower to deal with this situation. Confronting the Cacodemons with a single handgun is a losing proposition. There are two alternatives you might consider. Both rely on speed. The first technique, in addition, requires flawless coordination and execution. If you're not endowed with natural speed, opt for the second technique. It calls for the attainment of a shotgun before confronting the Cacodemons.

- 1** Draw the Cacodemons out and make them chase you into the courtyard. Lead them away from the gate. Then race back and activate the closing switch as you duck underneath and leave the Cacodemons locked out for good.
- 2** Just as in the previous option, draw the Cacodemons away from the gate. When you can, race back and enter the gate. Continue running to your left, in a northwesterly direction. You will see the shotgun waiting in the middle of the bridge. You will have to run the length of the bridge, for it collapses in stages as you advance, setting off a sequence of triggers under you. Grab the shotgun and don't stop running in spite of the wall at the end—it's merely illusory. You will go through the wall and find yourself in a small room with one or more malicious Imps. Use your shotgun and run into the corridor at the east side of the small room. You will eventually face a Demonic looking face on the wall panel at the end of the corridor. Push it. It is a secret door. Coming out, you will see that you've returned to your original location inside the gate. Now you can run out and face the Cacodemons on more even ground. Maintain a safe distance as you peg the Cacodemons and sidestep their ball lightning. Score six blasts per Cacodemon and then trample their deflated bodies.

UNCOVERING HELL KEEP'S SECRETS

Switch s1, looking disturbingly official, is located along the north wall of the flesh and bone enclosure you find yourself in at the start of the level. Skull switches s2 and s3, to the left and right of the gate, respectively, open and close it. Six sequential triggers make up the t4 system, which causes the bridge over the boiling pool of blood, northwest of the

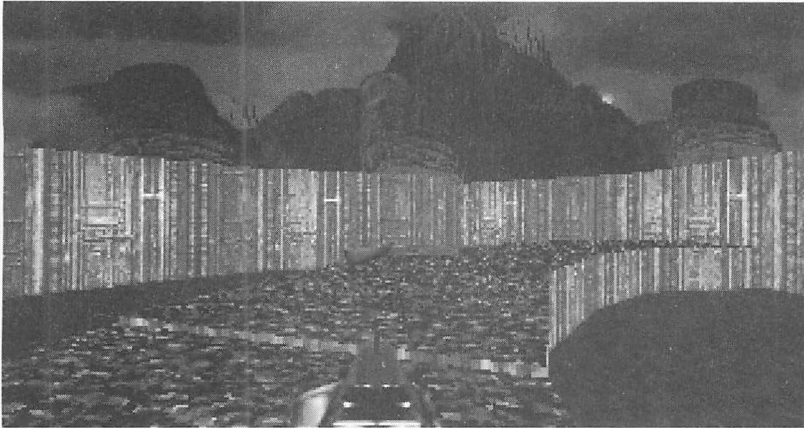

gate, to collapse. At the end of the collapsing bridge is an illusory wall. If you are fast enough crossing the bridge, you will run right through it.

Secret door da is found at the south end of the narrow corridor (east of the boiling blood). This door lets you out into the main hallway.

Secret door db is on the west side of the small enclosure between two larger rooms at the north end of Hell Keep. Behind this door, you will find a rocket launcher. North of this intermediate room, you will find the exiting teleporter in the middle of the northernmost hexagonal room.

SLOUGH OF DESPAIR

Even the most adept Doom player can sometimes use a hand. Slough of Despair's design offers an evil grip in its clutching design. But this is the hand destiny has dealt you. Could anyone but you play it through?

Slough of Despair gives you plenty of opportunities for exploring, but don't expect a pat on the back for your troubles. This level is characterized by an abundance of irregular rock formations and countless nooks and crannies. The disorienting effect of the irregular shapes is augmented by the wall's surfaces and textures, which resemble desert-type battle camouflage.

SLOUGH OF DESPAIR: LIST

The installation secrets include: 5 switches, 8 triggers, 4 secret doors, and 2 platforms. Among the useful items you will find 1 chaingun, 1 plasma rifle, 1 bulk cell, 2 rocket cases, 1 Security Armor, 1 Combat Armor, 2 cells, 1 rocket, 1 Soul Sphere, 1 Computer Level Map, and 1 blue skull key.

E3M2

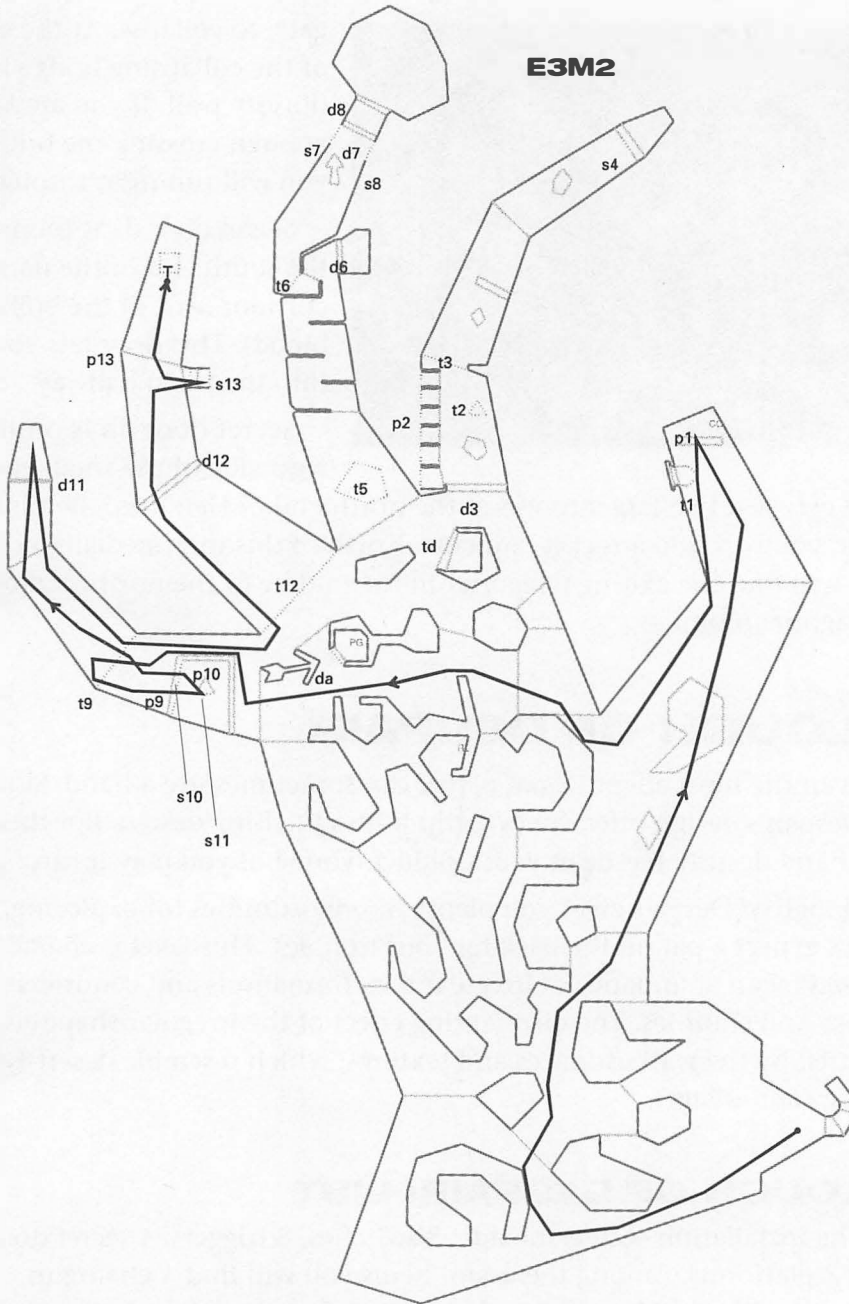

FIGURE 6.2A SLOUGH OF DESPAIR BLUEPRINTS. Ideal route map, indicating triggers and switches.

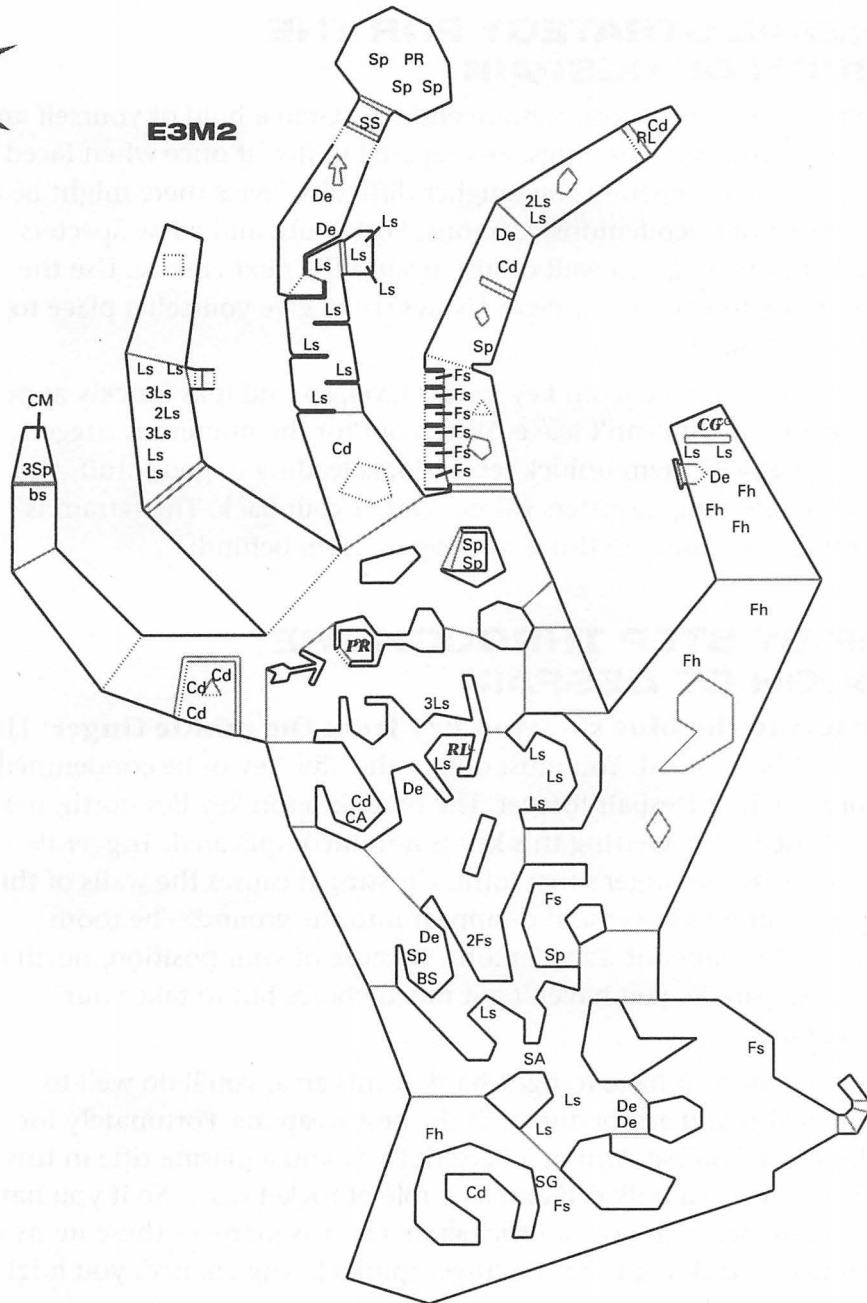

FIGURE 6.2B *SLOUGH OF DESPAIR BLUEPRINTS. Monsters, weapons, and artifacts map.*

GENERAL STRATEGY FOR THE SLOUGH OF DESPAIR

Don't let fear deplete your resourcefulness. Grab a hold of yourself and get a feel for your surroundings. Be prepared to flee at once when faced with a monster ambush. In the tougher difficulty levels there might be a good number of Cacodemons, Demons, Lost Souls, and a few Specters lurking behind any given wall or just around the next crevice. Use the various angles to your advantage. Always try to give yourself a place to back into in case of trouble.

There is only one skeleton key in this level, so find it as quickly as possible. Without it, you can't leave. Watch out for the numerous triggers. Although many of them unlock secret doors leading to good stuff, you will also be releasing monsters galore. Watch your back. The terrain is prime for anyone and anything to creep up from behind.

STEP BY STEP THROUGH THE SLOUGH OF DESPAIR

Retrieving the blue skeleton key from the pinkie finger: This task cannot be avoided. You must obtain the blue key or be condemned to roam Slough of Despair forever. The blue skeleton key lies north, near the tip of the finger. Getting this key is not uncomplicated. Trigger t9 stretches across the finger's first joint. Crossing it causes the walls of the big room behind to lower and disappear into the ground. The room holds a good number of Cacodemons. Because of your position, north of the monster parade, you haven't got much choice but to take your chances and fight.

Knowing you will have to fight hard in this area, you'll do well to build up health and armor and grab the best weapons. Fortunately for you, there is a Combat Armor, a Berserk Pack, and a plasma rifle in this level. There is also a bulk cell and a couple of rocket cases. So if you have a rocket launcher with you, all the better. Grab as many of these items as you can before tackling the little finger (pinkie). Any chances you might have will be greatly improved if you do.

Assuming you have the plasma gun or the rocket launcher and various rockets, proceed as follows. (If you wish to know how to get the bulk cell and the plasma rifle, read "Uncovering the Slough of Despair's Secrets.") Enter the narrow opening into the pinkie by the large walled area. Be sure you have the plasma rifle or rocket launcher at the ready. The walled area is the room where all the monsters anxiously await freedom.

Heading west, you will reach the first joint of the finger as the structure turns northwest. Run over the trigger going backwards. Start firing the second you see the walls descend. If you are firing the rocket launcher, watch your angle closely to avoid hitting a nearby wall. The quarters are tight; the action is fast and furious; but you must remain cool and collected. Back up toward the tip of the finger as much as you need to, but avoid being cornered. Good aim is at a premium. Show off your marksmanship.

If you've lived to tell about it, go back to where the room once was, stepping over alien corpses. As you cross into the room, another trigger causes a triangular pillar to rise. Activate the switch in the pillar and then go get your reward at the north end of the pinkie.

UNCOVERING THE SLOUGH OF DESPAIR'S SECRETS

The first Security Armor is near the south end, nestled between strange rock formations. Northeast of the Security Armor, a Berserk Pack sits cradled by a semicircular rock formation.

Trigger t1 is located in the thumb end of the installation. This trigger surrounds a small opening on the floor containing toxic goo. Cross over the trigger quickly to avoid any damage. The secret door, d1, north of the trigger, will lower, exposing a shiny chaingun.

The next set of secrets is found in the index finger. At the very tip, you will find a bulk cell and a rocket case, so this finger is worth exploring. As you enter the structure, you will notice a row of six Former Human Sergeants held in elevated cages on the west wall. Although they cannot presently jump down, the Sergeants are quite sentient and they will acknowledge your presence with their usual courtesy. Blast them as you

walk in. Hitting the impact wall behind them causes a triangular trigger, t2, to materialize in front of the cages. Walking over this trigger lowers the platforms so you can grab the Sergeants' shotguns. (The southernmost cage also holds a plasma cell.) Unfortunately, the trigger also lowers a secret door north of your location unleashing a vicious troop of alien thugs.

Proceeding north, you will cross trigger t3, which causes secret door d3, at the entrance of the finger, to rise and seal you in. Not to worry. Switch s5, found at the very tip of the index finger, causes the secret door to lower. The same switch also causes the wall in front of you to lower, revealing the bulk cell, the rocket case, and a superbad Cacodemon.

At the very tip of the middle finger, you will find another rocket case. Upon entering, crossing the pool at your feet sets off perimeter trigger t5. This in turn opens secret door d5. A charging Specter will come out charging. Behind d5, you will find a rocket, a Medikit, and a single cell.

Continuing north in the middle finger, you will reach the middle area where you must swing left and right to clear the metal walls. This area is home to many inhospitable Lost Souls who don't take kindly to any visitors.

Clearing the middle area, you will reach a small passage where you will trip trigger t6. Consequently, secret door d6 opens behind you and unloads a fresh batch of Lost Souls. Yet farther north in the middle finger, you will notice a glowing arrow pointing to switch s7. Activate this switch and the door in front opens, revealing a Soul Sphere. The switch on the right side, s8, causes a second door to open behind the Soul Sphere. Behind this door a few Cacodemons hover in anxious wait. The enclosure also holds a rocket case and a couple of Medikits.

The only secret door of this level, da, is found at the base of the ring finger. An arrow-like rock formation points directly to the secret door. Behind the door you will find the coveted plasma rifle and a Medikit.

The next set of secrets to discuss are in the pinkie. (The ring finger is the last structure to cover since it holds the exiting teleporter. In addition, the ring finger requires you to have the blue skull key to reveal the teleporter.) The entrance to the pinkie is made small by a large squarish room. The walls of this room are activated by t9 at the first joint of the

finger. Upon lowering, the squarish room releases a bevy of Cacodemons and Imps. Walking over the lowered walls sets off another trigger, t10, causing a triangular pillar to emerge from the ground. The south face of the pillar has a switch, s11. Activating the switch lowers secret door d11 at the north tip of the pinkie. The blue skull key sits in front of d11. Behind the door, you will find a computer map, a Medikit, an ammo box, and a shell case. There are also a few spooky Specters.

Upon stepping into the ring finger, you will set off trigger t12 and thus lower secret door d12, north of your location. A flaming wave of Lost Souls will surf in to drown you in fire. Along the east wall of the finger, you will see a door flanked by the symbol of the blue skull. You will need the blue key to open this door. Behind it, you will find switch s13. Push the switch and watch the northernmost wall drop revealing the exit teleporter.

PANDEMONIUM

This installation resembles, in look and feel, an elaborate torture contrivance from the Middle Ages. The central room, for instance, where switch s1 is found, looks much like a severed, upside-down head. The corridors and stairs connecting it to the rest of the installation seem to hold the head in a tight vise grip. Heavy and painful, Pandemonium is surprisingly economical in installation secrets. There are also a good many artifacts, including the coveted BFG 9000.

Complete with a fire lake, Pandemonium is dizzying and disturbing. Its heavy use of lifelike textures for many walls and installation structures will send your skin crawling under the bed.

PANDEMONIUM: LIST

There are only 5 switches, 3 triggers, 5 platforms, and 6 secret doors in Pandemonium. But the artifacts and weapons include: 1 Soul Sphere, 1 Security Armor, 1 Combat Armor, 1 computer map, 1 Invulnerability artifact, 1 Berserk Pack, 1 chaingun, 1 shotgun, 2 single cells, 1 backpack, 1 rocket launcher, 1 rocket, 1 bulk cell, 1 blue skull key, and finally, the BFG 9000.

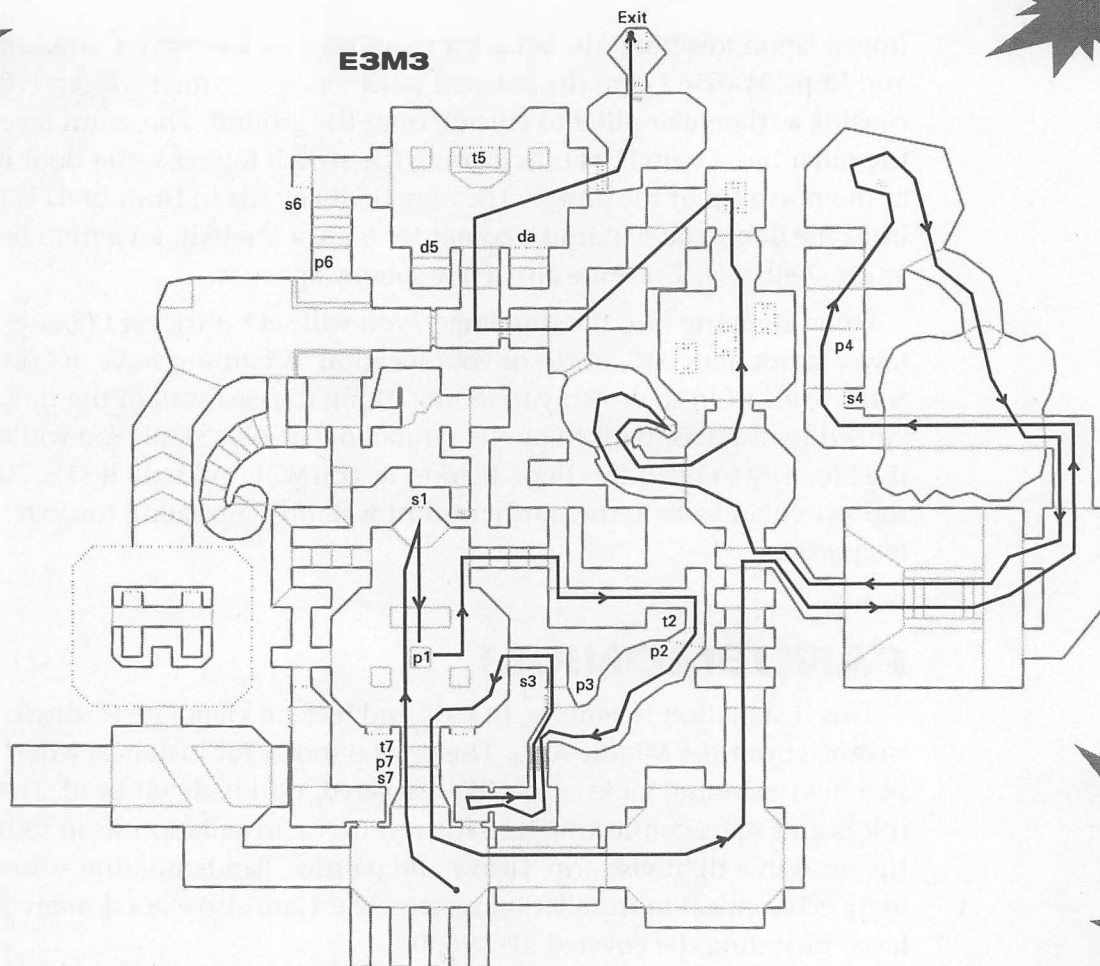

FIGURE 6.3A PANDEMONIUM BLUEPRINTS. *Ideal route map, indicating triggers and switches.*

GENERAL STRATEGY FOR PANDEMONIUM

Pandemonium is littered with just about every monster you can think of. In fact, even the feared Baron makes an appearance or two in this level, depending on how tough you play. No matter where you go, it seems like you are constantly surrounded by monsters in this level. This means that you must be able to change directions quickly and fire on the run. Use every wall and crevice to regroup and make every shot count.

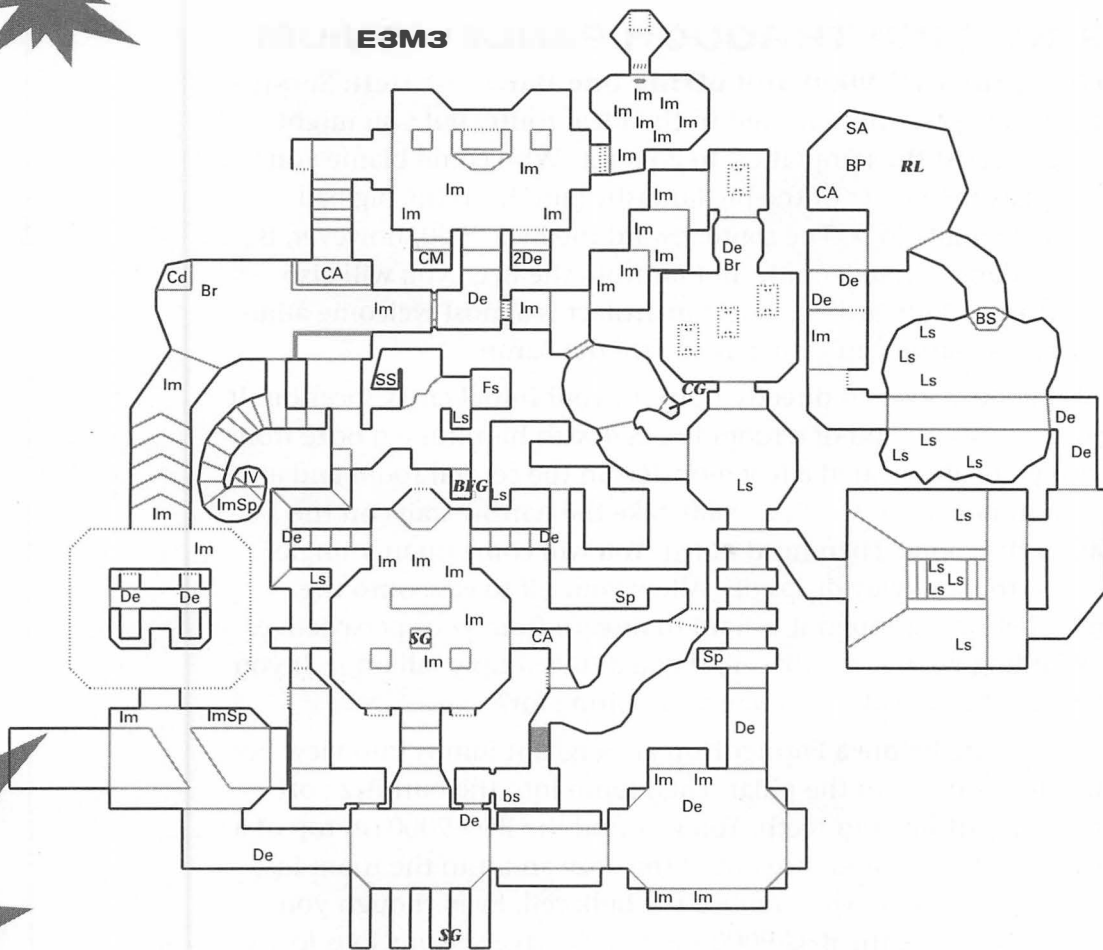

FIGURE 6.3B PANDEMONIUM BLUEPRINTS. Monsters, weapons, and artifacts map.

Any chance you might have against the Barons will be greatly improved if you can count on the destructive power of the BFG 9000, so you would do well to get it as soon as possible. To reach the exiting teleporter, you must go through a latch that requires the blue skull key. This item is of the utmost importance. You can't leave without it.

STEP BY STEP THROUGH PANDEMONIUM

Reaching the BFG 9000 and offing one Baron of Hell: Surprisingly, the BFG 9000 is not charted in the ideal route, but you might not be able to resist the temptation to go for it. Who could blame you? Nothing equals the power of the big fantastic gun. Even the big bad bosses are vulnerable to it. The route toward the BFG 9000, however, is fraught with danger. Incidentally, not far from the BFG, you will also find an Invulnerability artifact. Such an artifact is a most welcome addition to your arsenal as you get ready to face the Baron.

The BFG 9000 is located directly north of your initial entry location. It is lodged at the south end of a room flooded with harmful red ooze from Hell. Once you have cleared a few monsters in the central room and are ready to go in pursuit of the BFG 9000, take the narrow stairs on the west wall of the room. Then head north. You will come upon a single rocket. Then the walkway drops off. Allow yourself to ease onto the small pillar below. Although it is hard to discern from your perspective, you are standing next to a bulk cell, if you didn't simply fall on it. If you haven't grabbed it already, what are you waiting for?

It won't be long before a Former Human Sergeant jumps into view below you. Shoot him from the pillar. Then jump into the burning ooze and head east gritting your teeth. You will find the BFG 9000 on top of a small platform. Grab it and race out of the ooze and into the room just north of the pillar where you grabbed the bulk cell. Even though you will be tempted to use the BFG 9000 right away, save the precious loads for the Baron. Switch to your shotgun or chaingun and deal with any initial opposition in the small room.

Now that you have the big gun, your next move is to grab the Invulnerability artifact at the bottom of a semicircular staircase. Take the entrance at the southwest corner of the small square room. You will find yourself on green descending steps curving southward. Along the first step, you will see a small opening into a large room north of your position. That room is where the Baron awaits.

Blast the Imps on your way downstairs. At the very bottom you will also have to deal with a Specter. Then cross the small ooze pit and grab the turquoise-green Invulnerability artifact. Everything will look like a

photographic negative as you feel the surge of becoming suddenly invulnerable. Race back upstairs and enter the room where the Baron of Hell, a Cacodemon, and a few Imps stretch the welcome mat.

Blast the BFG 9000 as soon as you catch sight of the Baron. (The BFG

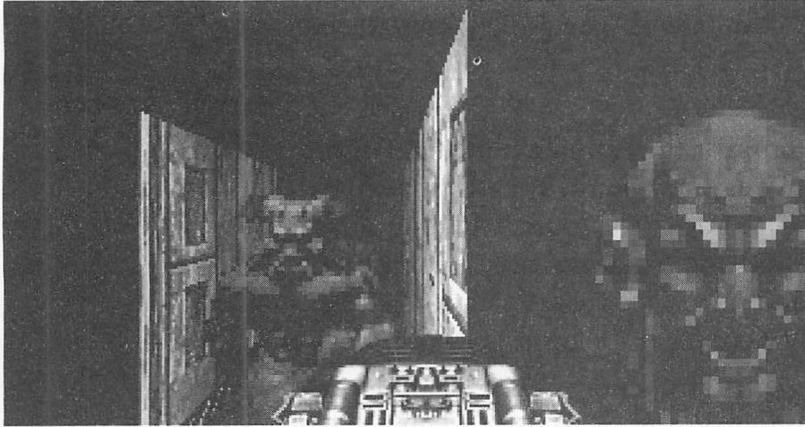

9000 is not a rapid-fire weapon. So you must fire each blast with a measure of anticipation.) Since you are momentarily invulnerable, you can maintain a relatively stationary position as you unload the contents of the BFG 9000 on your opponents. After exterminating every monster present in the room, you are now free to go in any direction.

UNCOVERING PANDEMONIUM'S SECRETS

Switch s1 is found on the north wall of the central room, up the stairs from your initial position. This switch lowers pillar p1 in the middle of the room. On the pillar is a shotgun.

Trigger t2 is located northeast of your initial position. It is available by taking the stairs on the east wall of the central room. This trigger will cause the small platform p2 to lower you into a curving alley-like enclosure. Following the alley southwest, you will reach a small downstairs room where you will find the blue skull key and a cell.

Switch s3, in the shape of something unmentionable (everybody's got one), is found at the west end of the alley enclosure. Activate this switch to raise the small platform on which you stand, p3, back upstairs. (This switch can only be activated one time.) Once upstairs you will find a Combat Armor and a Medikit. The floor radiates harmful radiation, so grab the stuff quickly and jump back down into the central room.

The next switch, s5, is found just east of the lake of fire in the eastern wing of Pandemonium. This switch causes platform p5 to rise just north of the switch. You need to raise this platform to reach the northeast end of the wing, but watch for a couple of Demons that emerge with the platform. At the northeast room, you will find a Security Armor, a backpack, a rocket launcher, and a few other useful items. The walkway southeast of this room takes you to a view of the lake of fire where you can grab a Berserk Pack.

The next installation trigger is found at the extreme north end of the installation, directly forward from your entry point. Trigger t5 is on the north side of the platform near the middle of the room. Crossing this trigger will cause secret door d5 to rise and make available a computer map. Also in this room, you will find secret door da, just east of the entrance to this room. There are only a couple of Demons behind that door.

Switch s6 is found along a wall recess at the northwest corner of the installation. Throw this switch to cause platform p6 to rise and give you access to a Combat Armor. The next trigger, t7, is located on the walkway upstairs and west from the central room. This trigger causes platform p7 to lower you into a rectangular room. Inside this room, another switch, s7, causes the same platform to rise.

HOUSE OF PAIN

Ouch! Exquisite pain. You've never felt it this intensely. You can almost taste it. This installation lives up to its name completely. In the harder difficulty levels, three Barons of Hell in key locations will make your life a living hell. House of Pain spreads its cruel tendrils like a cyber parasite over a large expanse of hellish real estate. Its long, wide corridors are balanced by an assortment of small, narrower hallways that end abruptly in small enclosures. If the road to hell is paved with good intentions, then House of Pain is a featured stop along the way. Fortunately for you, this structure houses a good number of weapons and heavy ammunition. There are enough bulk cells in this level to evaporate the formidable Barons. But finding what you need may cause you to cry tears of blood. The question remains: can you bear the House of Pain?

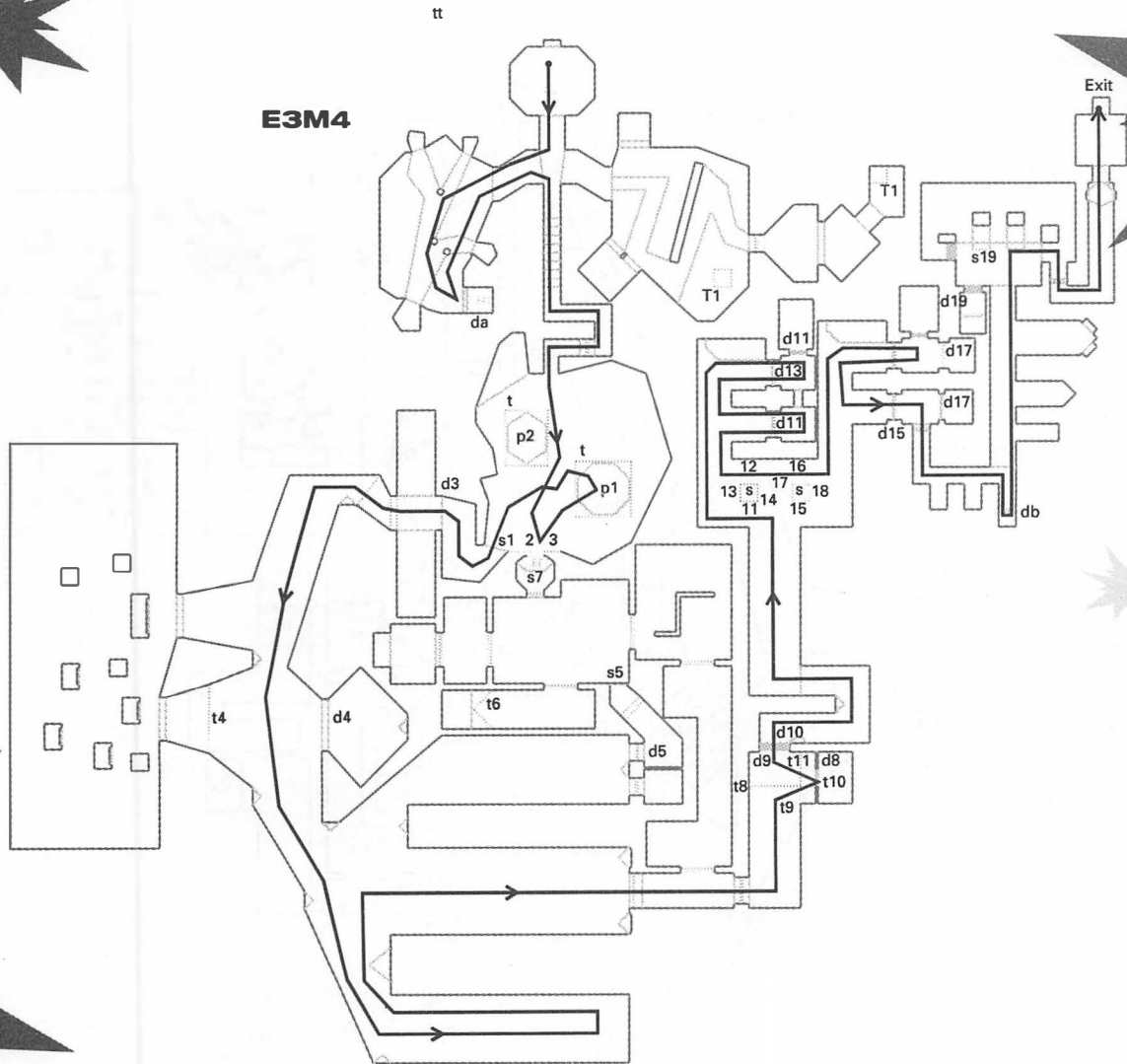

FIGURE 6.4A HOUSE OF PAIN BLUEPRINTS. *Ideal route map, indicating triggers and switches.*

HOUSE OF PAIN: LIST

There are a whopping 13 switches, 6 triggers, 14 secret doors, and 3 platforms in this installation. The weapons consist of 1 rocket launcher, 1 shotgun, 1 chaingun, and a BFG 9000. The ammunition

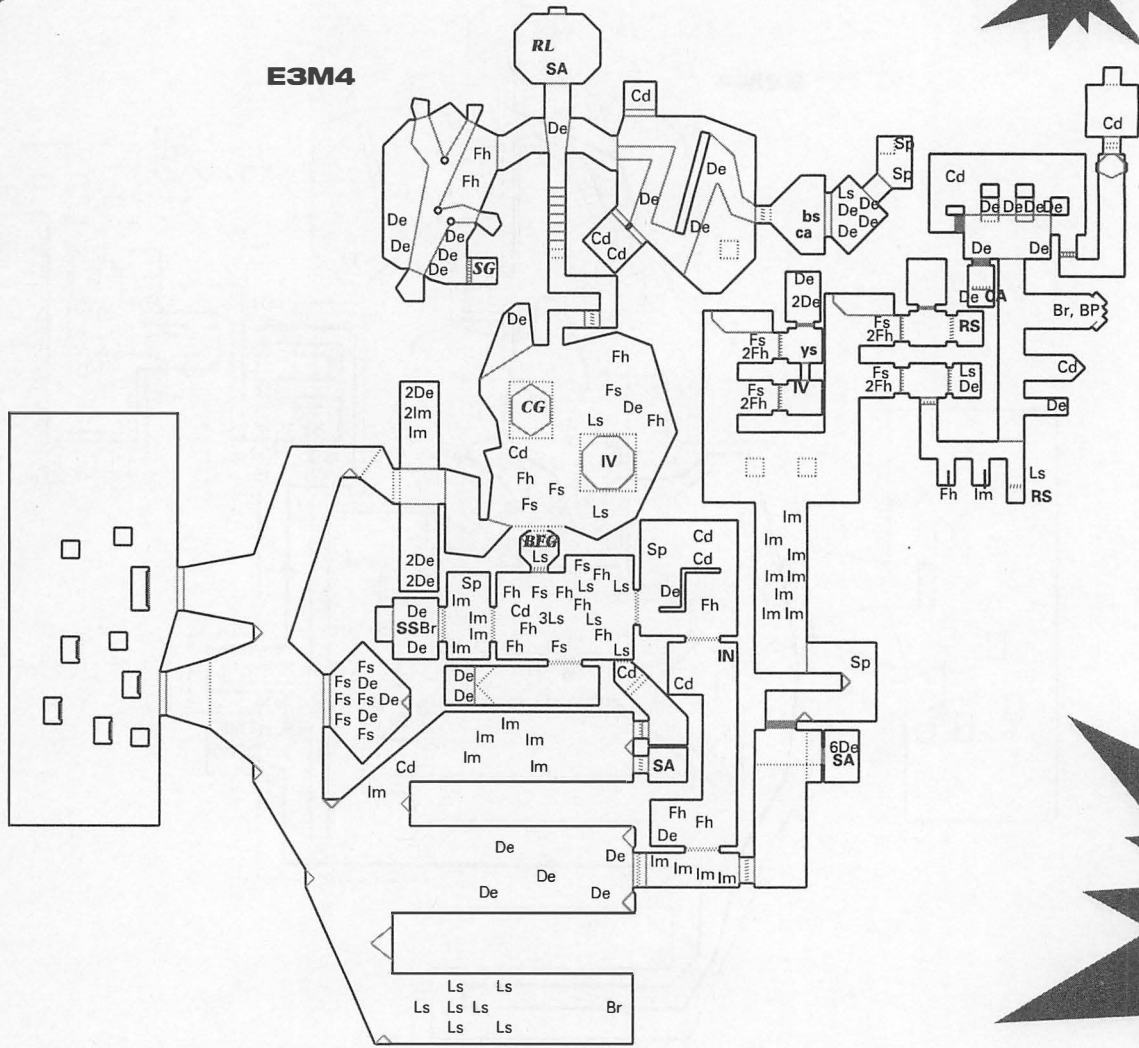

FIGURE 6.4B HOUSE OF PAIN BLUEPRINTS. Monsters, weapons, and artifacts map.

includes 4 single cells, 6 rocket boxes, 2 bulk cells, and 1 backpack. Among the artifacts, you will find 2 Combat Armors, 1 Security Armor, 1 Berserk Pack, 1 Invulnerability artifact, 1 Soul Sphere, and 1 radiation suit.

GENERAL STRATEGY FOR THE HOUSE OF PAIN

Hordes of Imps, Demons, Lost Souls, and Cacodemons guard the secrets of the House of Pain. Its top torturers, the Barons of Hell, don't know what mercy means. If you haven't got a rocket launcher and at least five rockets, you haven't got a prayer in this level. To succeed in Ultra Violence or Nightmare, you really need the BFG 9000, or, at the very least, the plasma rifle. Without either of these, you must rely on rockets. Luckily, there are more than plenty in this structure. The minimum recommended daily allowance for the House of Pain is fifteen.

The exit to this level is inaccessible unless you have all three skull keys with you. But having the keys by no means guarantees that you will make it to the exit. The most bruising moment in the House of Pain occurs in a room just yards away from the exit. This is where the plasma rifle or the BFG 9000 is absolutely essential.

The lay of the land in the House of Pain varies between large and small corridors. Work the space around you to your advantage. Getting cornered by a Baron of Hell is not conducive to good health. You also know the perils of using the rocket launcher in tight quarters. Save the plasma rifle or the BFG 9000 for those situations.

STEP BY STEP THROUGH THE HOUSE OF PAIN

Obtaining the BFG 9000: Your success in this level will depend largely on whether you can get the BFG 9000 and plenty of juice. The BFG 9000 lies hidden below ground level in a small enclosure near the center of the structure (just south of the central courtyard with the huge crushing pillars). Within close proximity of the BFG, there are three bulk cells and six cases full of rockets. If all this sounds too good to be true, that is because it is not as easy as it seems. To reach the BFG and the ammo, you must overcome some serious obstacles. To begin, you need the blue skull key. In the harder degrees of difficulty, a Baron looks over the key. Assuming you have secured the blue key, you must still clear two

rooms chock-full of Cacodemons and other unsavory monsters. Once you have the BFG 9000 in your hands, you might even feel powerful enough to fry the Baron of Hell who hangs out in the vicinity.

Using the blue skull key, open the latch at the east end of the center corridor. Be ready to pelt the Imps waiting just inside. The shotgun should suffice for you here. You will want to save the chaingun for the Cacodemons deeper inside. Open the next latch on the north wall and deal with the Former Humans and the Demon. Switch to the chaingun as you continue north, because you will run into a Cacodemon around the first bend.

Access the next room, still heading north. You will enter a square room with a partition in its center. Lurking behind the unseen side of the partition, two puffy Cacodemons await their prey. Besides the Cacodemons, you can also count on a Demon to complicate matters. If you have plenty of armor and top health, you can enter the room and spray the Cacodemons with bullets as you avoid the charging Demon. If health and armor are questionable, fire a few shots from the entrance of the room. Then retreat the way you came, with the Demon in pursuit. This technique isolates one enemy and you are then better able to dispose of him. Go back to the square room and overheat the muzzle of your chaingun.

The latch on the west wall of the square room opens into a large room buzzing with Lost Souls, Former Humans, Sergeants, and another floating killer tomato with one green eye—you know the one. As in the previous room, you might want to snipe the monsters from the entrance. However, given the wide arc of the room, and the fact that there is a good booty of rockets waiting inside, you can actually afford to spare a few rockets—if you have them.

The next stop in your tour of the middle area is the smaller rectangular room just south of your location. Reach this room via the latch at the south wall. There is a secret door at the west end of this rectangular room. Behind it are six rocket cases and two bulk cells. The door will open as you cross either of the triggers at each side of the door. But be prepared to back up and fire as two agitated Demons come bouncing your way.

Now you are ready to go back to the wide room and open the north latch leading to the BFG 9000. Don't be alarmed when you open the latch and do not see the much touted BFG—it is below ground level. To get it, run in quickly and head for the small hole in the center of the room. The floor here is incredibly painful, so be quick of foot. Falling into the small hole, you will land right on top of the BFG 9000. Notice the switch, s7, in front of you. Hit it to raise the platform up to the floor level. Then exit just as quickly as you entered.

Now that you have the BFG 9000, what are you going to do? If you exercise your new-found might, open two more sets of latches at the west end of the wide room. The first latch leads to a small area with a few Imps. Don't waste a BFG 9000 blast on them. Rather, choose the shotgun for simple efficiency. Behind the second latch is the heinous Baron. There is also a Soul Sphere to reward your efforts and restore you to good health.

Reach for the BFG 9000. Before opening the final latch, be sure the one behind you is open too. You will want to back up and give yourself some room to fire accurately. Remember that it takes the BFG 9000 what might seem like eternal instants to produce its blinding, evaporating discharge. Try not to jump when you hear the booming war cry of the hell-

ish Baron as you open the latch. You might want to press the BFG's trigger even before the latch opens completely. If you can do it, you might also want to begin backing up. It is unlikely that the Baron will survive the first point-blank blast. But if he does, avoid his energy projectile and deliver the *coup de grâce*.

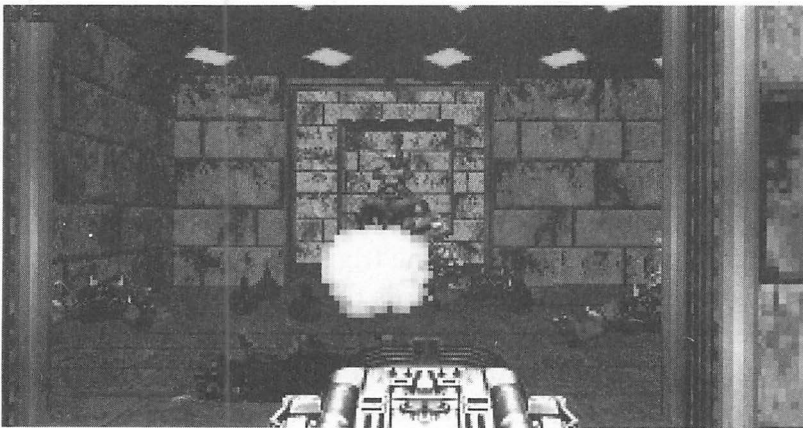

UNCOVERING THE HOUSE OF PAIN'S SECRETS

The first secret door, da, is directly southwest of your entry point, in an irregularly shaped room with a red canal running through its length. Shoot the ooze barrels in this room to wipe out the two Demons and Former Humans. Behind da you will find a shotgun, a cell, an ammo box, and a case of shells.

The east wing of the installation, near the entrance, takes you to a small area where you can find additional artifacts and ammunition. An angular bridge zigzags across the wide area leading to the room with the goods and keeps you from coming into contact with the pernicious red substance below. Near the entrance to the bridge, two cagelike rooms hold a Cacodemon each. You might want to off them before stepping in.

On the east side of the partition in this room, you will see a latch and teleporter T1. If you ride the teleporter, you will materialize behind the latch, at the far northeast end of this wing. You will be sealed inside a tiny room with a view of the adjoining room through a narrow opening in the thick wall. This is perfect for shooting the monsters on the other side, just like shooting ducks in a barrel. (You can teleport back to the outside once the deed is done.) Behind the latch you will find a Combat Armor, a Berserk Pack, and a single cell.

The next set of switches, s1, s2, and s3, are all found along the south wall of the central, roughly semicircular courtyard. Upon entering this large and open area, you will see two imposing pillars suspended over wide sunken areas on the ground. Each pit is really a platform—p1 and p2—that can be raised to ground level by throwing the appropriate switch. A perimeter trigger also surrounds each pit. Crossing the trigger will cause the huge pillar above to begin a pumping action. Cross the large open area avoiding the perimeter triggers. Then throw switches s1 and s2 and watch the platforms ascend. On top of platform p1 you will find an Invulnerability artifact while platform p2 offers a chaingun. Switch s3, adjacent to the other two, opens d3 on the east side of the circular room.

Halfway down the long arching corridor, heading southwest, crossing trigger t4 causes secret door d4 to raise. There is no booty to be had behind that door; just a bunch of menacing monsters.

The top hallway of the E-shaped structure leads to two latches. Behind the south latch you will find a Security Armor and a cell. The north latch is a one-way door that can only be opened from the outside. However, switch s5 located up the short corridor northwest, inside the little room, will open the latch again and let you out. But wouldn't you know, switch s5 is behind another latch. And to reach the switch you must first off the Cacodemon nestled in the tight space. Oh well. Say goodnight, Caco.

The blue skeleton key, guarded by the unbearable Baron, is found at the bottom rung of the E-shaped area.

Twin triggers t6, south of the central square room, cause d6 at the west end to raise. Behind this door are six rocket cases and two bulk cells. Switch s7 is inside the small circular enclosure where the BFG 9000 is found. You can only access this switch by pushing the latch open on the north wall of the central square room and jumping into the gaping hole inside the small enclosure. The switch will cause the sunken platform to rise to ground level. The room at the west end of the central area houses a Soul Sphere and a Baron of Hell.

The next set of installation secrets are located at the southeast corner of the House of Pain. Trigger t8, just in front of the harmful red floor, opens secret door d8 on the west side of the room, releasing a few Demons. Triggers t9 and t10 form the outside edges of the small blue puddle. Trigger t9 causes the latch at the north end of the room to open. Behind this latch is yet another latch. Crossing trigger t10 will raise the second latch. However, another trigger in close proximity, t11, will cause the second door to lower again. This will make it nearly impossible to exit the room from the right side. To keep the second door open, avoid crossing trigger t11. Instead, back up south of the health-draining red floor, and then run past the open latch.

At the far end of the hallway, past the set of double latches, you will run into two square pillars. There is a switch on every face of each pillar. The pillar on the left (west) side controls the action of the latches on the east side of the hall. Conversely, the pillar on the east side, controls the

latches of the rooms on the right side. All these switches work in pairs. Switch s11, for instance, opens two doors (pair d11): one at the far north room, the other in the middle short hallway. Switch s12, on the opposite side, causes these same doors to close. Switches s13 and s14 respectively open and close door d13. Behind this door you will find the yellow skull key.

In much the same fashion, switches s15 and s16, on the other pillar, open and close d15, respectively. Switches s17 and s18 open and close secret doors d17. Behind the north door d17, you will find the red skull key.

Secret door db is at the bottom end of the easternmost wing. Push this door open to uncover a radiation suit. Heading north along the red, glowing, and very harmful floor (which is incidentally lined with Medikits), you will find a backpack in the last walkway on the right side. But this is where you will also find an unsympathetic Baron of Hell. If you've got the plasma rifle or the BFG 9000, don't wait a second too long. Unload the cells and sizzle the Baron.

Once inside the north room at the end of the burning hallway, you will find switch s19 on the panel in front and to the left. This switch will open door d19, revealing a Combat Armor. To reach the final exit, you must jump down into the lower level of this room or take the stairs near switch s19. Don't put down your plasma rifle or BFG 9000 yet. A Cacodemon and some Demons won't make things easy in the very confining space.

Circle your way to the southeast hallway and follow the path until you enter the peaceful blue room. Head straight for the exiting switch. You've made it!

UNHOLY CATHEDRAL

Majestic in stature, this structure will dwarf you under its high and massive walls. Borrowing from Renaissance architectural styles, the Unholy Cathedral is the St. Peter's of Inferno. There is vastness of space in the central area and a network of smaller "chapels" in the periphery.

Each chapel is unique and offers some rewards and various challenges. Of these, the most dangerous is located at the far east, where the exit is found. A dimensional rift in its center allows creatures to materialize

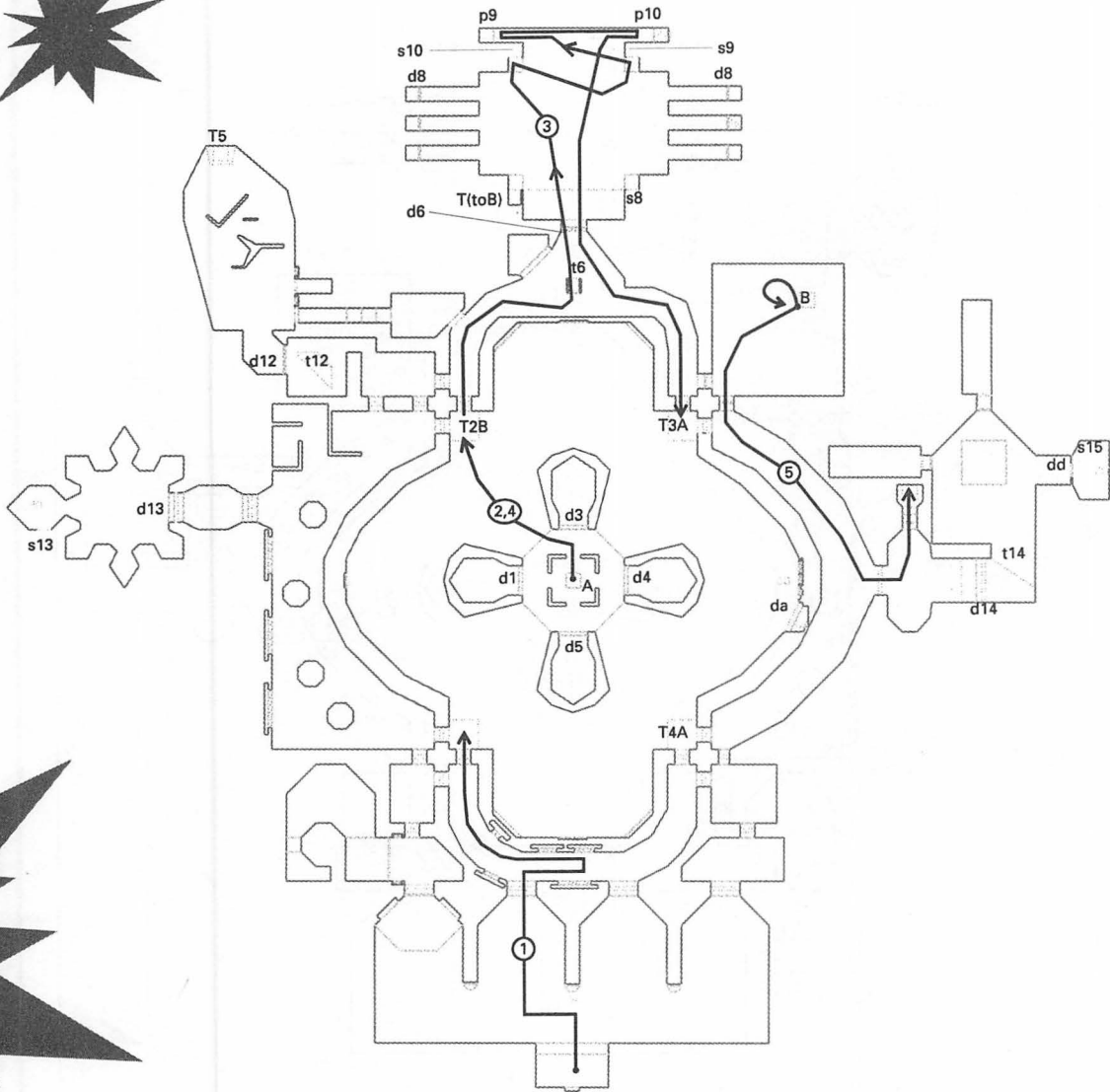

FIGURE 6.5A UNHOLY CATHEDRAL BLUEPRINTS. Ideal route map, indicating triggers and switches.

from beyond the Anomaly. One such creature is the Baron of Hell. The most daring players might feel obliged to enter the room in spite of the Baron and the rift and retrieve the BFG 9000 lodged behind a secret door.

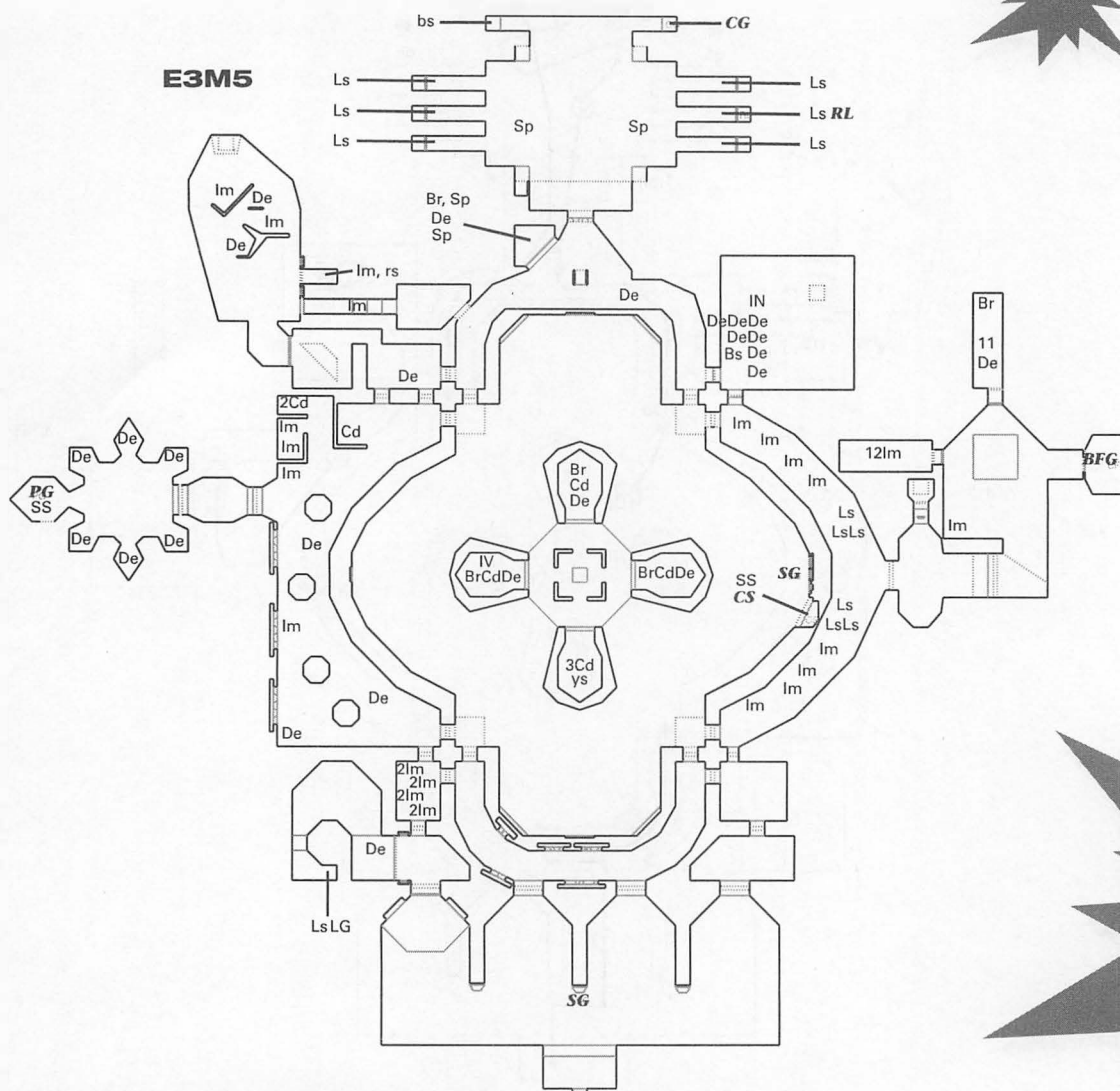

FIGURE 6.5B *UNHOLY CATHEDRAL BLUEPRINTS. Monsters, weapons, and artifacts map.*

Adding a supernatural touch to this level, teleporters make a big comeback—with a peculiar twist in their operation. In all, the Unholy Cathedral is awe-inspiring; even non-believers might drop to their knees, humbled.

But in the Unholy Cathedral no act of contrition can absolve you from eternal damnation. The price of redemption may well cost you your soul.

UNHOLY CATHEDRAL: LIST

On paper, the Unholy Cathedral may look deceptively simple. In reality, there are a large number of installation secrets. There are 8 teleporters. (Of these, teleporter A works as a one-way teleporter. You can materialize in it but not from it.) There are also 5 switches, 14 secret doors, 4 triggers, and 2 platforms.

The weapons and artifacts consist of: 1 rocket launcher, 1 chaingun, 1 chainsaw, 1 plasma rifle, 1 BFG 9000, 1 Invulnerability artifact, 1 Berserk Pack, 1 Invisibility Blur, 1 radiation suit, 1 Soul Sphere, and 1 pair of light amplification goggles. The ammo includes 2 bulk cells, 1 rocket case, and various single rockets. Finally, there are a yellow and a blue skull key in this level.

GENERAL STRATEGY FOR THE UNHOLY CATHEDRAL

The key to solving the Cathedral's architectural riddle is within reach once you understand how the teleporters work in this level. Also, even though there are two skull keys, you only need the blue one to make it to the exit. If you are playing at the harder difficulty levels, you may be squaring off with as many as six Barons if you decide to uncover every secret of this unholy installation.

Having said this, here is what you need to know about the teleporters. Notice the peripheral corridor surrounding the entire area of the central room. This corridor lets you access each teleporter from outside the central room. Of course, you can also reach the teleporters from within the large central area.

When boarded from either side, three of the teleporters (T1A, T3A, and T4A) send you to the center of the structure, the one-way teleporter denoted simply as "A" in the blueprint map. The teleporter at the northwest corner of the central area, T2B, sends you to the teleporter designated "B" in the map, found in the northeast square room.

The difference is that teleporters T1A, T3A, and T4A, if accessed from the periphery, not only send you to the central one-way teleporter, they also cause a secret door to open around the one-way teleporter at the center. There are a total of four secret doors flanking the central one-way teleporter, much like the petals of a flower around its center.

Your past experience with secret doors can attest to the fact that you will be unleashing monsters and uncovering weapons and artifacts. So be ready whenever you teleport from the periphery.

STEP BY STEP THROUGH THE UNHOLY CATHEDRAL

Wrestling the BFG 9000 from the creatures in the dimensional rift chapel: If you have made it to the blue door at the east end of the Unholy Cathedral, you can simply march in and go for the exit. But if you don't want to pass up a BFG 9000 behind the large door at the east side of the room, you are in for a tough struggle.

Within seconds of entering the room east of the exit, the large square shallow pit in the center of the room, which serves as a spawning medium for creatures from beyond, may start spewing forth a good quantity of monsters, including a bullish Baron of Hell. And to complicate matters, trigger t14, located diagonally a few feet in front of the latch, causes door d14 to close and seal you in this room. The BFG 9000 is found behind door dd along the east side of the room.

If you have the plasma rifle when you reach this point, you can probably stand to stay in and go charging for the BFG 9000. This is definitely a daring move and one that will make your adrenaline soar. However, if you only have a few rockets left or are limited to the chaingun or the shotgun, you are best advised to draw the monsters out and deal with them on your own terms.

Let us discuss that first, daring technique. Push open the door and, with plasma rifle at the ready, run forward and head for door dd. If you can, keep your eye on the dimensional rift in the center of the room. You might have to blast the first barrage of monsters before you have a chance to push open door dd. Once inside, grab the cells but not the BFG 9000. (You will want to save that for the Baron. When things quiet

down the tiniest bit, grab the BFG 9000.) From the relative safety of the small room, continue blasting plasma charges at the emerging monsters. Then watch the Baron emerge and rush forward as you unload a pulverizing BFG 9000 blast. You might have to use two full discharges to clear out the room completely. Then press switch s15 and exit the room.

For the “safer” technique, where you draw the monsters out, consider this advice. Push open the door, fire a few shots inside, but avoid crossing trigger t14. You want to avoid getting locked in. Back out into the

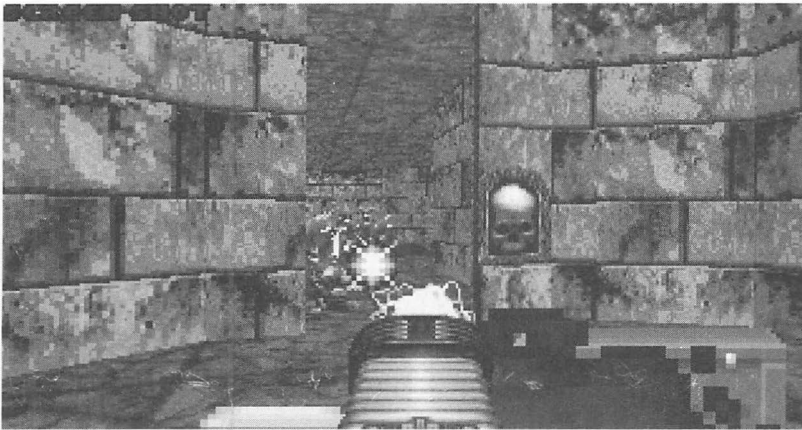

hallway, even outside the blue door if you like. As the monsters begin emerging to the outside, pick them off one at a time. When the latch closes after a few seconds, go back and push it open again. Then retreat and start picking off monsters again. This technique exposes you the least and gives you the upper hand as you snipe monsters before they have a chance to react.

After a few seconds the Baron will emerge too. If you have five rockets, make him come after you. Then administer the rockets in rapid succession. If not, rush past him inside the room and head for the BFG 9000. Open door dd and grab the BFG, the cells, and rocket case. Turn around, find the Baron, and unload the BFG.

UNCOVERING THE UNHOLY CATHEDRAL'S SECRETS

Teleporting into the one-way teleporter, A, from the peripheral corridor at teleporters T1A, T3A, or T4A, will cause the respective secret door (d1, d3, or d4) to open and unearth some monsters, and some beneficial artifacts as well.

Secret door d1 unleashes a Baron of Hell. There is also an Invulnerability artifact behind that door. Door d3 unleashes another Baron and

makes available an ammo box and two Medikits. Door d4 also releases a Baron and gives you a chance to grab a bunch of health potions and an ammo box. Finally, d5, which opens only after reaching teleporter T5 at the northwest room, releases as many as three Cacodemons. The yellow skull key is also found behind d5.

Teleporter T2B, at the northwest corner of the central area, takes you to teleporter TB, located at the northeast square room outside the central area. In this room you will find a few Demons, a Blur artifact, a Berserk Pack, and various Medikits.

Once you have the yellow skull key, you can push open secret door da, which is found just south of the strange red inscription at the east end of the open central area. Behind it you will find the chainsaw and a Soul Sphere.

Secret door db is found just northwest of the central area. Behind this door you will climb a few stairs and reach a single rocket. In this same general area, you will find perimeter trigger t12, which surrounds a toxic puddle. Walking over this trigger will raise secret door d12, giving you access to a room with an incandescent and hurtful floor. Along the east wall of this room, between two symbols on the wall, you will find secret door dc. Push it and grab the radiation suit. (You will have to kill the Imp standing guard.) At the north end of this room, you will find teleporter T5A and a bulk cell to its side. Teleporter T5A puts you back in the one-way teleporter A in the central area. It also opens secret door d5, behind which is the yellow skull key.

At the left wing of the Cathedral is a curious star-shaped room where another bulk cell and a plasma rifle can be found. After entering this room, the door will close behind you. You should rush straight ahead and grab the weapon and the bulk cell. Switch s13 is in the small room at the very west end. Push it to open the door to this exterior chapel so you can exit.

Secret door dd is found at the southwest end of the installation. Push this door open to access various health potions and, following the curving path into a small recess, the light amplification goggles.

Behind the blue door, at the east wing of the Cathedral, you will find the exit to this level. Also, behind the large, skull-covered latch, you will enter a dimensional rift area where a large sunken pit serves as a sort of interdimensional conduit, allowing monsters from beyond to materialize in front of your disbelieving eyes. In the harder levels, among these monsters is the feared Baron of Hell.

MOUNT EREBUS

In Greek mythology, Erebus is the mysterious darkness through which the souls of the dead pass on their way to Hades. Personified, Erebus was the son of Chaos and the brother of Night (Nyx). Mount Erebus is also the name of a volcano. And, of course, Mount Erebus is the installation you are about to experience during your infernal scenic tour of Doom.

For all its imminent fatality, Mount Erebus's design is whimsical and playful. Roughly resembling a faceted jewel, Mount Erebus almost seems to glitter with irregular prisms of bouncing light.

Much of the punishment administered in this level is dispensed by tightly packed hordes of Imps, Demons, Lost Souls, and bouncing Cacodemons. These beasts seem to spring from every secret door. And there seems to be one at the turn of every corner. And in Ultra Violence, there's also a Baron of Hell.

Adding an element of ever-pressing danger, the entire structure floats on a veritable lake of pernicious red ooze. Mount Erebus is also the connection to Doom's third and final secret level, the very bizarre Warrens. But even if you know where the secret exit is, getting there may elude all but the most observant players.

MOUNT EREBUS: LIST

Mount Erebus has 3 switches, 6 teleporters, 6 triggers, and 10 secret doors. This level is surprisingly thin, weapons-wise. There are 3 shotguns, one plasma rifle, and 1 chainsaw. The useful items include 2 Invulnerability artifacts, 4 radiation suits, 3 Security Armors, 1 Combat Armor, 1 Soul

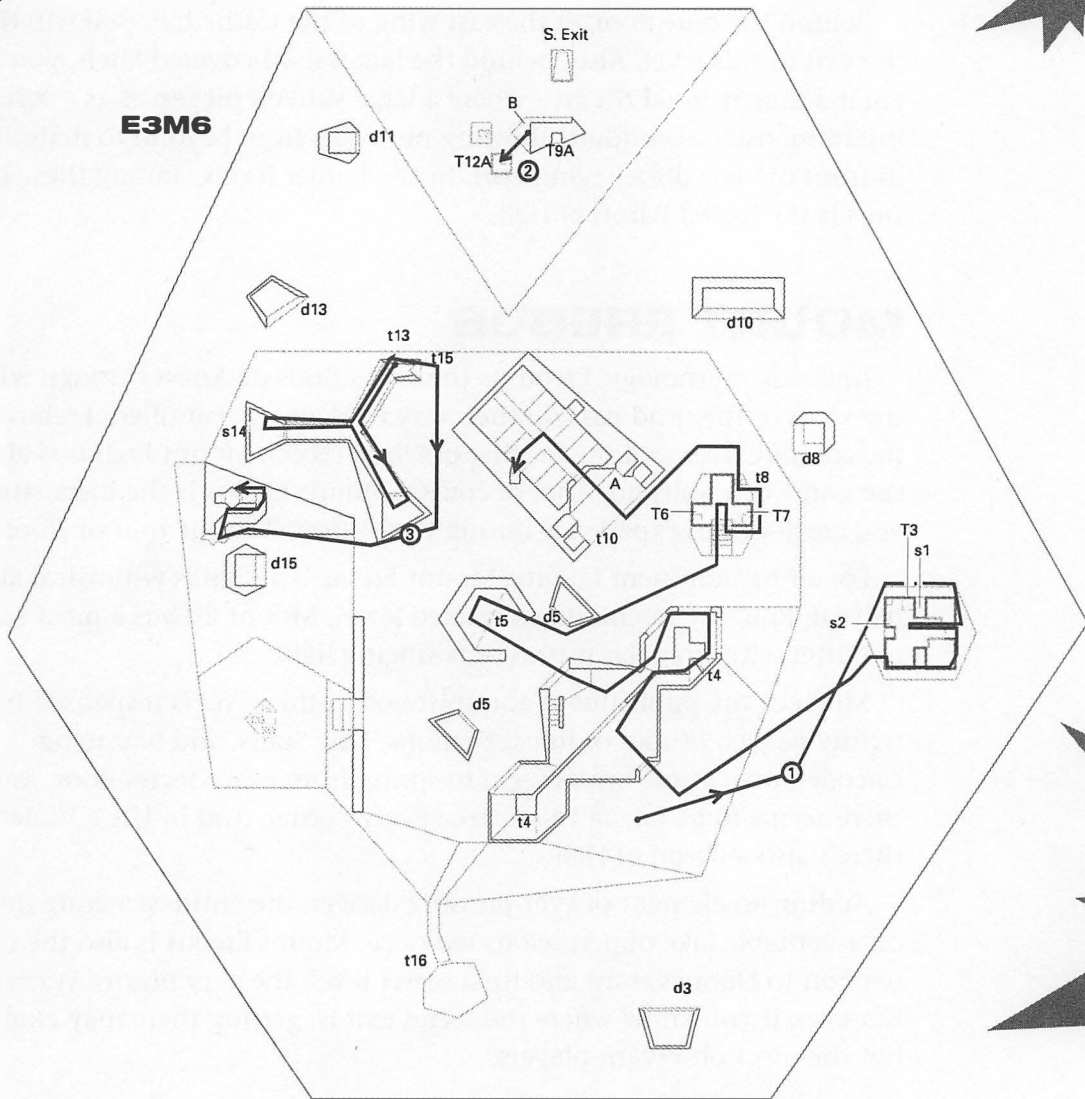

FIGURE 6.6A MOUNT EREBUS BLUEPRINTS. Ideal route map, indicating triggers and switches.

Sphere, 1 computer map, 1 pair of amplification goggles, and 1 Berserk Pack. The ammo includes a backpack, 4 single rockets, 2 rocket cases, and 2 bulk cells. The only key in Mount Erebus is the blue skull key.



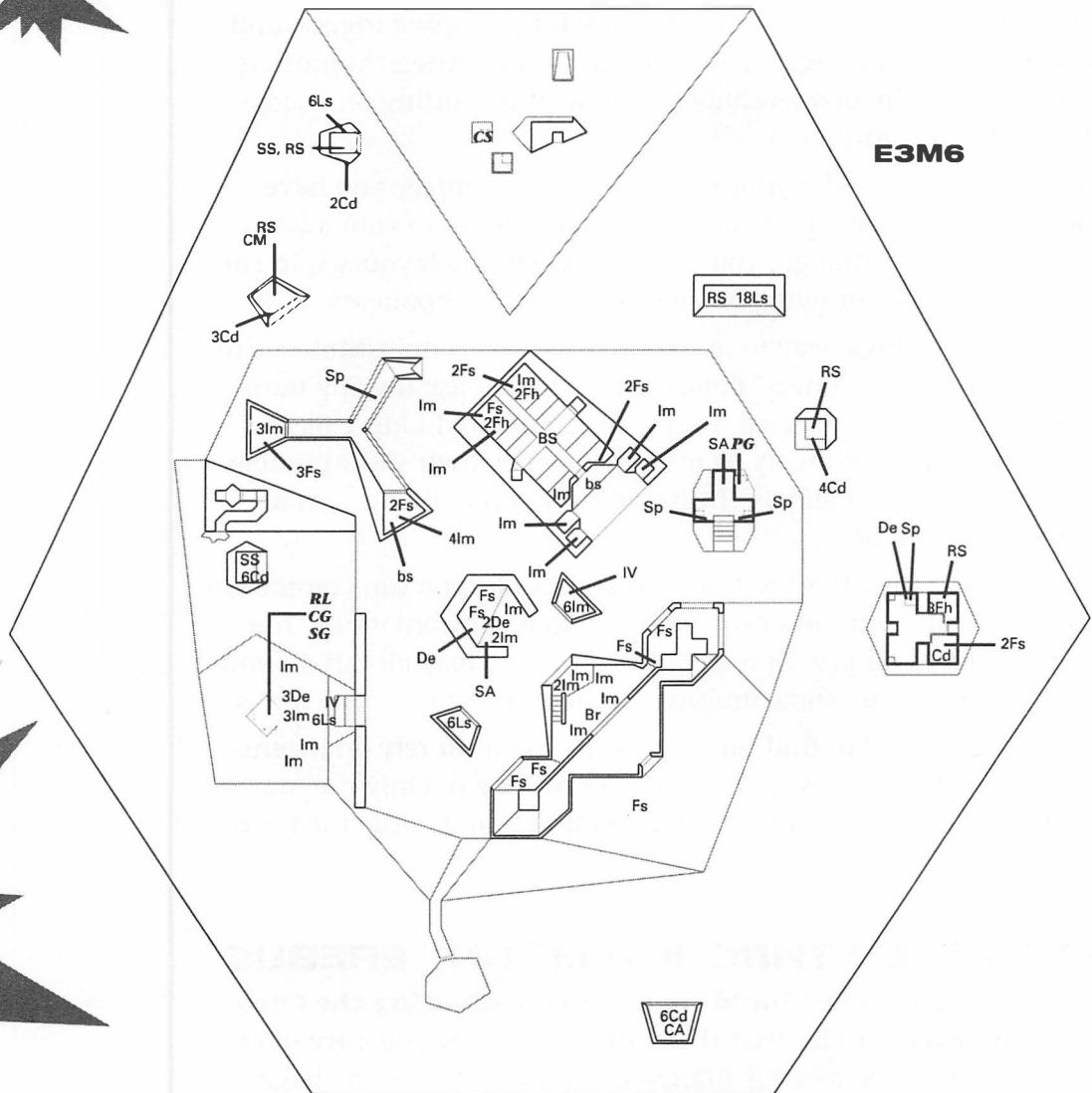

FIGURE 6.6B MOUNT EREBUS BLUEPRINTS. Monsters, weapons, and artifacts map.

GENERAL STRATEGY FOR MOUNT EREBUS

Fight hard, but most of all, fight smart. Mount Erebus is basically one huge battle with a few interspersed moments of heavy panting. As you

move through this installation, you are constantly tripping triggers and turning loose what might seem like tidal waves of monsters. Mount Erebus consists essentially of a few building installations sitting on a large expanse of open territory.

As you well know, besides your wits, the main advantage you have over the monsters is your speed. So use the open spaces to your advantage. When necessary, though, you will want to entrench yourself in confined quarters so you can swing out and punish your opponents.

Perhaps the best single way to make it in this level is to institute a variation of the "take no prisoners" policy. That is, avoid leaving any monsters loose once they are released from their temporary holding places. Otherwise you could eventually be overwhelmed by their sheer number. You will need to pull out all your heavy artillery and build up your armor as much as possible.

If you intend to clear this level as soon as possible, you can completely bypass some installations and avoid many serious confrontations. You just need the blue skull key. However, if you want to reap all installation secrets, you must endure some bruising moments courtesy of the locals.

Finally, if you intend to find the secret exit, you must rely on ingenuity to get you there. There is only one way of making it. Only the most cunning find it. Only the daring even attempt to find it. Only the fortunate survive.

STEP BY STEP THROUGH MOUNT EREBUS

Securing the southeast building and exterminating the Cacodemons southeast of the installation: Any chance you have of exploring this level can be severely limited if you fail to secure the large diagonal building near the southeast corner of the paved area. This building has an elevated floor from which it is possible to scope out the rest of the installation. Unless you kill the various Imps and Former Human Sergeants nestled there, you will be under constant fire almost no matter where you go.

The key location of this building makes it imperative to take it as quickly as possible. However, in doing so, you will inevitably set off one or two triggers and release an infernal family of Cacodemons from a

small enclosure south of the building. These Cacodemons must be exterminated. Otherwise, they will add their might to the adversaries you will face off before too long.

As you attempt to enter the diagonal, three-chamber building, you are greeted by a shower of fireballs. Various Imps, moving to and fro along an elevated platform, will do their best to fry you where you stand. You are essentially protected by the door. Practice your sniping techniques, opening the door to fire and then moving rapidly away to either side. If your shooting ability is good, you can try standing on the threshold to keep the door from closing. You can then pick off the Imps as though you were shooting moving ducks in a gallery. You can slide to either side while still standing on the door to avoid being hit. You can also simply run inside and swing to either angle of the room to find shelter, only to swing out into an angle where you get a good look at the target.

Once you dispose of the Imps in this manner, run to either corner of the room. Either way you will set off one of the twin triggers t4. By doing that, you will release a few Cacodemons into the open. While the Cacodemons float across the landscape to catch up with you, continue moving forward and take the rest of the building. On the northwest side, after climbing the stairs, you will run into a few Medikits and a box of shells. Restore your health if you need to and grab the shells; you might need a good many of them. If you do this fast enough and just happen to have a rocket launcher or another heavy weapon from the previous level, you might want to run out and take on at least one or two Cacodemons before they chase you in.

Run back inside and climb to the northeast area of the three-chambered building. Before long, the Cacodemons will arrive. With the Cacodemons with you inside the building, you are relatively safe. However, while they cannot reach you, they can still fire at you any time you show your face, and show your face you must if you wish to kill them. Jump out from either corner and concentrate your efforts on a single Cacodemon. But be sure to step out of the way of incoming lightning balls. You might start out inflicting wounds using your shotgun. After they are softened a bit, switch to the rapid fire of the chaingun.

Reaching the secret exit: To accomplish this maneuver, you must possess all the armor and health you can stand. You also need to have the rocket launcher in your possession and at least one rocket. Perhaps knowing what you need to have will give you an inkling as to what it is you must do to reach the secret exit and explore the secret level. As you might have surmised, the secret door to this level is the small blue well at the north end of Mount Erebus. Inside the well is a switch that you must activate.

The only way you can see the switch inside the blue well is by standing on the narrow ledge that overlooks the entire northern panorama. To reach this ledge, you must ride teleporter T11 from inside the green room at the north end of the central installations.

Once you are on the ledge, you have absolutely no room for a run into the well. You must devise another plan. Walk easternly as carefully as possible. (One false step and you will plummet to the blue ooze below.) When you find yourself directly south of the blue well, turn to face the wall—your back towards the well. Then pull out the rocket launcher. You will use its explosive power to propel you backwards across the distance which is otherwise inaccessible. If you want to align yourself perfectly, use the computer map. (Some might want to execute the entire maneuver while viewing the Automap.) If not well armored and healthy, you stand to sustain serious damage. If you land in the well alive, turn around and throw the switch. You are on your way to Warrens, the secret level. Au revoir.

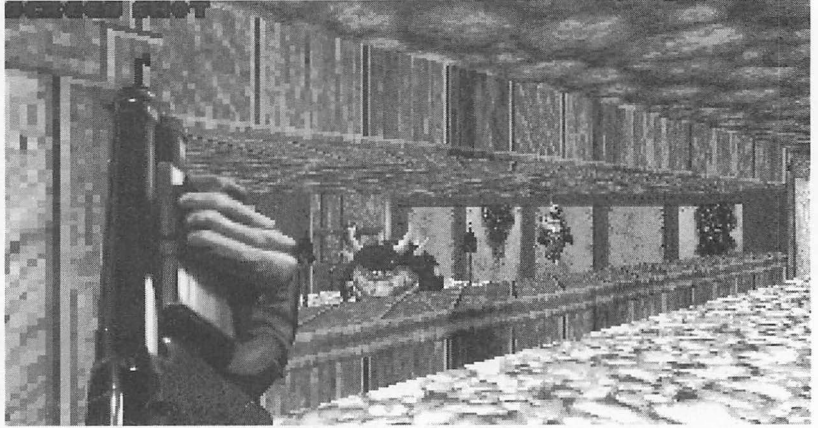

UNCOVERING THE SECRETS OF MOUNT EREBUS

Switches s1 and s2 are inside the small square room at the east end of the installation, in the middle of the lava. Both switches open doors inside the room, behind which you can get a radiation suit and a shell box. However, there will be a few monsters behind each door as well, including a Cacodemon. Along the northeast of this room you will find a backpack.

This room is also interesting in that it has an unmarked teleporter that behaves quite uniquely. If you enter the room very slowly, you will notice the protruding jaw of a Demon standing by the north wall. The Demon happens to be standing at the precise location of the peculiar teleporter, T2. As soon as he spots you and charges after you, the Demon will be instantly teleported to the opposite side of the room. Where an instant ago he was charging you from the right side, now he's coming at you from the left. But you too can play the same trick. Run away from the Demon and race toward the invisible teleporter. Then try to run westward. You will flash across the room and can now pelt the Demon from a safer distance.

Twin triggers t4 are found on either side of the three-chambered building. Tripping either one opens door d4 at the south end of the installation, releasing a contingent of Cacodemons. There is a Combat Armor to be had back there.

Trigger t5 crosses the middle of the horseshoe shape structure near the middle of Mount Erebus. You will be lured to cross the trigger by the sight of the Security Armor and shells sitting there. Crossing t5 will cause twin secret doors d5 to raise. Behind the northernmost d5 there is an Invulnerability artifact, but also a posse of Imps. The southern d5 is a containment area for Lost Souls. In effect, crossing t5 makes you the center meat of a monster sandwich.

Even though you are outnumbered and flanked from both sides, you will want to charge the Imps to get the Invulnerability artifact. It only makes sense to be impervious to damage when you know harm and hurt are all around you. Use the rocket launcher and a steady stream of rockets to clear

the way until you reach the artifact. You can then await the arrival of the Lost Souls and greet them with a variety of firepower.

The small green building with the frontal set of stairsteps, near the northeast of the paved area, contains two teleporters, T6 and T7. You will do well to reach for the chainsaw as you jump into the sunken floor of this building to be ready for the Specters waiting inside. T6 along the east side will transport you to the north end of the building's exterior. You will find yourself standing on the elevated north end of the building with a case of shells in front of you.

Taking teleporter T7, on the west side of the room, also puts you outside to the north end of the building, but on the northeast side. A step or two away from you, there is a bulk cell and a plasma rifle.

By climbing off the building, you will cross trigger t8 and thus open the doors to secret door d8, just across the way and a short distance into the lava. From this door will emerge another set of Cacodemons. There is also a radiation suit behind that door.

Teleporter T9A is found at the north end of Mount Erebus. To reach this teleporter, you will have to race across the lava and fall into a curious liquid blue ooze with no apparent harmful effects. Riding teleporter T9A will put you at the entrance of the large green building near the north end of the paved area, at the spot marked A on our map. Having teleported here, you have avoided crossing trigger t10.

Trigger t10 opens the gates of secret door d10 at the northeast corner, a short distance into the lava. There are oodles of Lost Souls and a single radiation suit behind that door.

Teleporter T11B is found inside the green room. Also in this room you will find a bulk cell behind secret door da (along the north side of the room behind the black candle). A Berserk Pack is also up for grabs near the back end of the room. Teleporter T11B is found behind secret door db, just at the opposite side from door da, and also behind a black candle.

Ride teleporter T11B and emerge standing on a small ledge overlooking the blue ooze at the north end of Mount Erebus. From this perspective you have a few options. First, you can jump onto the pillar just east of your location and grab the chainsaw sitting there. Secondly, you can jump into a red well where another teleporter, T12C, awaits. Finally, you

can try to make it into the blue well to reach its well-guarded secret. But this third task will require you to come up with a plan for maximizing the distance you can move.

Teleporter T12C places you in the oddly shaped building with three narrow wings at the northwest end of the installation. Taking one or two steps inside from your entry point will activate trigger t13. This trigger will open the secret door d13 and release yet a few more Cacodemons.

The south wing of the narrow building contains the blue skull key you need to exit the level. To open a door and leave the narrow building, you will have to activate switch s14 at the west wing. This will cause a small door to open just behind the place where you materialized. As you leave the building, you will activate a small trigger, t15, and release more Cacodemons from a small enclosure near the passage to the final exit. There is a Soul Sphere behind door d15.

The southeast end of the installation has a yard with perhaps the largest concentration of monsters in the level. In the midst of all the monsters is a platform where you can nab a shotgun, a rocket launcher, a chaingun, and a rocket case. You can also jump from the stairs on the east side and land almost right on top of an Invulnerability artifact.

On the south ridge of Mount Erebus is a small platform that projects onto the lava and is connected to the solid area by a narrow walkway. On top of this platform you will find a rocket, a shell box, an ammo box, and a rocket case. If you approach this platform using the narrow walkway, you will set off trigger t16 and thus cause the walkway to disappear into the lava behind you.

LIMBO

Contemporary definitions of Limbo cite a region or condition of oblivion or neglect. In its Roman Catholic origins, Limbo was borrowed from the Latin *limbus*, meaning "fringe" or "border," to denote a place just this side of Hell. Souls excluded from the beatific vision but not condemned to further punishment, according to the Catholic church, are said to inhabit Limbo eternally. Limbo is definitely not a place you want to be, for it is not a place at all but a perpetual condition.

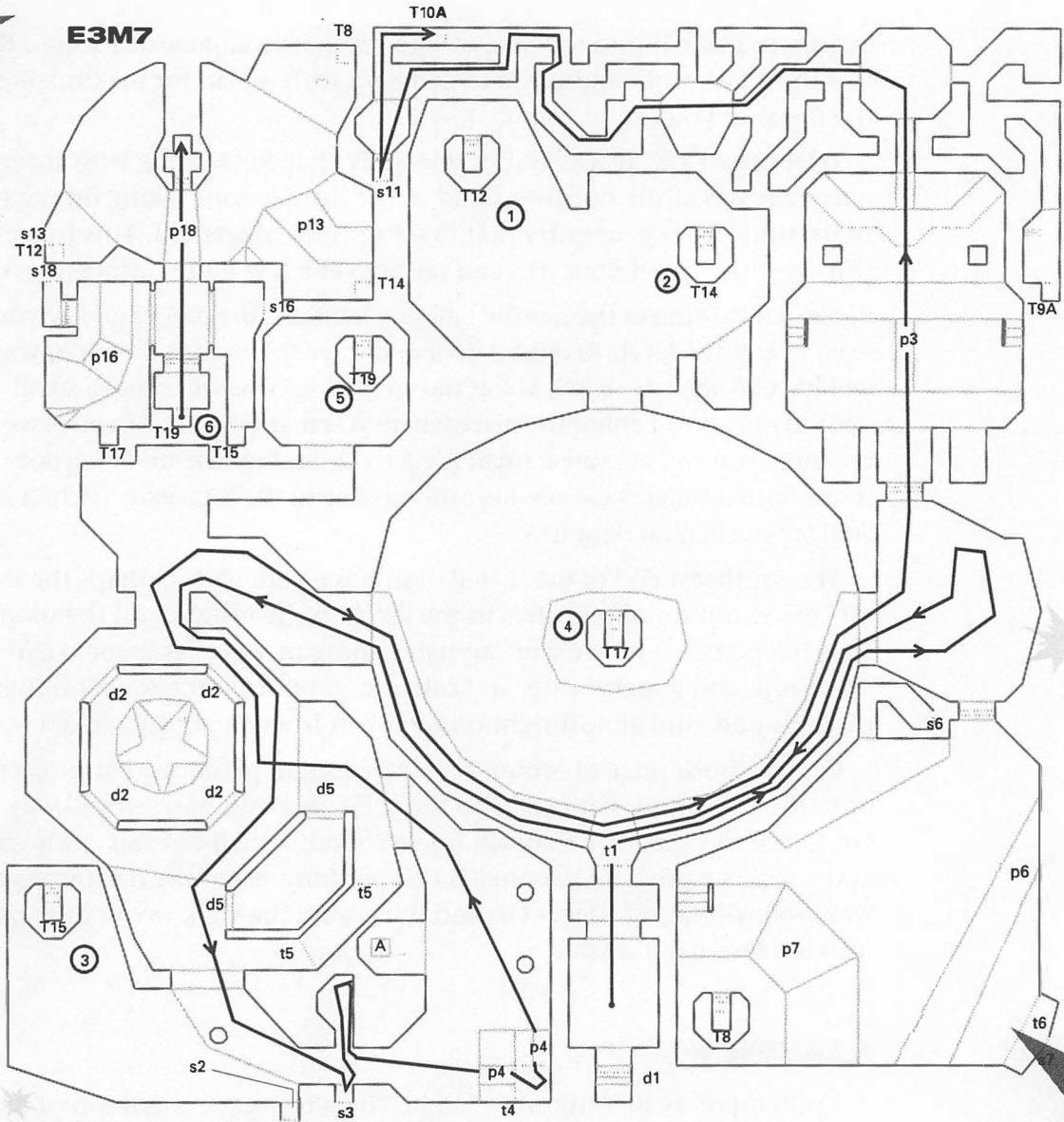

FIGURE 6.7A LIMBO BLUEPRINTS. *Ideal route map, indicating triggers and switches.*

In Doom, Limbo appears roughly square, its distinctive structures consisting of a good number of irregular shapes arranged around a huge, central, oblong room carpeted in lava. The top part of this structure is also

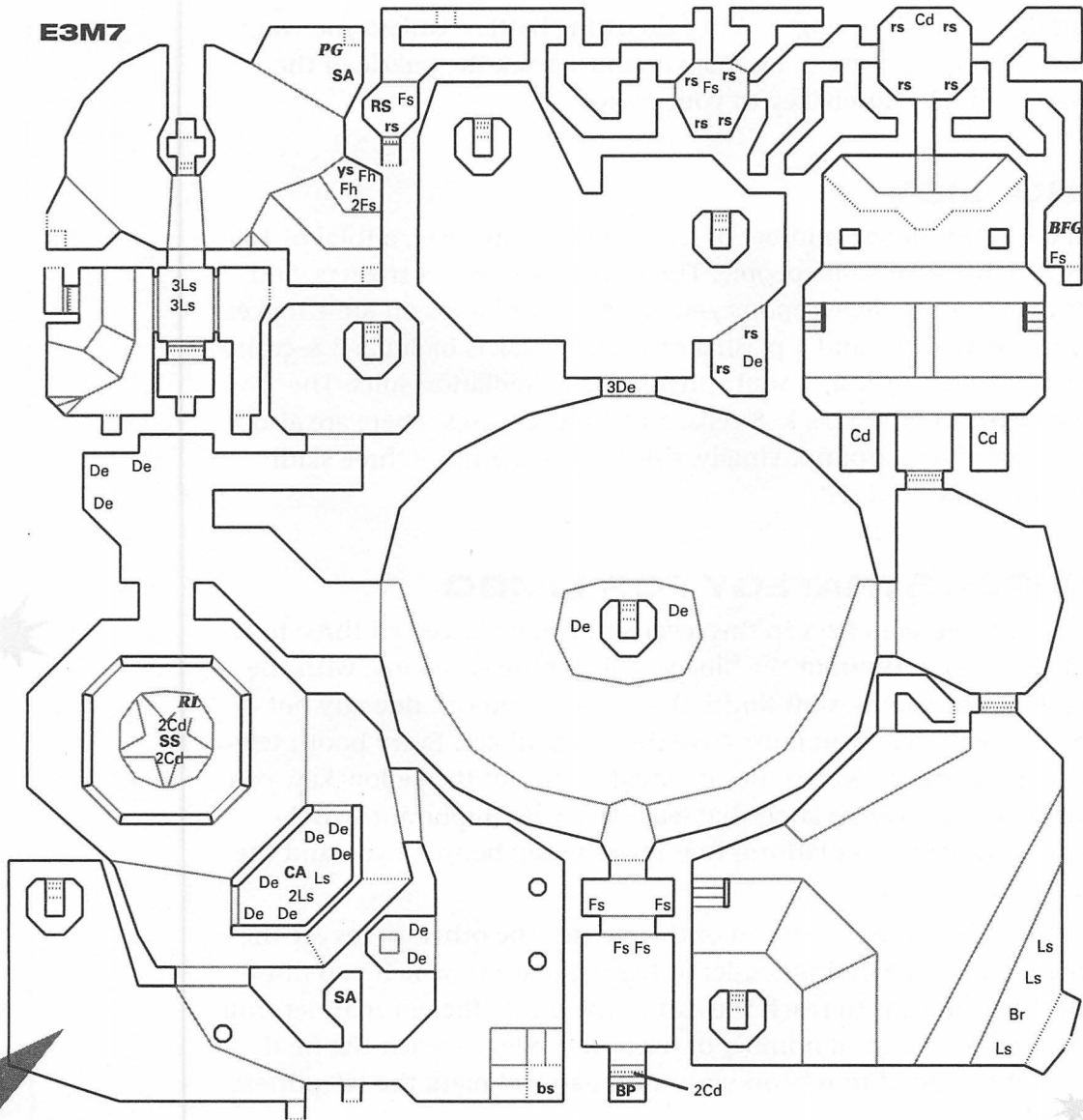

FIGURE 6.7B LIMBO BLUEPRINTS. Monsters, weapons, and artifacts map.

connected through a harmful network of maze-like passageways. Speckled with a good number of teleporters, Limbo's squalid architecture and endless trappings will have you on the edge of screaming. * *

Naturally, you will be engaged in exhausting battles. Unless you want to spend eternity fighting in Limbo, you must crack the puzzle of the teleporters. It is absolutely key to your escape.

LIMBO: LIST

Limbo has the largest number of teleporters of any level, a total of 13. A lucky number—for some people. There are 8 switches, 4 triggers, and 8 platforms. Among the weapons you can get your hands on are 1 rocket launcher, 1 BFG 9000, and 1 plasma rifle. The artifacts include: 2 Security Armors, 1 Combat Armor, 1 Soul Sphere, and 11 radiation suits. The ammo consists of 1 backpack, 8 cells, and 2 rocket cases. There are also a few shell cases lying around. Finally, this level contains all three skull keys: yellow, blue, and red.

GENERAL STRATEGY FOR LIMBO

There are three skull keys in this level and you will need all three to make it to the exit. Without the blue key, the entire east wing, with the exception of one room, is off-limits. Also, before you can ride any but a handful of teleporters, you must have the red skull key. Every booth teleporter in this installation requires it. Finally, without the yellow key, you will not be able to open a latch that leads to a very important switch—the switch that causes a platform to bridge the gap between you and the exit in the final room.

But the keys are only a portion of the puzzle. The other pieces are the teleporters. There is a definite order to the sequence in which you must take them if you want to reach the exit in the most efficient manner. You will have to go on a good number of teleporter rides to reach the final exit. It might be good to rely on your Automap and mark the teleporters you have been to.

The battle scenario in Limbo is tough and turbulent. There are moments when you can pause for a second and figure your next move, but, for the most part, you will have to react instantly and guard against the usual cast of enemies.

STEP BY STEP THROUGH LIMBO

Liberation and subsequent destruction of the monsters in the southwest corner of Limbo: You can simply activate switch s3 to raise a crucial platform near the northeast corner of the structure. You can also activate switch s2 and unlock the four secret doors surrounding the pentagram room (located north of the switch) to reveal some valuable rewards—a case of rockets, a rocket launcher, and a Soul Sphere. However, you will also be releasing a few quarrelsome Cacodemons.

There is also another secret room just southeast of the pentagram room. If you enter this room, you can avoid releasing a horde of Demons and Lost Souls by avoiding twin triggers t5 behind the secret room, but you will also be passing up a Combat Armor and a single rocket. If you need these items, release the monsters one room at a time and deal with them before turning to the next room. Your strategy will be to lure the monsters to follow you toward the southeast corner, where the blue skull key is found. Once you get a good angle around a narrow passage, turn around and face the monsters with a shower of rockets, bullets, or plasma discharges.

The pentagram room offers the most incentives, so start there. Punch switch s2 and head toward the pentagram room as you reach for your rocket launcher or plasma rifle. Approach slowly at first. The Cacodemons won't move until they notice you. But once they do, you can count on a lightning-ball downpour. If you can, sneak one or two rockets deep into the spongy flesh of the first Cacodemon. Then run out of sight. If you can, run backwards and continue releasing rockets into these trailing gruesome levitating tomatoes. Your best position to defend yourself is where you are about level with switch s3. You can run slightly forward to deliver more punishment and then quickly run backwards to avoid the thunderous balls.

Having snuffed the last Cacodemon, race back into the pentagram and grab the Soul Sphere, rocket case, and rocket launcher.

Cracking the teleporters and reaching the exit: There are quite a few teleporters in this level and you can literally spend hours looking for the right combinations that will get you to the exit. But many teleporters are in the middle of large pools of ooze, and there are only a limited number of radiation suits. So you must attempt to reach the exit most expeditiously. To accomplish that, you must go through the teleporters in a certain order. Also, almost every teleporter in this level requires you to have the red skull key to



open it. So, if you haven't gotten the red skull key, go in search of it. (Incidentally, switch s11 causes all teleporters with a red door to open, thus precluding any need for the red skull key. This is somewhat ironic because, after all, the red skull key sits a few feet *in front of* switch s11.)

Don a radiation suit and enter teleporter T12 first. Emerge at the small cave-like room above a large circular ooze pit. Throw switch s13 right beside the teleporter to raise platform p13 across the ooze in the northeast corner of this area. You should be able to see the glowing yellow key from where you stand. Return to teleporter T12. Run out and into teleporter T14. You materialize at the southeast corner of the area of caves surrounding the green ooze pit. Run across platform p13 and grab the yellow skull key and the cell lying there. Retreat into the teleporter. Come out and grab another radiation suit if you need it.

Race all the way to the southeast corner of Limbo. Cross the ooze and enter teleporter T15. You are transported to a narrow and short hall flanking the right side of the room leading to the final exit. Run forward and throw switch s16. It raises a platform in the room flanking the west side of the exit. You will need to traverse this platform to throw another switch to bridge the gap between the exit and the narrow room leading to it.

Jump back into teleporter T15. Come out at the southwest end and run back to the central lava-filled room. Ride the teleporter at the room's very center, T17. Watch yourself emerge in the room with platform p16. Cross it and push past the yellow door. Then slam switch s18. This will raise platform p18 out of the green ooze, effectively closing the gap between the narrow central room leading to the exit.

Your last task is to reach the central hall that leads out of Limbo. For that, run back into the teleporter. Spring out in the central lava sphere area and head back toward the final teleporter, T19, almost directly northwest of the central teleporter (T17). Cross the last bit of ooze and enter T19. Come out in the central hallway east of T19. You are but a few skips from the exit. Goodbye Limbo. Hello Hell.

UNCOVERING LIMBO'S SECRETS

The first trigger, t1, is just north of your initial entry point, at the threshold of the circular and centrally located lava sphere. This trigger causes d1, located right behind your entry point, to rise. Incidentally, this door can also simply be pushed open. Behind d1 is a backpack. In the harder levels you will also uncork a couple of Cacodemons from this door.

Switch s2 is found along the wall of the southwest area, wedged in a wall recess, behind a small, but deadly, puddle of red ooze. This switch opens a set of four doors, d2, surrounding the pentagram room. You can expect a few Cacodemons to come bouncing out. There is a rocket launcher, a rocket case, and a Soul Sphere inside, on top of the pentagram.

Switch s3 is found just east of switch s2. Switch s3 opens a crucial platform, p3, at the northeast corner of the installation. This platform will allow you to cross over and have access to the northern ooze-maze zone.

Perimeter trigger t4 surrounds the blue skull key at the southeast corner of the room east of switch s3. Crossing it lowers the platforms over the small ooze puddle framing the blue skull key.

Twin triggers t5 are located at the back side of the secret room southeast of the pentagram. Crossing either one opens twin doors d5 at opposite sides of the secret room. Inside the room are various Lost Souls and Demons. The room also holds a Combat Armor and a single rocket.

Switch s6 is in the north end of the large pebble-floored room at the southeast end of Limbo. To reach the switch you have to enter the small red hallway behind the platform to your right as you enter. Throwing this switch causes a large diagonal wall at the southeast corner of the room to lower temporarily. If you are playing in Ultra-Violence mode, you will see a Baron of Hell descending with the wall. Behind this wall you will find a couple of cells and switch s7.

Switch s7 raises a platform across the ooze moat surrounding teleporter T8 at the southwest corner of the room. As you head back toward the wall (which should be raised by now) you will activate trigger t6 and cause the wall to lower again. Crossing platform p7 you will run into teleporter T8, and also find a cell behind it.

The next set of secrets are found along the red maze at the northeast end. The square room near the northeast corner contains four radiation suits. You are about to run around in pernicious red ooze, so be sure to wear a suit at all times. Southeast of the square room with suits you will run into a small platform where a Former Human Sergeant guards the BFG 9000. Behind the BFG, you will find teleporter T9A. This teleporter sends you to location A, near the southwest corner of the installation.

East of the square radiation-suit room, a similar but more irregularly shaped room contains four more radiation suits. Grab another one and continue heading west. At the very southwest corner and end of the red maze, you will come upon the red skull key and switch s11. Grab the red key to gain access to all the red door teleporters. Throwing switch s11 also gives you access to red teleporters, as activating it causes every booth teleporter to open its door. Near the northwest end of the ooze canal, you can jump into teleporter T10A. This teleporter puts you back in location A, near the southwest corner of Limbo.

Teleporter T12 sends you to a cave above a large circular ooze pit. From this location you should be able to discern a yellow skull flashing across the pit—and also the final exit, right smack in the center of the pit. Switch s13 is just north of T12. Throw this switch to cause platform p13 to emerge from the ooze in the room east of your location over the ooze pit.

Trigger T14, located southeast of T13, takes you to the room where p13 was raised a few seconds ago. Running across p13, you will be able to grab the yellow key and a cell.

Teleporter T15 takes you to a narrow room on the right side of the hallway that leads to the final exit. At the northeast corner of this room, switch s16 causes platform p16 to appear and bridge a gap across an ooze pit in the room at the far west side. This platform allows you to reach a yellow door, behind which is a crucial switch to make your exit possible. Teleporter T17 is found at the very center of the red lava room. Ride this teleporter to reach the room where platform p16 was raised.

Once in this area, walk over p16, past the yellow door, and throw switch s18. This last switch will raise a narrow platform, thereby linking the exiting hall and the actual exit.

Finally, access the central exiting room by riding teleporter T19 northeast of the central teleporter (T17). Once in the central exiting room, grab the cells to either side of you and then run across platform p18 to touch the exit.

DIS

Offering perhaps the simplest design of all 27 of Doom's levels, Dis is it, the final level of Inferno. Gone are the mind-twisting architectural surprises—not a single switch to break the otherwise smooth polished look of every Dis surface. Why there's not even a slimy ooze barrel. The ultimate in cold efficiency and cruel functionality, Dis is the closest thing to an infernal version of the Roman Colosseum.

In Dis you are a future-day gladiator pitted against a couple of Cacodemons and the aberrant ruler of Inferno, the Spider Mastermind itself. If you play in the harder difficulty levels, you also get to exchange amenities with the socially inept Baron of Hell. They and you are the protagonists of what might well be a battle of epic proportions. The sparse and low profile of the installation requires only a general explanation of your strategy. But first, study the map of Dis for a few seconds. Because of its relative simplicity, this map reveals monster and artifact locations as well as the installation blueprint.

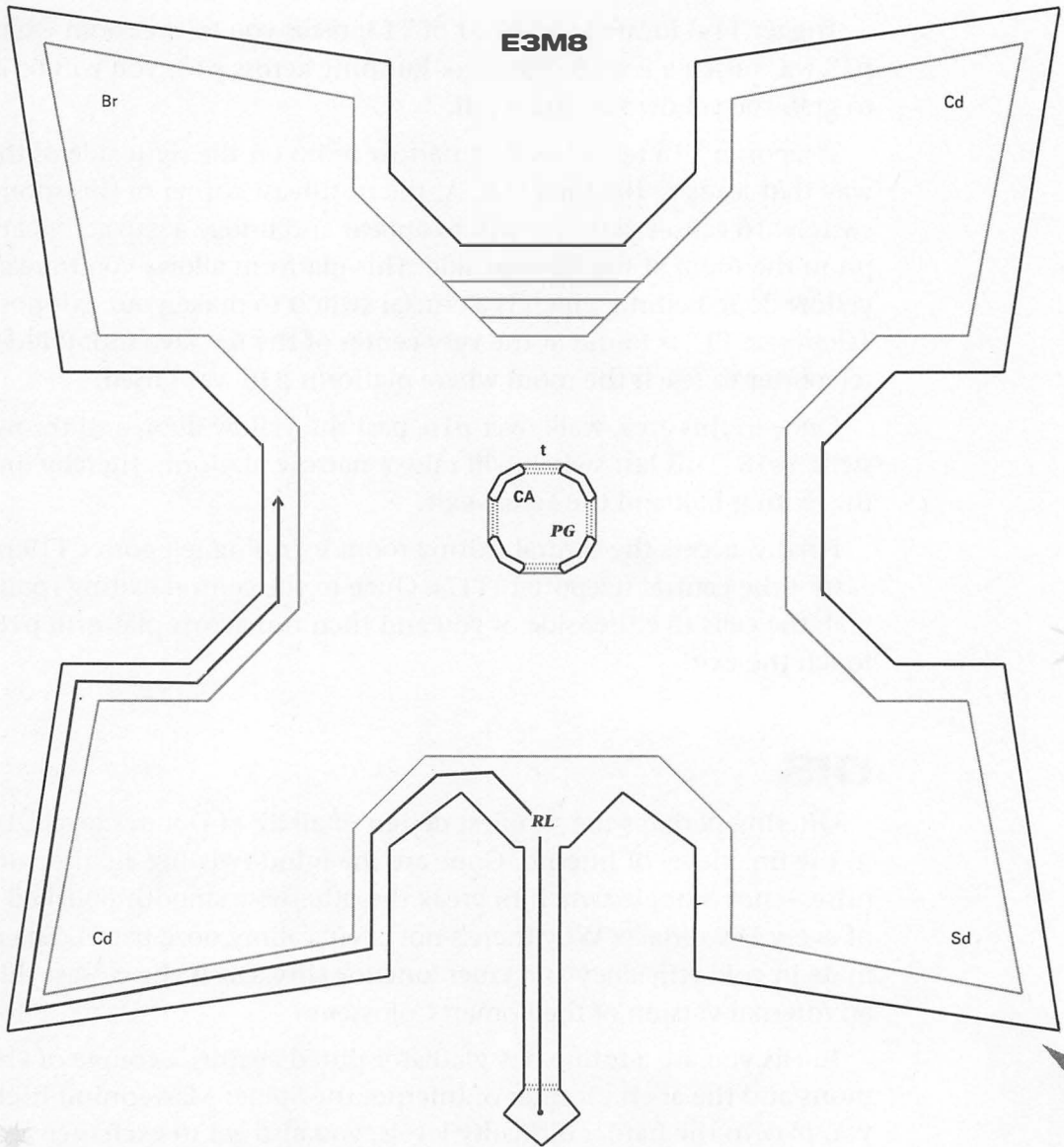

FIGURE 6.8 *DIS BLUEPRINT.* Combination ideal route, monster, and powerups map.

GENERAL STRATEGY FOR DIS

A cursory examination of the map, reveals that every corner of the structure may contain a monster—depending on the level of difficulty.

By far the worst of them is the frightening Spider Mastermind, at the southeast corner of Dis. The map also shows a central room that might well serve to shield you from the Spider's ultra-fast chaingun. Notice, too, that the central room is flanked by four doors. Inside is a Combat Armor and a plasma rifle. Given these conditions, and knowing what you know about monster psychology, your strategy for succeeding in this level is amazingly simple—at least in theory. Executing your strategy, however, is entirely another matter.

In brief, you should attempt to pit the monsters against each other. If you can get the Spider Mastermind to tango with one or two Cacodemons, you can then creep up its back and deliver a fulminating BFG 9000 blast. It will take three full impacts to bag the Spider. Can you rise to the occasion? You haven't come this far to vacillate.

If you don't have a BFG 9000 as you enter this level, you can still succeed if you manage to cling to life long enough. There are a good number of rockets situated around the periphery of the structure to let you have a fighting chance.

You begin this level in the one and only corridor at the south end of the structure. As you emerge into the vast open courtyard, you will run into a rocket launcher. Take it and proceed left along the perimeter of the structure. You are in effect getting some distance between you and the Spider Mastermind. You hope that as it sets off in your pursuit, it will engage in battle with any Cacodemon standing in its path. You basically have a few seconds before all hell cracks loose.

As you head westward, pick up every rocket on the run. Avoid falling below into the courtyard. (The only way to climb back up is to use the stairs at the north end of Dis.) Around the second bend, near the southwest corner, you will come into full view of a rousing Cacodemon. Continue running and avoid the lighting balls. When you get a good angle, unload two rockets in quick succession to stop the Cacodemon cold. Continue running and collecting rockets. As you reach the midpoint of the structure, just east of the central kiosk, the Spider Mastermind will enter your peripheral field of vision. (You must avoid at all costs staring the Spider Mastermind in the face. Nothing personal. It's just that ultra-speed chaingun that the Spider has for a mouth; you don't want to stand

for more than an instant in front of it. You could be reduced to a flaccid sack of lead in less than ten seconds.)

Jump off the platform and head toward the kiosk. Circle around its north side and switch to the BFG 9000. With any luck the Cacodemon and the Spider will be locked in mortal combat. Run behind the Spider to where you can unload the slow discharge of the BFG 9000. It is likely that you will only be able to deliver one discharge before the Spider retaliates with a curtain of bullets that can actually buffet you around as much as they penetrate your armor.

Until everyone drops dead, you and any monsters left to you will perform a violent, unchoreographed adaptation of the Mexican hat dance, with the kiosk at the center. If there are any remaining Cacodemons or if the Baron is loose (in Ultra Violence and Nightmare there will be a Baron), pound them with the appropriate amount of rockets.

Depending on how facile you are at moving, you might want to open the kiosk doors. The second you step into any door you open, a trigger causes the other three doors to open as well—and remain open. By opening the doors, you have additional opportunities to aim your weapon at the Spider. You can also cut across through the kiosk and change positions quickly. But, unfortunately, you are also now more available as a target for the trigger happy Mastermind.

After connecting the third BFG 9000 blast or the last rocket in a sequence of fifteen, the Spider will be crushed under the weight of your will and even stronger mind. Hell is at last behind you. Earth is in front of you. Welcome back. We've been waiting.

WARRENS

Hello again. If you are reading this, you have reached Inferno's secret level. But don't expect a medal. There are no known heroes in Hell. (Could you be the first?) Warrens will throw you for a temporal loop. As you begin to explore this structure, everything will seem so familiar, and yet...Wait a minute. This can't be happening!

Sorry, but there is no rest for the wretched in Inferno. And no, you are not hallucinating. Hell hasn't warped your mind completely. Not yet, anyway.

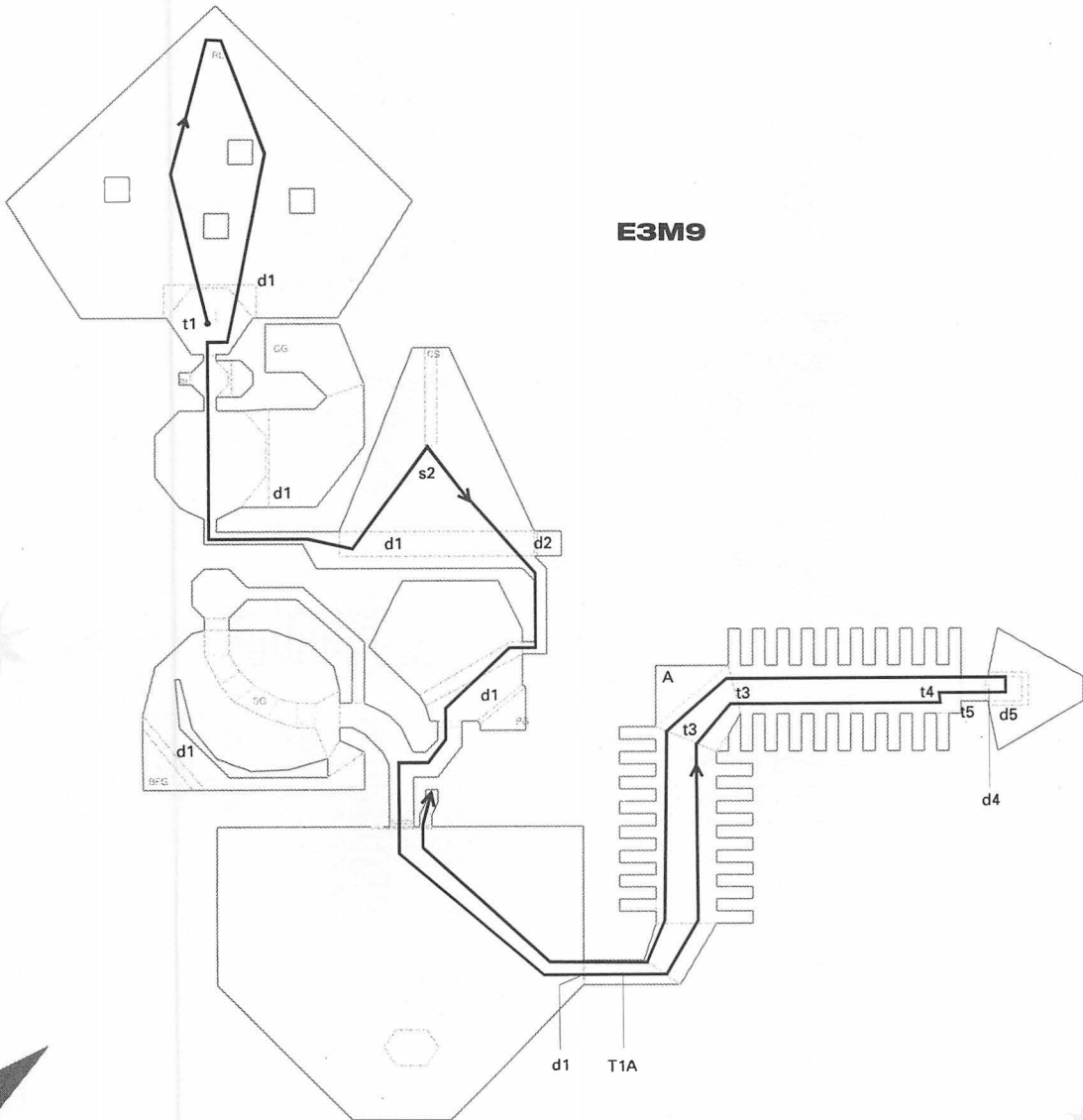

FIGURE 6.9A WARRENS BLUEPRINTS. *Ideal route map, indicating triggers and switches.*

Warrens might seem like a complete replica of Hell Keep. But you cleared Hell Keep what might seem like eons ago. Is this someone's depraved idea of a practical joke? Is there room for cruel humor even in Hell?

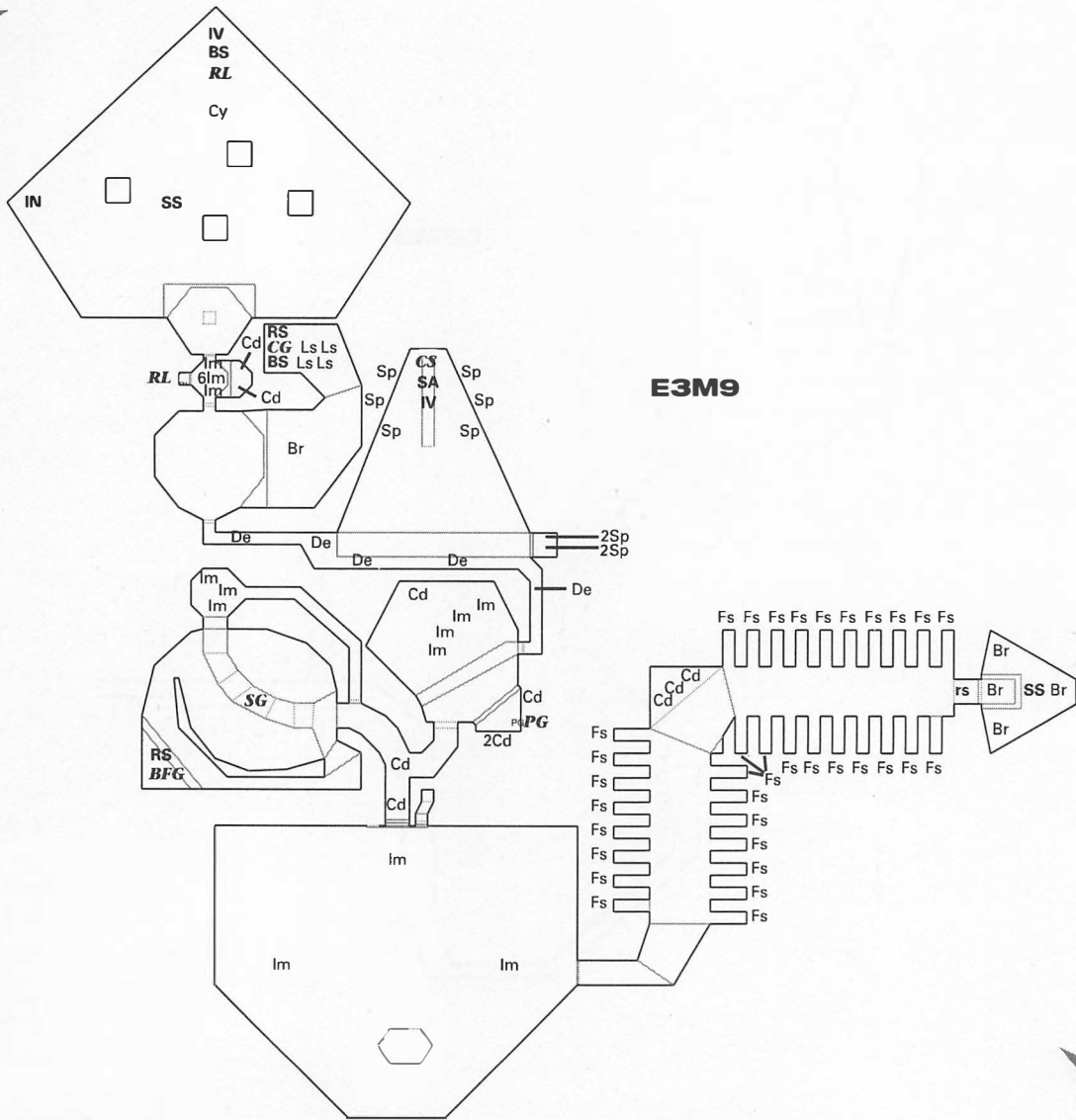

FIGURE 6.9B WARRENS BLUEPRINTS. *Monsters, weapons, and artifacts map.*

When you reach the exit for what looks and feels like Hell Keep, your journey will have just begun. Walls will drop all around you, changing the face of the landscape. You will know then that the tougher leg of your odyssey is just a step away. The new additions to the installation

bring you into contact with not-quite-forgotten acquaintances—Demons, Cacodemons, Lost Souls, Imps, and Specters. And making an unexpected appearance, who could ever forget Cyberdemon?

WARRENS: LIST

We won't enumerate all the secrets that you find on the first part of this level. They are exactly the same as those you found in Hell Keep. But, having reached the exit, you can expect to uncover many more. Among them are the following: 1 switch, 4 triggers, and 1 teleporter. The weapons include: 1 rocket launcher, 1 chaingun, 1 chainsaw, 1 plasma rifle, and 1 BFG 9000. The powerups consist of: 1 Invisibility Blur, 2 Invulnerability artifacts, 1 Berserk Pack, 1 Security Armor, 1 Soul Sphere, and 2 radiation suits.

GENERAL STRATEGY FOR WARRENS

Do you know how to pray? It might not hurt. But even without a helping hand from above, a tough and smart player *can* escape from Warrens. After completing the first part of this disorienting level, you basically set a stage for a bruising battle that might not last more than a couple of acts. Finding the exit of this level requires you to go back to the initial entry courtyard. There you must open a door requiring the red skull key. But your immediate predicament is to grab a blue skull key and escape the relentless arm of the Cyberdemon.

As you work your way back to the courtyard, you must face a Baron of Hell, various Cacodemons, and a fraternity of Specters. Throw in a few Lost Souls and you have a lethal monster salad. Once you reach the outside, you must teleport into the heavily guarded corridor east of the courtyard. There you will have to wrestle for the red skull key and face off a fearsome foursome of hellish Barons.

Under such conditions, you can only plan so far. At some point the forces will collide and the stronger will prevail. But there is still much you can do to help your cause. For one, grab key powerups at the right moment. For instance, at the north end of the structure, you must face the Cyberdemon. To stand any chance, you must load up with rockets, secure the Blur Artifact, and then go for the Invulnerability artifact.

As a last piece of advice, remember that you will be facing as many as five Barons of Hell. This means that you must pack as many rockets as you possibly can.

STEP BY STEP THROUGH WARRENS

Busting the Cyberdemon: Your main concern after reaching the teleporter at the north end of the installation is to overcome the monstrous Cyberdemon and his rocket-spewing, unrelenting mechanical arm. Taking your first step from the teleporter, you will set off a trigger and cause various walls to drop around the installation. One such wall opens a large courtyard at the north end of Warrens. Behind the northernmost pillar sits the imposing figure of the Cyberdemon.

The recommended course of action is for you to grab all the rocket cases you can and then run to the northwest corner of the courtyard where you can grab a Blur Artifact and veil your presence right away. Then proceed to the north point of the courtyard. Grab the blue skull key (which allows you to leave the courtyard), the rocket launcher, and, very importantly, the Invulnerability artifact.

Use every second of your Invulnerability. Face the Cyberdemon squarely and pound him fast and hard. Weather any rockets that he connects with. They might push you back but they won't hurt you as long as you are invulnerable. If your Invulnerability starts to wane and the Cyberdemon is still standing, use the large pillars around the room as shields and continue popping the Cyberdemon as you sidestep away from his line of fire. Hit the Cyberdemon at least twenty times and watch him crumble.

UNCOVERING WARRENS' SECRETS

Taking a step in any direction from the teleporter at the north end brings down a number of walls as you trip trigger t1. A total of five walls and doors, designated on the map as d1, will sink into the ground. This will reveal additional installation rooms, monsters, and other secrets.

The courtyard north of trigger t1 houses the Cyberdemon and a few powerups and weapons. Among them are Invulnerability and invisibility artifacts, a rocket launcher, and the blue skull key.

In the second chamber south from trigger t1, a Baron of Hell eagerly awaits you. By going through the red ooze and circling around the north-east corner of this chamber, you will run into a chaingun, a radiation suit, and a Berserk Pack. With the exception of the radiation suit, you should grab everything. It will come in handy later when you reach the red ooze chamber (where the collapsed bridge lies useless).

Switch s2 is found near the north end of the triangular room north of what once was a very narrow hall. This room is a Specter hangout. So go in cautiously and launch a few rockets or plasma blasts in lieu of a calling card. Switch s2 opens the very narrow door behind it. Inside you will find a chainsaw, a Security Armor, and an Invulnerability artifact. The same switch also opens a small chamber at the southeast corner of the triangular room, releasing another cadre of Specters to keep you in good cheer.

South of the triangular room, you will access a small outside area. But now you will be in the ungratifying company of Cacodemons. Blow the air from these insufferable hovering beasts. Then tail it back to grab the radiation suit near the north end of the installation. Around the ooze corridor in the room with the collapsed bridge, you will come upon another radiation suit and a BFG 9000.

Once out in the courtyard, you will notice a narrow opening to the east along the wall. When you enter this area, you are immediately teleported by unseen teleporter TA to the area labeled A, at the intersection of two tooth-comb corridors. You will emerge behind a group of Cacodemons. Both corridors are heavily guarded by an army of Former Humans and Sergeants, who are presently reposing between each "tooth" of the tooth-comb hallway. Come out firing when you are ready. The chaingun or the plasma rifle are good bets here. (Save the BFG 9000 and the rockets for the Barons in your future.)

When you get a moment, take advantage of the large number of recesses in the corridors by hiding inside a narrow tooth. As you move into either hallway, you will set off trigger t3, causing all the lights to dim. It

is highly likely that the monsters will start a good old-fashioned bar-room brawl in the ensuing confusion. From the relative safety of your narrow location, pepper anyone that comes in your direction. When things die out a bit, emerge and deal with any standing opposition.

At the far east end of the hallway, as you get nearer, you will see the glowing red skull key. In reaching to grab it, you will activate trigger t4, causing secret door d4 in front of you to lower and reveal a Baron of Hell in all of his majestic countenance. Before reaching for the red skull key, you should pull out the BFG 9000 and make quick work of the Baron. If you prefer, prepare to run backwards as you unload a steady stream of rockets.

If you've managed to put the Baron away, you will notice a bulk cell behind the place where the Baron once stood. Trigger t5 is right in front of the bulk cell. If you cross it, the walls around the cell will drop and place you in the middle of a Baron trio. Lucky for you, you have just reloaded the BFG 9000. So put it to good use.

Emerging from the tooth-comb hallways, head north toward the gate. Push open the red door and step inside to ride the final teleporter out of Warrens—and back to Hell.

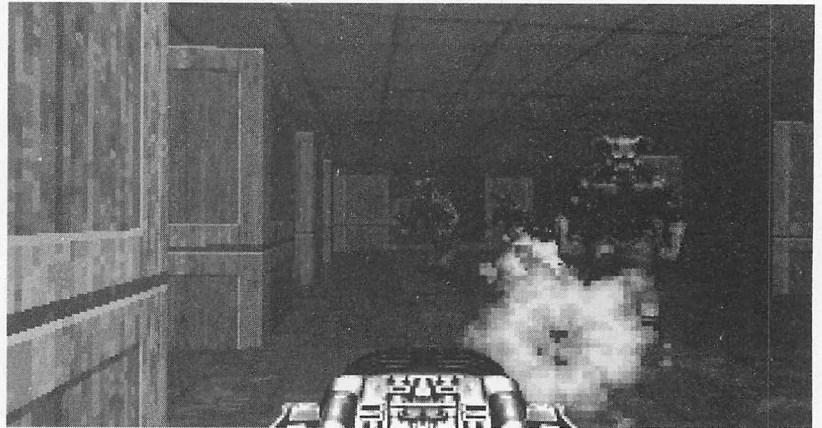

PART THREE

**INTELLIGENCE
BRIEFING**

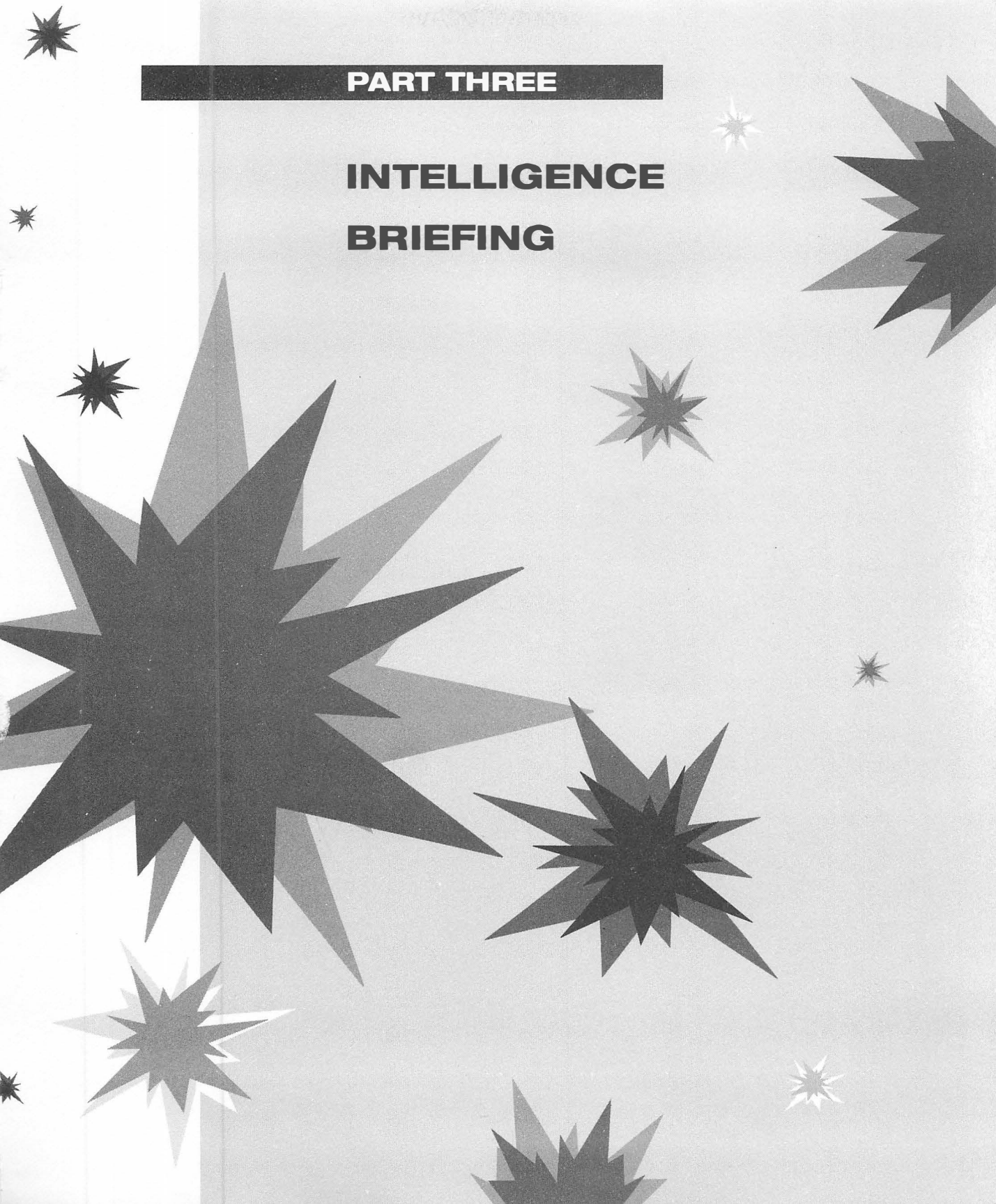



**DOOM IN
MULTIPLAYER
MODE**

S E V E N

Back in Chapter 3, you learned about some basic MultiPlayer strategies. This chapter focuses on the basic operation and control of multiplayer. It tells you what the new rules are (in both Cooperative and Deathmatch modes) and also covers your new controls and options. Additionally, it explains how to play over a network, through a modem, or through the Internet.

But before getting into all that, you should know the fundamental stuff:

- Playing the full (mail-order) version of Doom requires each player to have a licensed copy of Doom. To play the shareware version, it is not necessary to have individual licenses.
- During MultiPlayer mode, each player wears a different color uniform. Your color is indicated by the background behind the marine's mug. The available colors are: brown, indigo, green, and red.
- If a player dies during Deathmatch, the play continues for all surviving players. The dead player can spawn (reemerge) after a few seconds in a random location by pressing the spacebar. Any monsters that have been killed and any ammo that has been used up will not reappear when a dead player spawns.
- It is possible to broadcast general messages and to direct them to a specific player. A nifty macro option lets you send prerecorded messages too.

FRIEND OR FOE: DEATHMATCH VS. COOPERATIVE PLAY

The first choice to make in MultiPlayer mode is choosing between Cooperative or Deathmatch play. This section points out the differences with regard to your initial location, the weapons and keys, the Status Bar, the Automap, the Spy mode, and the game's tallies.

INITIAL ENTRY LOCATION

In Cooperative play, you and your buddies enter a level in the same area. In Deathmatch play, everyone enters in different locations.

WEAPONS AND KEYS

In both modes, the weapons are inexhaustible. You can pick up any weapon, but a clone remains in its location for others to grab. With keys, it's a different story. In Cooperative play, after grabbing a key, its clone replaces it, just like with the weapons. In Deathmatch play, however, every player enters the game already holding any and all keys for the level. This means that everyone will have access to the entire installation.

THE STATUS BAR

The only difference in the Status Bar is that in Deathmatch the ARMS section is replaced by "FRAG." A frag is a kill of one of your human opponents. During Deathmatch play, you will see a running count of your frag numbers. (Remember, you can kill your opponents more than once.)

THE AUTOMAP

During Cooperative play, the Automap will show you locations for all players. Each player will be pictured as a colored arrow corresponding to the color of the player's uniform. In Deathmatch play, you will not be able to see other players.

SPY MODE

During Cooperative play, you can press F12 to access other players' views. To return to your own view, press any other alphanumeric key. While switching to someone else's view, your Status Bar will continue to reflect your own conditions. However, if your screen reddens, it is because *you* are being damaged—not the other player.

During Deathmatch, you will not be able to switch to anybody else's view.

GAME TALLIES

At the conclusion of a level, the tally will vary depending on the play mode. In Cooperative play the tally shows each player's achievements, just as during single-player mode. In Deathmatch play the tally summarizes each player's death count. This will tell you who got killed by whom and how many times.

BASIC GAME OPERATIONS

This section explains the new controls and options available during MultiPlayer mode. The new controls consist of the Chat and Spy features. The new options have to do with operations such as pausing, saving, or loading a game.

NEW CONTROLS

Chat

The Chat feature lets you broadcast general messages or address them to a specific player.

Broadcasting a Message To broadcast a message for everyone to read, press **t**. Then type the message.

Addressing Someone To direct a message to a specific player, press the first letter of the player's uniform color (**b** for brown, **i** for Indigo, **g** for green, and **r** for red). Then type your message.

Sending Prerecorded "Macro" Phrases When sending a message, you can type whatever you like or you can quickly choose one of ten built-in "macro" phrases. You can view or change these phrases in the Setup menu. To send any of the macro phrases, press the letter for the desired player, and then press Alt and the number that identifies the macro.

Spy

The Spy feature is only available during Cooperative play. When you engage it, Spy lets you see what another player sees. Press F12 to activate Spy. Press F12 repeatedly to cycle to other players' views. To leave the Spy mode and return to your own perspective, press any alphanumeric key.

While you are engaged in Spy mode, your Status Bar will still show your own conditions.

NEW OPTIONS

In MultiPlayer mode, basic operations like pausing, saving, and loading games operate differently than in single-player mode. This section explains the differences.

Pausing

If anyone presses Pause, the game stops for everyone. But any person can resume the game by pressing Pause, too.

Saving a Game

Anyone can save the current game without stopping the action for the others. When you or anyone saves a game, the game is saved for all players, since all have access to the same Save slots. (It might be a good idea to decide what slot to use with the others beforehand.)

Loading a Game

It is not possible to load a saved game while others are playing. Every person must first quit the game. Then everyone should start Doom from the saved game using the Setup menu.

MULTIPLAYER PLATFORMS

Doom can be played in MultiPlayer mode over a network or through a serial modem. Ideally, the network should follow Novell Netware's protocol, IPX. This type of network is very common in office environments. If your network is of a different type (Lantastic, Windows for Workgroups,

or other) you might have to load special drivers. Hank Leukart's "The Official Doom FAQ" does an excellent job of prescribing what to do for engaging MultiPlayer mode in these situations. Leukart's sheet, updated regularly, is available in various online platforms (CompuServe, the Internet, and Usenet). See Appendix C for exact addresses.

LAUNCHING MULTIPLAYER MODE

There are two ways to launch Doom in MultiPlayer mode, whether you are linked with others via a network or whether you are linked serially through a modem or a null modem. The first way involves the Setup menu. The second way is through command-line parameters. Refer to the appropriate section below to find out about each method.

THE SETUP MENU

The Setup menu, available when you run the Setup program, gives you several options for controlling different aspects of the game. Appendix C covers each Setup menu option in detail. This section focuses only on launching MultiPlayer mode.

- 1 Type **SETUP** at the Doom directory and press **.J**. After a few seconds, the Setup menu is displayed.
- 2 Select Run Network/Modem/Serial game. You will be prompted to select a network device.
- 3 Choose the type appropriate to your situation. The next prompt will vary depending on the device you selected.

Make a selection for each option. Then start the game by pressing F10.

To start MultiPlayer mode using the command line, you may use one of two special programs. The first program, **SERSETUP**, works for serially linked players. The other,

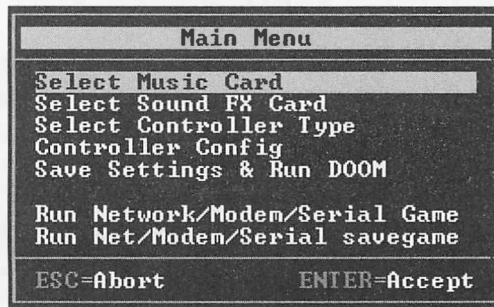

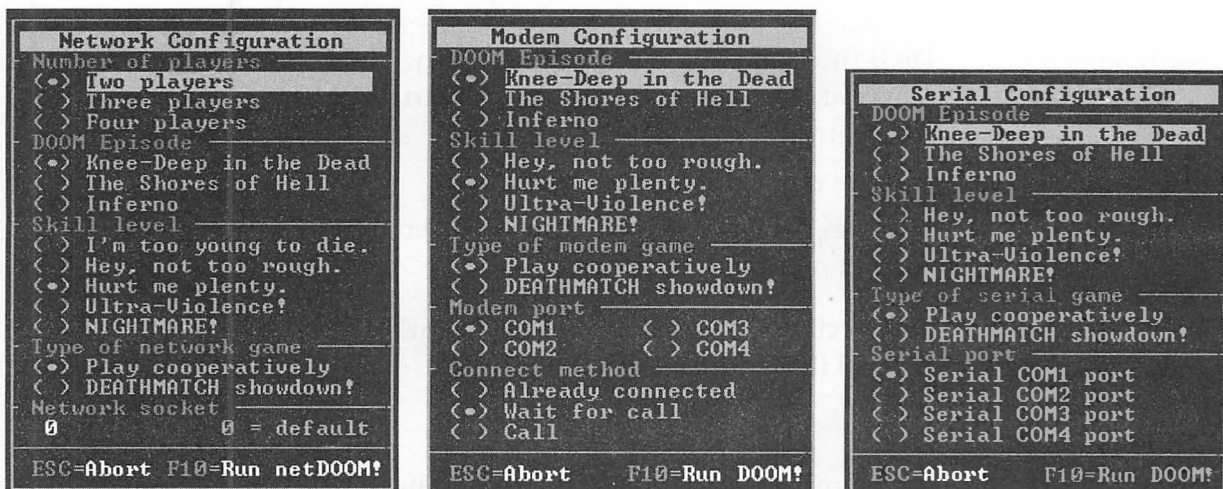

FIGURE 7.1 Network, Modem, and Serial-Link options

IPXSETUP, is for use by players on an IPX network. After issuing the appropriate command, you can include one or more additional *line parameters* to play Doom. Line parameters let you specify various options, such as playing cooperatively or in Deathmatch mode, setting skill levels, and so on. For example, the following line calls a person through a modem on COM2 and sets up Deathmatch with no monsters:

```
SERSETUP -dial 19165550343 -com2 -deathmatch -nomonsters
```

The following paragraphs detail the basic use of SERSETUP and IPXSETUP for initiating multiplayer. The complete listing of command-line parameters may be found in Appendix B.

SERSETUP

If you are linked serially, access the Doom directory and then issue the command **SERSETUP** and, on the same line, one or more of the appropriate line parameters. (Refer to Appendix B for a complete list of line parameters.)

The following are the basic commands you need for establishing a link and running Doom in MultiPlayer mode via a serial link:

- dial** *number* Dials the telephone number you specify. The player at the other end must use the **-answer** parameter.
- answer** Sets the modem to answer mode.
- com** *number* Specifies the COM port your modem/serial cable is on (a number from 1 to 5).

Note that if you do not specify either **-dial** or **-answer**, **SERSETUP** assumes you are making a serial link connection.

IPXSETUP

If you are connected to an IPX network, access the Doom directory and issue the command **IPXSETUP** and, on the same line, any line parameters you wish to include. (Refer to Appendix B for a complete list of line parameters.)

The only line parameter that applies exclusively to IPX networks is the following:

- nodes** *number* Specifies the number of players in the network (up to 4).

If you do not specify any parameters other than the command, Doom will start on the assumption that there are only two players.



**FOR THE
TECHNICALLY
INCLINED**

E I G H T

In this small but informative chapter, John Carmack takes you on a smooth cruise through the Doom game engine, giving you some behind-the-scenes looks at what it's really like to be involved in creating a super game program from the start.

GOALS

High Speed Doom is an interactive game, so it should be played at a rate of ten frames per second or faster. Our target audience is people with 386/33 and faster machines. With the selectable detail and screen size, slower computers can trade visual fidelity for more usable speed. At the high end, a fast Pentium machine can run Doom at 35 fps, its maximum speed, under most circumstances.

Freeform World Geometry All of our previous games had been "tile-based," which means the world was divided up into fixed-sized blocks that are chosen from a palette of pre-created data. The advantage of tile-based worlds is that you can create them quickly and easily, by repeating simple tiles many times. But making levels with many unique areas or with angled corridors can require thousands of small tiles of geometry. We wanted the ability to design levels without being constrained to a block-based world.

Infinite View Distance Most 3-D games follow the principle that only the objects within a certain distance are considered for drawing. This simplifies the rendering algorithms, but it forces the viewing horizon to either fade out rapidly (Ultima Underworld/Shadowcaster) or suffer the

disconcerting effect of having objects pop into view (most flight simulators and driving games) rather than appear as a distant speck and grow larger.

IMPLEMENTATION

The work of programming Doom can be divided into four roughly equal parts:

- Developing the rendering engine to draw pictures of the world environment.
- Developing the utilities used to create data for the game.
- Developing the world model that governs the interaction of things in the game world.
- Tuning and modifying the code as new circumstances arise.

The main game code consists of just under 30,000 lines of C code. The DOS version has three functions in assembly language: horizontal texture map, vertical stretch, and read joystick. The sound code was developed by an outside contractor. A fundamental aspect of our development strategy is that we use NEXTSTEP systems for almost all programming work. The powerful, stable development environment has enabled us to do much richer work than if we had restricted ourselves to working under DOS.

The game is structured so that it can be run in a window under NEXTSTEP, where it can be easily debugged, or recompiled to run full-screen under DOS. The rendering engine was actually developed mostly on a black-and-white NeXTStation at my home. It was structured so that the graphics could be drawn in grayscale, eight-bit color, or twelve-bit color (native to color NeXTStations). The refresh can also be used at any resolution, not limited to the PC screen size. Imposing the discipline of developing portable code has led me to some insights about better game architectures.

I usually categorize game rendering engines on three axes: speed, capabilities, and image fidelity. Speed is the relation of view window size to frame rate. Capabilities covers limitations to the world model, like 90 degree walls only, sloping floors, variable lighting, view height variability, etc. Fidelity includes the accuracy of texture mapping, any “fudging” done to improve speed, and things like anti-aliasing.

Our game design starts by selecting a speed for the game on our target platform, then trying to get as many capabilities and as high fidelity as possible. Doom’s world geometry is limited to a two-dimensional arrangement of lines representing walls, and flat floors and ceiling of variable heights. Doom cannot draw sloping floors, overlapping walkways, or tilted walls. The viewpoint has four axes of freedom: forward/backwards, left/right, up/down, and clockwise/counterclockwise. These are significant limitations for, say, an architectural walk-through program, but they provided us with a great deal of freedom for our game design. We are still finding new ways to exploit these capabilities as work progresses on Doom II. I am proud of the fidelity of the Doom engine. The texture mapping is sub-pixel-accurate, and there are no compromises with distance.

Because of the geometric limitations imposed on Doom, the hidden-surface removal problem can be reduced to a two-dimensional problem dealing only with the walls. The floors and ceilings are filled in to the remaining spaces after the walls have been properly drawn. This is a lot quicker than an arbitrary three-dimensional rendering scheme. The central algorithm Doom uses for the hidden-surface removal is a two-dimensional binary space-partition tree traversal. After a map has been drawn, it is passed to a separate utility which groups lines into sectors and recursively partitions the entire map into convex areas. This is a time-consuming task, but doing the work ahead of time lets the game perform less work at run time. The downside of this is that the lines that make up the world cannot have their endpoints adjusted during play. That’s why there are no swinging doors in Doom.

Our map editor was used day-in, day-out for almost a year by our game designers, so the effort expended on making it productive to use was well spent. *DoomEd* is the NEXTSTEP application we created to build and modify worlds. It allows us to design the geometry of the world

from a top-down perspective, and select the graphics to map onto the walls, floors, and ceilings.

The game world model was developed to support networking from the start. Each object in the world is processed through the same routines, regardless of whether it is a bonus item, a monster, or a networked player. Some of the world utility routines, like the bullet target and trace call, were actually more involved than the 3-D rendering routines.

The tuning of the entire project is the most important phase for making an enjoyable game. Subtle elements like the timing of an animation, the pitch of a sound effect, or the motion of an exploding body all impact the impression a user gets from the game. Proper tuning takes a long time, and a lot of testing, but the details really count. We experienced an interesting synergy in Doom, where several of the game elements regarding movement, combat, and the environment managed to complement each other so well that the game turned out better than our original vision of it. The normal process of game design starts with a glorious vision that is slowly torn down to reality as the project progresses. While our original plan was greatly changed, and some features were lost, the final product exceeded our early expectations.

AFTERTHOUGHTS

Doom is the first project I have worked on that I have still been proud of at its completion. I was not happy with Wolfenstein by the time it was released, and I was disappointed with my implementation of the Shadow-caster engine. I see a few warts, but I am still pleased with my work on Doom. There are a few remaining bugs in the refresh code that are unlikely to get fixed. Sometimes you will see a one-pixel-wide column stretching from the top to the bottom of the screen. This is a result of drawing a line that has its two endpoints transformed to almost exactly the same polar angle. The fixed-point arithmetic that calculates the scale for the column sometimes overflows, and the column goes to the maximum possible scale of 64 times normal height. Cuts on the floor or ceiling that are nearly vertical will also sometimes show an error.

There is a roundoff error in the map partitioner that can cause a few-pixel-wide segment of a line to be drawn in the wrong order. This results in a narrow strip of the floor and ceiling texture being drawn past the line that should have stopped it. Some of the artwork was drawn wider than the real width of the game object, so it is possible to have a piece of a sprite be seen past a wall under certain circumstances. I could have made Doom about 15 percent faster by paying more attention to the low-level Intel architecture. We all learned a lot during the development of Doom, and there are many new things for us to bring on in the next project. Watch out!



**INTERVIEWS
WITH THE DOOM
CREATORS**

N I N E

Doom is currently the centerpiece of id Software's jeweled crown. No stranger to praise and recognition, id Software has swept awards in previous years for its efforts with Wolfenstein 3D, Spear of Destiny, and Commander Keen. But Doom stands out for many reasons, not the least of which is that it is the closest thing to virtual reality in a PC game. The meticulous attention to lighting, texturing, and mapping render the Doom environment eerily believable. Doom's imposing architectural structures and its cast of interesting and fearsome monsters makes playing it a gaming experience unlike any other. In Doom, all technical aspects and creative efforts culminate in the flawless execution of a most alluring and entertaining action/adventure game.

The Doom creators are true pioneers in the game arena. One can only wonder what id Software will dream up next. In this section, you will meet some of id Software's bright talents and find out directly from them about the realm of Doom.

A BRIEF CONVERSATION WITH JOHN ROMERO AND SANDY PETERSEN, DOOM LEVEL DESIGNERS AND WRITERS

Writer's Note: I collected the following material while visiting id Software's "Dark Cube Tower" in the decidedly suburban town of Mesquite, just east of Dallas. It was a cold, rainy night. The Dallas skyline cut thin bright edges against the dark horizon of the north Texas sky. Heading east of town, I had to strain my eyes to see the dark, glass, cubic building that is home to id Software.

Upon arriving at id Software's headquarters, I got to put a face with John Romero's voice, a voice I had heard for the first time a couple of days before my arrival. Over the phone, John was open, friendly, enthusiastic, and eager to talk about Doom whenever the opportunity arose. In person, I encountered a young man of vibrant energy, long hair, and a classic conquistador beard. He was draped in a cape-like black leather coat that almost dragged the floor. It was easy to picture John as a sword-wielding knight in a fantasy/sci-fi novel or as a glam-metal rock star. The next morning, I had a chance to meet Sandy Petersen. Sandy's appearance was much more conventional than John's. Although he looked like he could be anybody's big brother, it was easy to see that Sandy's head was full of ideas as he spoke in torrents of words. A prolific writer in his own right, Sandy's manner was a mixture of cool control and fiery intensity. The three of us talked a while and I recorded our conversation. With some editorial license, I transcribed it here for you.

JM: *Tell me about the beginnings of Doom.*

Romero: Doom started out quite differently. At one point, the whole viewing perspective was from inside the Marine's helmet. Inside the helmet, there were all these little readouts that the Marine could consult at anytime—such as the Automap and health. But that was too confining and it also limited the viewing area. So the helmet got ditched in favor of the more unobtrusive status bar. At one point, too, the sky was black and the mountains were either blue or yellow. That made for rather drab outdoor areas. So we decided to give Phobos and Deimos semi-breathable atmospheres. We attributed their miraculous appearance to the power of the Anomalies. You still need a helmet to breathe well, but your view is in no way hampered by it. When you play in Deathmatch mode, you can see that the other players wear helmets and armors. But for all you know, you could be naked—there are no mirrors in Doom.

But going even farther back, at one point the Doom story line involved four characters, each of a different race and with different powers. The main character, was not the steroid-pumping Marine, but someone who had been thrown to the butt end of space because he sucked. That concept perished almost instantly because we wanted the player to feel

strong and capable. Incidentally, the main character now has no real personality. The less you know about him, the more likely you as the player will feel free to invent your own personality for him.

The level designs have also changed a great deal. Early on, the first level of the first episode looked much like an office with long corridors and connecting doors. We were going to completely thrash it or put it in some remote hard drive. You might be surprised that the level survived and underwent a dramatic transformation under Sandy Petersen's able hands. That level is now the Spawning Vats, the seventh level in *The Shores of Hell*.

JM: *What was the toughest aspect of creating Doom?*

Sandy: There were several tough parts. For programmer John Carmack, it had to be creating and optimizing the fastest 3-D engine anywhere. That is no trivial matter. For the artists, Kevin Cloud and Adrian Carmack, it had to be designing monsters without having seen the context of their surroundings. For me, it was exploring and implementing useful design possibilities using Carmack's engine. It was only near the end that we learned we could use the areas outside the buildings extensively. Also, we found out we could truly use the third dimension. In levels 1.7 and 3.6, you can climb and jump and actually move in the third dimension.

Another aspect of *Doom* that spurred some talk and debate was deciding how difficult or easy it should be. It's hard to tell. Some players are really hot: they never get hurt, they kill everything in sight, and they solve all the puzzles. Some are not so hot. But you must satisfy them all and be sure that each of them is having fun. It was late in the game that we implemented the "save game" ability. We knew it would make things easier. But we didn't know just how much easier. It makes tons of difference whether you start a level armed only with the lowly handgun or with a chaingun and buckets of bullets.

Romero [interjecting]: Except for *Nightmare*.

JM: *How do you compare your design styles?*

Sandy: This is a gross oversimplification, but in John Romero's levels there tend to be pulses of heavy action where tons of strategically placed monsters swarm over you. There are ways to kill them with exploding barrels and such. And after you are done, you pause for an instant and catch your breath before, behind the next door, you're ambushed once again. In my levels, there tends to be a steady stream of monsters. In level 3.6 for instance, you start out calmly, but as you move and begin opening doors and setting triggers, you start releasing monsters at almost every turn.

Romero: I think our differing designs actually enhance the game. It's not like you will be walking into a room and toasting all the monsters only to pause routinely and then move on to the next room and do the same thing.

[At this point, Sandy excuses himself, returns to his corner of the room and pops on some strange Bulgarian music for us all to enjoy. John Romero and I continue.]

JM: *What's in the future for id?*

Romero: More cool games. Quake, for instance. The technology of Quake will make Doom's 3-D engine seem dated. In Quake, there will be a polar-mapped sky. Everything will make you feel like you are in more of a real world. The textures will be at twice the resolution. Even though we'll still be using 320-by-200 screens, the difference will be in the screen size of a drawing. For example, a 64-by-64 block of texture in Doom will take up only a fourth of the screen space in Quake. This will make for much more intense textures and great realism.

JM: *What about the characters?*

Romero: The characters will be by far the biggest improvement. Instead of bitmaps, they will be 3-D computer models, based on actual physical models scanned as 3-D data. Once they're digitized, we will be able to assign articulation points, or *joints*, so the characters can move around in their 3-D environment. This will make for dramatic movement and an overall cinematic scope and feel to the game. Also, the immensity of the environment will dwarf you.

JM: *What is Quake's basic premise?*

Romero: Quake is subtitled "Fight for Justice." *Justice* is a benevolent organization with headquarters in "The Halls of Justice," where the characters can teleport to other dimensions. In many ways, Quake will be a medieval type of world, something akin to what you might think *Dungeons & Dragons* is all about. Although the plot isn't fully developed yet, there will be an evil character in the Justice organization. The game will also involve more psychological aspects and situations than Doom does. But there will still be plenty of Doomlike action.

JM: *Where do you get your ideas?*

Romero: For Doom, they came from *Aliens*, *Terminator*, *The Fly*, *Evil Dead*—and other cool cult B-movies. We also mixed our concept of Hell and made it clash with the space setting of Mars and its moons. For Quake, we used the D&D character with whom we'd been playing for years. While playing our brand of D&D, we were concerned with finding lines of power amidst great political struggles. So we retained this psychological aspect, not to mention the strange and magical facets of the game. Much of the game will also depend on how far we can take the AI [artificial intelligence] to incorporate many RPG [role-playing game] aspects with the action in Quake.

JM: *What sets id Software apart from other game companies?*

Romero: We are a small company and want to remain small. We will continue concentrating our efforts on one game at a time. With larger companies, you have development teams that basically compete with each other. It's like: everyone wants to be in So-and-so's group because So-and-so owns half the company. This situation takes away from a concerted effort to create the best game possible. At id, because we are small, everyone has to be able to do more than one thing. Most importantly, we must also share a vision and be like-minded.

JM: *What's going to happen with id Software into the millennium?*

Romero: We're going to be licensing our technology. We don't want to get huge. We'll stay small, make the coolest games, and continue relying on the shareware market to popularize our wares to the masses.

SANDY PETERSEN UNLEASHES THE LIZARD BRAIN: HOW I CREATED DOOM

Writer's note: This section was written by Sandy Petersen, Doom designer and writer.

Doom's levels were not designed by one single person. John Romero created all the levels in episode 1, Knee Deep in the Dead, from scratch, except for level 1.8. All the remaining levels were done by me, either alone or sometimes by converting someone else's earlier work into a more polished form. The following paragraphs give full credit for the remaining levels.

Though a great deal of changes were made to Tom Hall's and Shawn Green's levels (one a former id Software contributor, the other still with id Software), including placing monsters, repairing wall textures, and altering numberless small details, the basic architecture remains unchanged.

It is my belief that a perceptive player of Doom will sense a definite personality difference between the levels created by each of the designers. This effect may be slightly dimmed in the case of Tom Hall and Shawn Green, since their original distinctive style has been somewhat merged with my own through the heavy editing their levels underwent.

John Romero's particular lunacy appears to lie in flooding the player with seemingly unstoppable hordes of monsters, interspersed with long periods of tense quietude, as the player ponders what horrors are to be unleashed next. He often places monsters on distant vantage points, whence they can snipe at the player in relative safety. John's levels are riddled with special vantage points, cunning secret areas, and multilevel action.

John almost always starts out a level with a nightmarish bloodbath to get the player's adrenaline flowing. Only after you have survived this onslaught can you take a break and decide where to go next. Another tendency of John's is to make the level linear. If you don't count the many secret passages, you pretty much have to go through John's levels in the order he prescribes.

On my own levels, I tend to present the player with a constant trickle of monsters, unlike John's episodic bursts of terror. Also, instead of John's diabolic secret tunnels and platforms, I tend to assault the player with booby traps and snares. The classic example is the "false exit" on E2M6. It looks like an exit, it smells like an exit, but it's not really an exit.

My levels start out kind of quiet, with the player left on his or her own. There's usually a monster or two right around the corner, but not the slaving horde you may have learned to expect from John. Some of my levels are quite linear (E3M1 or E3M4, for instance), but others, such as E3M2, E2M5, and E3M6 leave the area wide open for players to explore almost anywhere they want. I've found that some players really like this type of free-form experience, while others feel lost and confused until they manage to figure out the "right" way to go (which generally varies from player to player).

Three things must be kept in mind at all times while designing levels for the players:

- 1** How does it look?
- 2** Is it fun?
- 3** Did you remember to clean up?

How Does It Look?

This was the hardest part of level design to learn, at least for me. It seemed to come naturally to Romero, while I had to work and work. The basic problem is that in order to design a good-looking room for Doom, you must think architecturally. That is, you must see the room in terms of spaces rather than as a set of lines on a map. The exact wall textures used to give animation and color to a room often are secondary to the room's actual structural components. Some rooms end up looking very good indeed, while others are not as impressive, despite colors and structures.

For instance, we've never been really happy with the large entry hall on E1M4. It does the job and is fun to play in, but it just doesn't seem to have that zip. An open hole in the roof and numerous alterations in the chamber's decor didn't wholly fix it. In the end, we decided that it played just fine, so we'd leave it and move on to other things.

In the early design of Doom, there was a tendency to have lots of twisty little mazes. As playtest began, we discovered that these usually weren't too much fun, and most of them have been discarded (with a few exceptions, mostly in Tom Hall's old levels). Even the ones that remain have been altered and simplified in most cases, or serve a purpose by being claustrophobic and frightening (for instance, check out the excellent final maze in E1M4, the "upstairs" maze in E3M3, or the lava maze in E3M7).

Is It Fun?

This is, of course, even more important than making the game look good—if it doesn't PLAY well, it just doesn't matter how good it looks. Making a level fun, for me, was a combination of an initial overall plan and continual playtest.

When I began a level, I thought long and hard about the overall theme of that level—what the player was supposed to get from it. For example, on E3M5, I wanted to give the player an illusion of a vast fane or temple, with a symmetric and understandable architecture. At first, players on this level are puzzled, with the teleporters, released monsters, and so forth, but soon they understand the level's overall structure and are racing round it with ease. Once players comprehend the layout, they are able to approach E3M5 scientifically and rationally, which gives them an interesting contrast (I believe) between the emotionally laden nature of that level (a huge cathedral) and their own behavior.

On the other hand, on E3M1, the goal was simply to overawe the player with the wonders that await them in Hell. The level teems with ominous and frightening images from the start, where you find yourself outside under a glowering red sky, chased by Imps. When you open the promising door to escape, it releases a Cacodemon. The bridge leading to the shotgun collapses, etc. You're kept running around, seeing ever more

ominous and weird sights and terrors that quickly teach you the different nature of Hell, as compared with the more rationally constructed levels of episodes 1 and 2.

Once I've got my theme worked out, I'll generally complete one small area of a level, then quickly playtest it. If it seems to work and looks fine, I'll complete the next area, and test both completed areas out together, continuing to do this until the entire level is finished.

Did You Remember to Clean Up?

Just because a level looks good and plays well doesn't mean it's done. Now I've got to make sure I've thought of everything. Is there enough ammunition and weapons for the players? How about bonus items? Players expect them, and they're easy to leave out. Did you remember to mark secret areas? And are there enough traps and tricks to keep the players amused?

After trying to cover these pathetic tiny details, I have to probe deeper. Is there some way that a clever player can bypass all the action of the whole level? If so, is that okay? (Sometimes it is—if you're smart you can skip almost the whole of E3M6, and I don't mind a bit; but you'll miss out on a lot of weapons and interesting combat.) How does the level mesh with the one preceding? The one following? If the start room of level B includes a single lonely Cacodemon coming at you down a long hall, but you were given the opportunity to pick up a rocket launcher in the exit room of level A, you aren't presented with much of a problem. On the other hand, if that rocket launcher is at the very *start* of level A, so that you only have it available in level B if you carefully held onto your rockets, this might be okay—you should be rewarded for your stinginess.

When the final level is done, I play it a few more times, looking for flaws and mistakes (I find plenty of these), then I turn it over to those rotten excuses for human beings, the other id-iots at id Software. They quickly find all sorts of terrible things wrong with my poor baby level, and I fix these as rapidly as possible to avoid the rancorous comments and snide laughter that results when they expose flaws I've built into an area. If I sound like a bitter man, there are reasons.

KEVIN CLOUD ON THE ART PROCESS OF DOOM

Writer's note: This section was provided by Kevin Cloud, id Software artist and writer.

In games, good computer art is commonly referred to as “beautifully rendered or detailed” because most good game art looks meticulously hand drawn. Unfortunately, beautifully rendered worlds often begin to look staged. For Doom, we wanted to create a realistic and dark world that looked more dirty than pretty. There was nothing beautiful about Doom and we wanted its world to convey that concept—scary and dark.

To achieve the intended effect we used a combination of scanned and hand rendered images. John Carmack created the program, Fuzzy Pumper Palette Shop, that would capture live video images and convert them into a PC graphic format. We then loaded the images directly into our PC art applications where we could edit, resize, colorize, and combine them—whatever it took to create an interesting graphic. The overall effect is somewhat distorted, but that's Doom.

The characters in Doom were created using a variety of methods—hand drawn, scanned clay models, and finally, latex and metal models. After working on Wolfenstein, we knew the frustration of creating the rotated views of every animation of a creature. Most characters are easy to draw from the front, but rotate them 45 degrees and things become a little more complex. Using small wooden mannequins and a couple of pounds of clay, we set out to make our own models. This technique wasn't perfect, but it enabled us to pose the creatures in stances we would normally not draw.

As the project neared its end, we wanted to create a monster that wasn't a biped. We came up with the idea of a large brainy creature with a chaingun embedded into its face, and its body attached by several large metal hooks to a four-legged metal machine. We couldn't create this guy using clay, and that's when we contacted Gregor Punchatz.

Gregor has an extensive background in creating models. Working on the sets of such movie classics as *Nightmare on Elm Street* and *RoboCop*, Greg had the tools and the talent necessary for creating models. Within a

few weeks, Gregor had turned our sketches into a fully moveable monster. The process worked well. And although this version of Doom only features one of his creations, the retail version of Doom will fully utilize Gregor's talents.

HAPPY DOOMING

There is obviously a lot more to Doom than what you see on the screen, and there is much more the Doom creators could have shared with us. I hope the above discussions have at least given you an insight into the minds of the Doom creators and an appreciation for the art and science of Doom. For more technical information about playing and enjoying Doom, look for your specific topics in the appendixes.

APPENDIXES



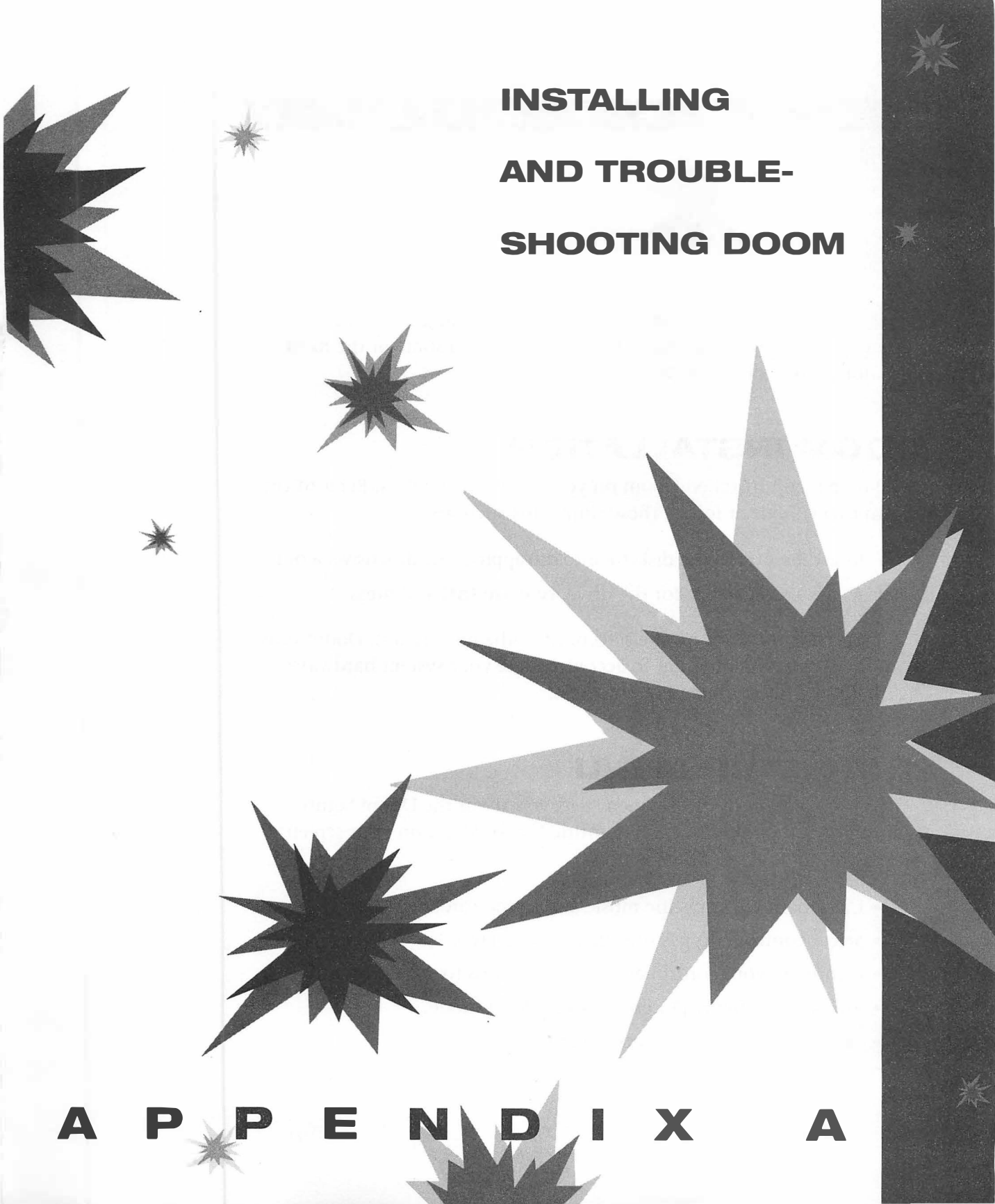

**INSTALLING
AND TROUBLE-
SHOOTING DOOM**

A P P E N D I X A

This appendix goes over the procedure for installing Doom on your system. It also covers the Main Menu and gives you some of the most common troubleshooting tips.

DOOM INSTALLATION

If you haven't installed Doom on your system, do it now. Refer to the Doom *User's Guide* or follow these simple instructions:

- 1** Insert the first Doom diskette into the appropriate disk drive, a or b.
- 2** At the DOS prompt for the drive, type **install** and press ↵.

Follow the directions on the screen. After the installation, Doom runs a short customizing program to accommodate your system hardware. Again, follow the on-screen instructions.

THE SETUP MENU

The information in this segment tells you about the Doom Setup menu. The Setup menu (which is entitled Main Menu on your screen) allows you to do the following:

- Use Doom with specific music and sound cards.
- Select controller types (joystick, mouse, etc.).
- Configure your controller (assign functions to mouse buttons).
- Run and configure Doom for MultiPlayer mode.
- Run saved MultiPlayer-mode games.

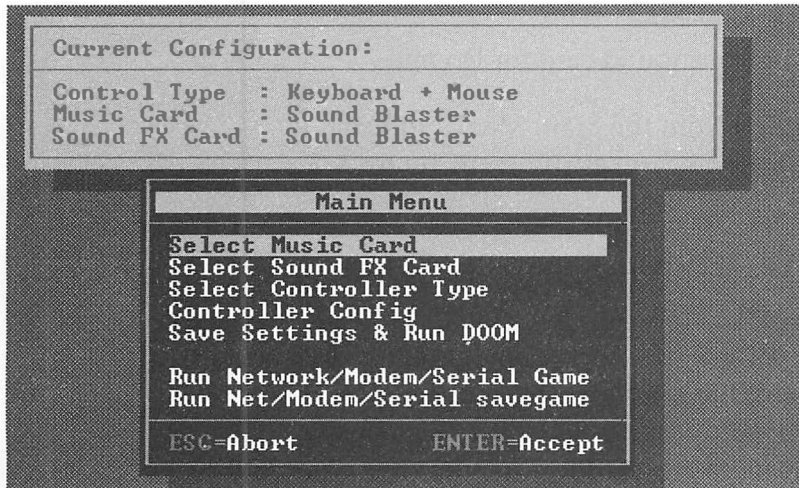

To access the Setup menu, go to the Doom directory and type **SETUP** at the DOS prompt.

Refer to the section below for working with any of the Setup options.

CHOOSING A MUSIC CARD

To choose the appropriate music card for your system, follow these steps:

- 1 Choose **Select Music Card** from the Main Menu (by highlighting it with the cursor keys and pressing \downarrow).
- 2 From the screen displayed (Figure A.1), select the type of music card you have installed on your machine and press \downarrow .
- 3 Now you are prompted to select the card's port. Choose the appropriate port for your card. (If you are unsure, refer to the card's documentation.) Then press \downarrow .

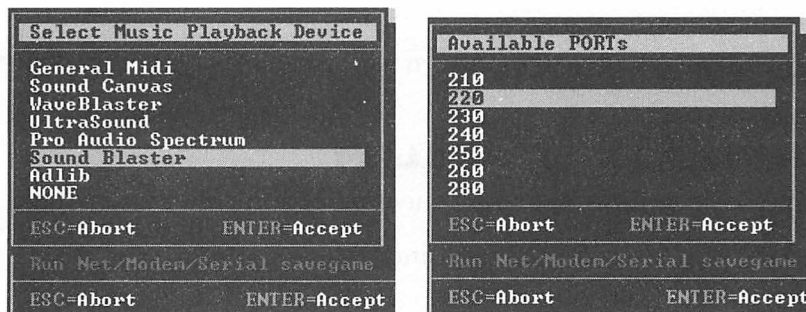

FIGURE A.1 Music card and port selection screens

The Main Menu then returns so you can make other selections.

CHOOSING A SOUND CARD

Follow this procedure to configure your sound card for Doom.

- 1 Choose **Select Sound FX Card** from the Main Menu. You are prompted to choose a type of sound card, as shown in Figure A.2.
- 2 Select your sound FX card and press ↵.
- 3 Now you are prompted for the card's port. Choose the appropriate port for your card. (If you are unsure, refer to the card's documentation.) Then press ↵.
- 4 Now you must specify the card's IRQ. Choose the appropriate IRQ and press ↵. (If you are unsure about your card's IRQ, consult the documentation that came with the card.)

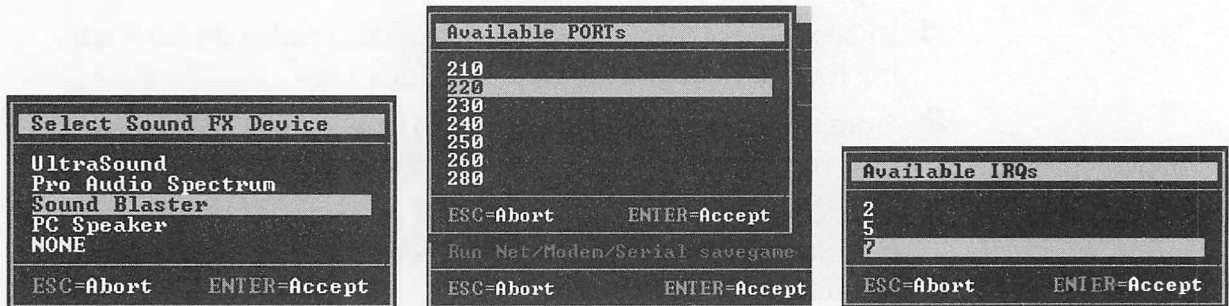

FIGURE A.2 Sound FX card selection screen, port selection screen, and IRQ selection screen

The Main Menu then returns to the screen so you can make other selections.

SELECTING A CONTROLLER

Use this simple procedure to choose the type of controller you will be using with Doom.

- 1** Choose **Select Controller Type** from the Main Menu. You are prompted to select the controller type.
- 2** Choose the controller you want and press ↵.

The Main Menu returns to the screen so you can make other selections.

CONFIGURING YOUR CONTROLLER

If you wish to change the setup of the fire, sidestep, and walk buttons on your mouse, keyboard, or joystick, follow this procedure:

- 1** Choose **Controller Config** at the Main Menu. You are prompted to choose the controller type for which you want to change the configuration.
- 2** Choose the controller type and press ↵.

Depending on your selection, you will get a special screen showing the current control assignment for your device, as shown in Figure A.3. Each of these screens leads you through similar steps. First you position the cursor over the function you wish to change, and press ↵. You will be prompted to type a new key or press a new button for that function. The new key or button will appear in place of the key you replaced. Press F10 to accept your changes and return to the Main Menu.

SAVING YOUR SETTINGS AND RUNNING DOOM

After you have configured the system for your cards and controllers, choose **Save Settings & Run Doom** from the Main Menu. The Setup program will terminate and Doom will start automatically.

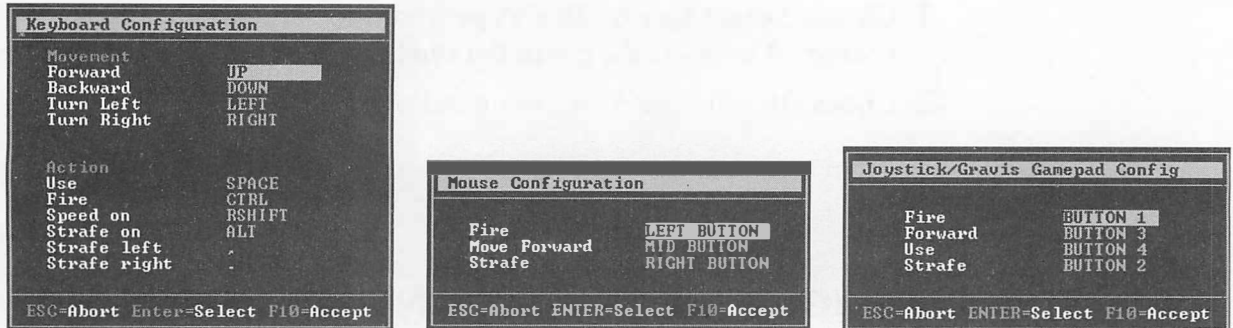

FIGURE A.3 Keyboard, mouse, and joystick configuration screens

RUNNING AND CONFIGURING DOOM FOR MULTIPLAYER MODE

Doom can be played in MultiPlayer mode over an IPX network or through a serial modem. If your network is not IPX (for example, if it is Lantastic or Windows for Workgroups) you might have to load special drivers. Hank Leukart's "The Official Doom FAQ" is the best source at this time for instructions on engaging MultiPlayer mode in these special situations. Leukart's sheet is updated regularly and is available in the Games library of the SYBEX forum on CompuServe (and various other online platforms). The following instructions are for starting MultiPlayer mode over an IPX network or via serial modem.

- 1** Select **Run Network/Modem/Serial Game** from the Main Menu.
- 2** You will be prompted to choose the type of selection appropriate to your situation. The box you see next will vary depending on the device you selected. The possibilities are shown in Figure A.4.
- 3** Make a selection in each option group from the appropriate screen. Then start the game by pressing F10.

RUNNING SAVED MULTIPLAYER-MODE GAMES

If you wish to resume a MultiPlayer game that you saved earlier, follow these steps.

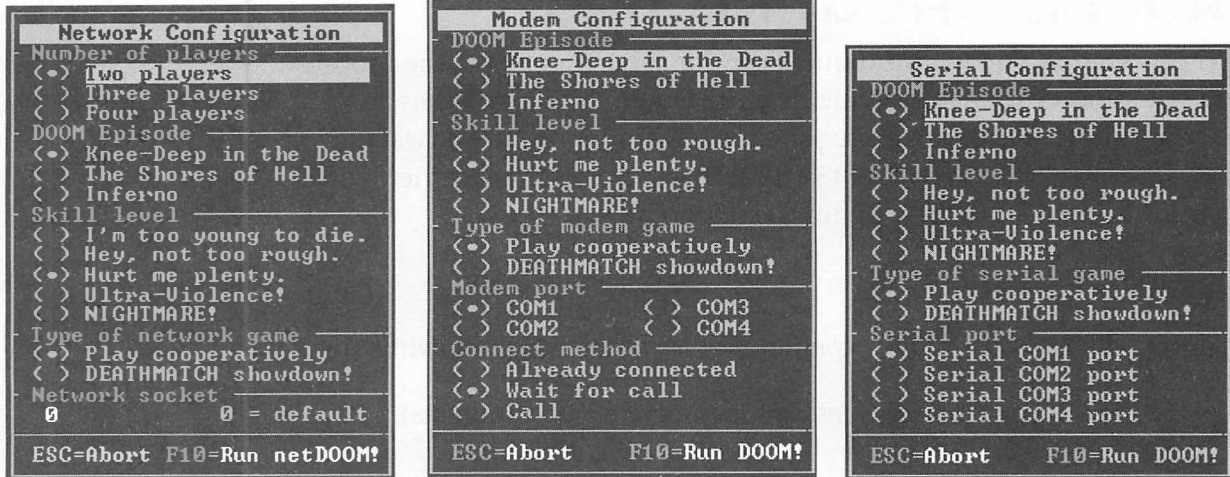

FIGURE A.4 IPX network, modem, and serial-link options screens

- 1 Select **Run Net/Modem/Serial savegame** from the Main Menu and press ↵.
- 2 Choose the type of network device you want and press ↵. The next screen, to resume a saved network game, depends on the option you choose here. The possibilities are shown in Figure A.5.
- 3 Make the desired selection in each option group from the appropriate screen. Then press F10 to start the game.

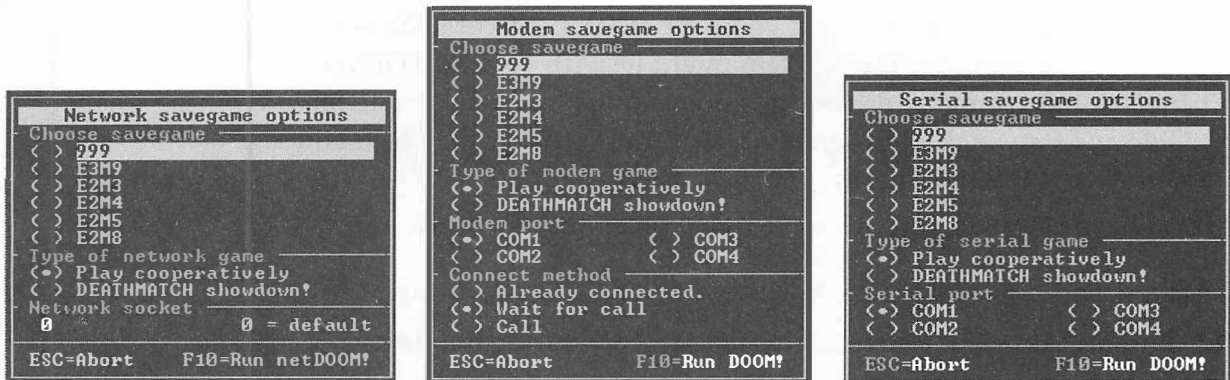

FIGURE A.5 Option screens for selecting network, modem, and serial-link saved games to restart

TROUBLESHOOTING TIPS

In this section you will find quick tips for solving many of the problems you might experience while running Doom. Most problems are easily solved. However, if you require technical support, id Software maintains open lines at (214) 613-0132. If you are on the Internet, you can also reach id Software's technical support at:

help@idsoftware.com

Most problems you might experience will occur in the following areas:

- General Operation (crashes and memory-related problems)
- Sound
- Control
- MultiPlayer (network and modem)

Read the question/answer sections ahead for useful advice in each of these areas.

GENERAL OPERATION

Q: *Why do I keep getting the "Out of Memory" message?*

A: This occurs for some users of version 1.1, Doom must have at least 4Mb of RAM. If you have any less than that, you will continue to see the *Out of Memory* message. However, if you have at least 4Mb of RAM but still get the same message, the problem might lie with your AUTOEXEC.BAT file loading too many drivers. It is not unusual to have several TSR (*terminate-and-stay-resident*) programs in that file. Each one may be taking up memory that Doom requires.

If you have DOS 6.0, you can solve this problem in one of two ways:

- 1** Press and hold the Shift key while your machine is booting.
- 2** Run MEMMAKER to free additional memory during booting.

If you are using DOS 5.0 or earlier, consider renaming your AUTO-EXEC.BAT file to something else (like AUTO.BAT) and then rebooting so that nothing is automatically loaded into memory at startup. Just remember to rename the file *back* to AUTOEXEC.BAT after you've finished playing Doom.

A fourth way to solve the problem is to run Doom without using HIMEM, EMM386, or any other memory managers.

Q: *Why does my system crash when I start Doom?*

A: This occurs for some users of version 1.1. System crashes on a consistent basis might mean that your motherboard does not respond to the DOS extenders used by Doom. Rather than replacing your motherboard, you can simply use the adequate DOS extender. If you have access to the Internet, you can download a file called ALTDOOM.ZIP. (See the last half of Appendix C for some of the FTP sites on the Internet.) If you do not have access to the Internet, you can get the file from the official id Software BBS, Software Creations. Here are the numbers:

(508) 365-2359	2400 baud
(508) 368-7036	9600-14.4K v.32bis
(508) 368-4137	14.4-16.8K HST/DS

Q: *The patch for version 1.2 fails to install correctly. What's wrong?*

A: The version 1.2 patch modifies some files in your Doom directory. So if you have renamed the directory or have altered the DOOM.EXE file with a new version, you might experience problems installing the patch. Also, there were two 1.1 versions of Doom. The older of these will give you problems with the patch. If you are a shareware user, you can avoid any problems by downloading the most recent shareware version and then applying the patch. It is also possible that you might have an older registered version. Call your distributor or e-mail id Software for help (help@idsoftware.com).

Q: *How can I get Doom to work with SMARTDRV.EXE?*

A: This problem might be circumvented by adding the following line to your CONFIG.SYS file:

```
DEVICE=C:\DOS\SMARTDRV.EXE DOUBLE_BUFFER
```

SOUND PROBLEMS

Q: *Why don't I get any sound?*

A: The most obvious cause for this problem is that Doom is not configured for your sound card. Run the SETUP program to check that Doom is using the correct setting. Be sure to save your settings before leaving the SETUP program.

Q: *I have a Sound Blaster-compatible sound card, but I still don't get any sound. What can I do?*

A: Your compatible card probably needs to be run in the Sound Blaster emulation mode. This might be accomplished through a software command or a card switch setting. Refer to your card's documentation.

Q: *I have a Gravis UltraSound card. Can it work with Doom?*

A: Yes. But for it to run properly, you must perform four steps:

1 Set the ULTRASND environment variable, as in

```
SET ULTRASND=220,1,1,7,5
```

2 Install the "General MIDI patch" that came with your Gravis card.

3 Place the following line in your AUTOEXEC.BAT file:

```
SET ULTRADIR=C:\ULTRSND
```

4 Copy the ULTRAMID.INI file into your Doom directory and rename it DMXGUS.INI.

Q: *Why can't I get my ATI Stereo-F/X sound card to work with Doom?*

A: Turn off DMA buffering in the sound card's SFX.EXE configuration program.

CONTROL

Q: *Why does my mouse move by itself during play?*

A: You might be using an older mouse driver. If you are using a Microsoft mouse, use drivers 9.x instead of 8.x.

Q: *I have a two-button mouse. How can I get it to work with Doom?*

A: Doom assumes that you are using a three-button mouse. The default assignments for the buttons are primary button, fire; middle button, sidestep; and right button, forward. With a two-button mouse, you must edit the file DEFAULT.CFG in the DOOMDATA directory using an ASCII text editor. Look for the line

```
mouseb_fire -1
```

and assign it a value of **1** (as in mouseb_fire 1). The values for the other mouse control lines are

```
mouseb_fire 0
```

and

```
mouseb_strafe 2
```

With this setup you can fire with the primary button and sidestep with the right button.

MULTIPLAYER MODE PROBLEMS

Q: *Why does network play slow down?*

A: You might be running an older Doom version (1.0 or 1.1), which uses broadcast packets. Version 1.2 uses directed packets, which are significantly faster.

Q: *Why doesn't my modem work with Doom?*

A: You might be using a nonstandard IRQ for your COM port. There is a shareware utility that changes default IRQs so they are suitable for

Doom. In addition, Doom may require that you use a special initialization string with your modem. Here are a few strings you might use for some common types of modems.

Boca M1440i (internal)	AST48=0S37=9S46=136%C0%E0%M)&K0 &Q0&R1&C1&D2\G0\N1N0
Boca 14.4 Fax/Modem	AT S46=0 S37=9 N0 &Q0 &D2 &K4
Digicom Systems Scout Plus	ATZ*E0*N3*M0*S0*F0&D2
Gateway Telepath 14.4k	AT S46=0 S37=9 N0 & Q0 &D2 &K0 %C0
Generic 14.4k Fax/Modem	AT S46=0 S37=9 N0 &Q0 &D2 %C0 \G0 &K
Hayes 28.8k V.FAST Modem	AT &Q6 &K S37=9 N %C0 \N0
Intel 14.4k	AT \N0 %C0 \Q0 B80
Practical Peripherals 14400FX v.32bis	AT Z S46=0 &Q0 &D20
Supra	AT &F0 S46=136 %C00
Telepath 14.4k	AT &F&M0&K0&N6&H0 S0=10
USR Sportster 14.4k Fax/Modem	AT S0=1 S7=60 E1 Q0 V1 &C1 &D2 &K0 &N6 &A30
Zoom 14.4k VFX	AT&Q6S37=9N0%C\N0

For a more inclusive list, consult "The Official Doom FAQ" by Hank Leukart. This resource can be obtained from the Games library of the SY-BEX forum on CompuServe, the Action/Arcade library of the Gamers forum on CompuServe, or from various FTP sites on the Internet. (See the last half of Appendix C for some of the Internet locations.)



CHEATERS

ALWAYS FINISH

FIRST

A P P E N D I X B

There's a loophole to every law, a backdoor to every main entrance, and a crack to every safe. Who was it that said, "All's fair in love and war"? Don't search too hard for an answer. It's probably just the collective unconscious speaking to us all. Thank God id Software built cheat codes into Doom. Cheat codes can save the day, if not your sanity, when your level of frustration has reached its peak.

In this appendix, we'll let id Software designer John Romero explain the inside story on the cheat codes that can be used by those in the know.

CHEATING IN DOOM

While programming Doom, we needed our own set of cheat keys to be able to test various aspects of our game design. This helps speed game creation. By leaving cheat codes in the game after its release, others are able to enjoy the game even more. All the cheat codes are prefixed with *ID*, because, you know.

We created the **IDDQD** cheat mode so we could watch the attack frames of an attacker, so we didn't get killed while analyzing. Why DQD? Well, one of id's programmers, Dave Taylor, was part of a three-person group called Delta-Q-Delta. They named themselves DQD because they were the fraternity of guys who would Quit their college classes before getting F's.

When the Automap was being programmed, we needed to see if the special codes we put on the map line segments were correct, so we needed a cheat to display all a map's lines. This code is IDDT because Dave Taylor's signature is DDT with

NOTE

To use any of the cheat codes divulged in this appendix, you simply type the code as you are playing a game. (It is not necessary to press ↵ after typing a cheat code.) You can also use cheat codes when you have paused the action.

an arrow through it. In the Automap, type **IDDT** twice and you will see all the things that can be seen in a map and your player will be an arrow with DDT over it!

Some people wanted a simple cheat that would give them just the chainsaw. **IDCHOPPERS** is for those people. This was a post-v1.0 release cheat. Sometimes, for debugging purposes during gameplay, the programmers needed to get the coordinate of the player. Thus, the **IDMYPOS** cheat code came squealing into existence. To test all the powerups quickly without having to find them in a map, the **IDBEHOLD** cheat was needed. Type **IDBEHOLD**, then **I** for Invisibility, **S** for Berserk Pack, **V** for Invulnerability, **R** for radiation suit, **A** for computer area map or **L** for light amp goggles. To test the various weapons, we created **IDKFA**. The KFA stands for “Killer F***ing Arsenal” and bestows upon you *all* the weapons, and maximum ammo for all of them. Have fun.

For warping to all the maps in the game, we created the **IDCLEV** cheat. Type the code, then type **1**, **2**, or **3** for the episode number, then the map number (a number from 1 to 9). For example, to warp to E3M6, you would type, **IDCLEV36**.

While designing maps, sometimes (!) we made mistakes with switches and triggers and inadvertently closed ourselves off from the rest of the map, so we created the **IDSPISPOPD** cheat code so we could walk through all the walls and out of our dilemma. Why did we name it SPISPOPD? Well, this is a little story that goes back many months ago, when the USENET newsgroup comp.sys.ibm.pc.games.action was positively going nuts waiting for Doom’s release. Many of the people on the newsgroup were tired of talking about Doom for almost a year, so they invented something *even cooler* that they could talk about, namely, the fictitious game SPISPOPD, or, “Smashing Pumpkins Into Small Piles Of Putrid Debris.” They invented all kinds of awesome things this game would do (using chainsaws on pumpkins) and who would be publishing it (Ego Software). They even created a FAQ (frequently asked questions) for it! Then—someone actually wrote the game! It wasn’t anywhere near as ambitious as the spec, but it was fun and is actually on the Internet Top 100 games list. So, we included its name as an inside joke to all the Doom players on the Internet.

COMMAND-LINE PARAMETERS

When you start Doom from the command line, there are a number of useful line parameters you can include to tailor the game to your specifications. All you have to do is access the Doom directory and then type **DOOM** as usual, except you can follow it (on the same line) with any number of the following parameters as appropriate. (You can also use any of these line parameters with the IPXSETUP or the SERSETUP programs for MultiPlayer mode, as discussed in Chapter 7.)

- skill** *number* Sets the skill level from 1 (easiest) to 5 (Nightmare).
- episode** *number* Lets you start playing in the episode of your choosing (1, 2, or 3).
- fast** Makes the monsters attack as fast as they do in the Nightmare level of difficulty.
- respawn** Makes the monsters come back to life after eight seconds (as in Nightmare).
- nomonsters** Starts Doom without any monsters (suitable for Deathmatch).
- loadgame**
number Loads a saved game identified by its slot number.
- config** *filename* Lets you load a configuration file other than DEFAULT.CFG, the one included with Doom.
- file** *filename* Adds the file of your specification to the list of files that are normally loaded when you run Doom. This parameter is typically used to override the graphics or maps residing in the DOOM.WAD file. (For example, if you have just downloaded a new E1M1 level from a CompuServe forum, you would add the parameter **-file newe1m1.wad**.)

"DEVELOPER" MODE

There's also a "developer" mode in Doom, invoked with the command **-devparm**. The various command-line parameters in developer mode allow level-warping, adding external .WAD files, recording screens ("screen shots"), and other miscellaneous stuff. Just make sure you have devparm on the command line, and then type any of these other parameters:

- | | |
|---------------------------------|---|
| -warp <i>x y</i> | Warp to episode <i>x</i> , level <i>y</i> . |
| -record <i>name</i> | Records your current game and saves it under the name you assign it. (Use -warp to start at the level you wish to record.) The demo recording ends when you die, quit, or exit the game. |
| -playdemo
<i>name</i> | Plays the demo you specify. |

While in developer mode, you will see some flickering dots at the bottom of the screen. These dots tell you how many frames per second (fps) the game is running at. One dot is 35fps, two is 24fps, three is 17fps, and four is 14fps.

Any time you are playing Doom and the developer mode is engaged, you can take a screen shot of the ongoing action by pressing F1. Screen shots are saved in the Doom directory as PCX files. Each screen shot you take is automatically named DOOM*xxx*.PCX, where *xxx* will be an ascending number beginning with 000. Screen shots can be displayed and manipulated with any paint program that supports the PCX format, such as the Paintbrush accessory in Microsoft Windows.



**DOOM ADD-ONS
AND RESOURCES**

A P P E N D I X C



A P P E N D I X C



There are many imaginative, intelligent, and interesting people not just playing Doom, but actually adding on to it and sharing their contributions with others. These contributions are generally termed *add-ons*. Add-ons run the gamut from cheating utilities to sound and level modifiers. With each passing day, the number of add-ons grows. Many are available through the various on-line information networks and services (CompuServe, America Online, the Internet, etc.).

For your convenience, SYBEX has included many of the best Doom add-ons in the Games library of their CompuServe forum. If you have a CompuServe account, all you have to do is log in and issue the **GO SYBEX** command. Once in the SYBEX forum, access the Games library and peruse the list of Doom files containing the add-ons you wish to grab.

You can also type **GO GAMERS** in CompuServe and check out the profusion of files and messages in their Action/Arcade library. There are many many files here for many many games, not just for Doom.

If you're using Delphi or America Online or one of the other services that offers some degree of Internet connectivity, check out the USENET newsgroup ALT.GAMES.DOOM. Or see if you can find a local bulletin board service (BBS) that offers USENET groups and see if you can get it to make ALT.GAMES.DOOM available. ALT.GAMES.DOOM is a great forum for asking questions and finding tips, strategies, and add-ons. (Note, however, that ALT newsgroups on USENET come and go with some frequency.)

Finally, if you're not connected through a national service and none of the bulletin boards in your area offer USENET access, see if there are any bulletin boards in your area devoted specifically to games. If there aren't any

NOTE

id Software and SYBEX Inc. do not guarantee the operation or the applicability of these add-on utilities. Also, remember, many add-ons work only with *registered* versions of Doom.

Doom players on these boards yet, it's just a matter of time. Leave a message expressing your interest, and check back from day to day.

This appendix gives you a small sample of the types of Doom add-ons you can find for your gaming pleasure. Besides the brief survey, this appendix also lists some key locations for finding many more Doom add-ons.

DOOM ADD-ONS

Here is a listing of existing Doom add-ons that you will find in the SYBEX Games library:

DOOMEZ v1.2

This "in-line" editor lets you play any Doom episode and equips you with special weapons, ammunition, and other powers. DOOMFIX, another in-line editor, lets you manipulate many file-save parameters for single-player and modem-player modes. You can use the editor with the included batch file for warping to missions and arm yourself to the teeth.

Author: Wayne Sikes.

DOOM EDITOR, v1.0b.

This latest shareware version of Renegade Graphics' DOOM EDITOR, v1.0b, which lets you modify existing Doom levels, includes major improvements and tons of great new features. It supports all the architectural constructions, like crushing ceilings, teleporters, new doors, and more! Requires Windows 3.1. If you don't have the previous version, download RGDAUX.ZIP in this library to get CMDIALOG.VBX and COMMDLG.DLL. Also requires VBRUN300.DLL, available in Library 1 (General/Help) as VBRUN3.ZIP.

Uploaded by author Joe Pantuso (Renegade Graphics).

DOOM ARGH!

This is a new Doom level created with Renegade Graphics' DOOM EDITOR v1.0b, also available in this library. Requires registered Doom 1.2.

Uploaded by Joe Pantuso (Renegade Graphics).

DOOM LEVEL SELECTOR

This user-friendly interface lets you jump to any game level and allows you to choose any skill level. Comes complete with instructions in the file; just type **DOOMSL** to run. Operation is self-explanatory. Tested with Doom v1.2; may not work well with earlier versions. This upload corrects previous errors.

Uploaded by Bobby Osborne.

RanDOOM v1.41

RanDOOM v1.41 randomizes the placement of objects in the Doom playfield. It also has smarts: It won't let a pillar block the exit, or leave a key or card on the opposite side of the door. Nor will it prevent Deathmatch network play by erasing all the Deathmatch warp-in spots, or block completion of an episode by replacing the endgame bosses with other objects. In short, RanDOOM should always leave you with a playable level. Runs only with a registered version of Doom.

Uploaded by Patrick Joyce.

MODEM CONTACT LIST

This is a directory of Doom players who wish to participate in modem play. Contains entries from many states and several countries.

Compiled and uploaded by Jeff Forsyth.

DOOMSET.EXE v1.0

DOOMSET v1.0 is a saved-game editor for Doom v1.2. Its dialog-box Windows interface lets you change, add, or delete your percentage of health and armor. It also allows you to have the Computer Level Map and whatever ammo, weapons, and keys you want. Requires Windows 3.1. Freeware.

Uploaded by author, Ray Johnson (aka Gregory Smart).

MODEM HELP FILE v3.0

This is the Doom Modem Help File v3.0, a compilation of scores of modem INIT strings. It contains the information on modem options and connection methods.

Compiled and uploaded by Keith Turbyfill.

runDOOM v1.2

These files allow you to run Doom v1.2 over a network that uses Accton EN165x ISA Ethernet adapters.

Uploaded by Mark DeMazza.

DEU 5.0

The latest release of this object/thing editor (formerly NEWDEU 4.31). It allows you to add, delete, move, and change objects, or to edit various parts of the maps. Not a fully functional editor, but you can create some interesting things, modify .WAD files, or create PWADs. Works with shareware and registered versions of Doom v1.1 and v1.2, but only saves changes in registered versions. Supports a mouse. Source code included. Public domain software.

Written by Brendon Wyber and Raphael Quinet. Uploaded by David Saraniero.

E2M8 Playback

Demo playback file for use with Doom v1.2 that shows my favorite way to kill the Cyberdemon at E2M8. Recorded in Ultra-Violence mode.

Uploaded by Jason Laumeister.

Playback of Levels 1-4

Levels 1 through 4 recorded as Doom v1.2 demos ready for playback. These .LMP files are played in ultra-violence mode, demonstrating *all* the secret areas and achieving 100% kills. Includes batch file for playback. Requires Doom v1.2.

Uploaded by Carter Lee.

Doom Specs

"Unofficial Specs File," written by Matt Fell and released by Hank Leukart. Contains all known information regarding the structure of the DOOM.WAD file to assist you in creating add-ons for the registered version of Doom v1.2.

Written by Matt Fell. Released by Hank Leukart. Uploaded by FrostByghte.

DMAUD (Sound Editor)

Lets you store and extract sounds from DOOM.WAD files. Also plays sounds if you have a Sound Blaster card or compatible. Input files can be .AU, .VOC, .WAV, and .SND. Converts any sample rates as necessary.

Written by Bill Neisius.

Audio Editor

This is a Doom SFX player, SFX extractor, and SFX replacer. It stores sounds into, or extracts sounds from, DOOM1.WAD files (distributed with Doom shareware versions) and DOOM.WAD files (distributed with Doom registered versions). Also plays sound through Sound Blaster or compatible sound card. Used by SILLY.ZIP (in this library) for Silly Doom, and by DOOMCO.ZIP (in this library).

Written by Bill Neisius. Uploaded by Steve Simpson.

Doom Wallpaper

Doom Windows wallpaper, "Wish You Were Here." Montage of images from Doom. This is a .BMP conversion of DOOMAR.GIF in this forum. 640×480×256.

Uploaded by Neil Bonner.

Doom v1.2 Modem/Network Batch Files

These batch files simplify running Doom from the command line in network and serial direct-connect or modem games. Unzip into your DOOM directory, and type **HELP** and **MOREHELP** for information on how to use them.

Uploaded by Erik Carlseen.

Doom Modem Hints

This text file contains instructions for connecting a Doom modem game. Useful if you've tried just about everything and nothing seems to work.

Written and uploaded by Cris Williams.

Doom Stupid

Sounds from various locations and friends. Requires Doom Audio Editor, available in this library as DMAUD.ZIP.

Uploaded by author, Eric Wilkinson.

OTHER SOURCES OF ADD-ONS

There are many more Doom add-ons. Some of the more interesting ones can be obtained from id Software's bulletin board, Software Creations, or from certain Internet and Usenet locations. Here is a representative list of what you can find.

Doom Editor: The Real Thing v2.1 (doomed21.zip)

Gives you all the necessary controls to edit sounds, view bitmaps, change the look of walls and other surfaces, reposition or change objects, etc. Works only with Doom v1.1.

Created by Name Unknown, (pringler@cuug.ab.ca).

Available at FTP site wuarchive.wustl.edu/pub/MSDOS_UPLOADS/games/doomstuff.

Doom Sounds (doomsnds.zip)

A Windows program that will play the sounds from Doom. Requires a Windows sound card driver.

Created by Michael Albers (mal@netcom.com).

Available at FTP site wuarchive.wustl.edu/pub/MSDOS_UPLOADS/games/doomstuff.

Miscellaneous Sounds (dmmisc.zip)

Includes samples from Star Wars, Richard Nixon, PacMan, and Ren and Stimpy. Requires DMAUD (which can be found in this library).

Created by "Asthmahound."

Available at FTP site [ftp.uwp.edu /pub/msdos/games/id/homebrew/doom/pub/incoming/id](ftp://ftp.uwp.edu/pub/msdos/games/id/homebrew/doom/pub/incoming/id).

DMGRAPH v0.2 (dmgrap02.zip)

Stores graphics into or extracts graphics from the DOOM.WAD file in portable pixel format. (Graphics must have a resolution of 320x200 or less.)

Created by Bill Neisius (bill@solaria.hac.com).

Available at FTP site [wuarchive.wustl.edu/pub/MSDOS_UPLOADS/games/doomstuff](ftp://wuarchive.wustl.edu/pub/MSDOS_UPLOADS/games/doomstuff).

NEWDEU v4.1 (newdeu41.zip)

Lets you move things around and change floor and ceiling heights and textures. Also lets you modify light levels and change toxic sectors into normal areas.

Created by Raphael Quinet (quinet@montefiore.ulg.ac.be).

Available at FTP site [wuarchive.wustl.edu/pub/MSDOS_UPLOADS/games/doomstuff](ftp://wuarchive.wustl.edu/pub/MSDOS_UPLOADS/games/doomstuff).

Doom Utilities v0.1 (dmutil01.zip)

Lets you view maps and has zoom and pan effects. Provides multiple episode support.

Created by Bill Kirby (bkirby@netcom.com).

Available at FTP site [ftp.uwp.edu/pub/msdos/games/id/homebrew/doom/pub/incoming/id](ftp://ftp.uwp.edu/pub/msdos/games/id/homebrew/doom/pub/incoming/id).

FAREWELL, AND GOOD LUCK

If you get on line and wish to explore the ever changing realm of Doom, you will never be disappointed. There are many Doom-mongers out there armed with new ideas, shaping ever more fascinating Doom possibilities and landscapes.

id Software's official bulletin board, Software Creations, can be reached at the following numbers:

Modem Speed	Phone Number
2400 baud	(508) 365-2359
9600-14.4K v.32bis	(508) 368-7036
14.4K-16.8K HST/DS	(508) 368-4137

I N D E X

Note to the Reader: Throughout this index **boldfaced** page numbers indicate primary discussions of a topic. *Italicized* page numbers indicate illustrations.

A

add-ons, **280–286**
addressing players, 236
Albers, Michael, 285
ALT.GAMES.DOOM newsgroup,
280
Alt key, 7
ALTDoom.ZIP files, 269
ammunition, **30–31**
backpacks for, **35**
picking up, 12
status bar, 10, 10, 37
-answer parameter, 240
armor, **34–35**, 34. *See also* Com-
bat Armor vests; Security
Armor vests; Spiritual
Armor
cooperative mode, 44
importance, 55–56
status bar, 11, 38
arrow keys, 7
arsenal
ammo, **30–31**
cheat mode, 275
electronic gadgets, **32–33**
medical aids, **34**
protective items, **34–35**
supernatural artifacts, **36**
weapons, **28–31**
artifacts, **36**
cheat mode, 275
maps. *See* monsters, weapons,
and artifacts locator maps
assembly language functions, 243

Asthmahound, 286
ATI Stereo-F/X sound card prob-
lems, 270
audio. *See* sound
Audio Editor add-on, 284
auto-demo, 6, **16–17**
Auto-Spotting feature, **33**
AUTOEXEC.BAT files, 268–269
Automaps, **32**, 32
cheat modes, 274
MultiPlayer modes, 235
using, 42

B

backpacks, **35**, 35
Central Processing level, 97
Command Center level, 151
Computer Station level, 104
Containment Area level, 131,
133
Deimos Lab level, 143
Limbo level, 219
Military Base level, 117
Mount Erebus level, 211
Nuclear Plant level, 70
Pandemomium level, 190
Toxin Refinery level, 78
bait tactics, **44**
Barons of Hell, **25–26**, 25
Halls of the Damned level,
156–158
Pandemomium level, **188–189**

- Phobos Anomaly level,
 - 109–110
 - Spawning Vats level, **163–164**
- barrels, 11, **41**
- batch files, 284
- BBS (bulletin board systems),
 - 269, 280, 287
- Berserk Packs, **34, 34**
 - cheat mode, 275
 - Command Center level,
 - 151–152
 - Containment Area level, 131
 - Deimos Lab level, 143
 - Halls of the Damned level, 158
 - House of Pain level, 196
 - Mount Erebus level, 212
 - Slough of Despair level, 183
 - Spawning Vats level, 164
 - Unholy Cathedral level, 204
 - Warrens level, 229
- BFG 9000, **30, 30**
 - against Barons of Hell, 25
 - against Cyberdemons, 26
 - House of Pain level, **193–195**,
 - 197
 - Pandemonium level, **188–189**
 - against Spider Mastermind, 27
 - Unholy Cathedral level,
 - 202–203**
- bitmaps, viewing, 285
- blue flasks, 11
- blueprint and ideal route maps,
 - 50–51, 50**
 - Central Processing level, 91
 - Command Center level, 146
 - Command Control level, 80
 - Computer Station level, 99
 - Containment Area level, 128
 - Deimos Anomaly level, 122
 - Deimos Lab level, 138
 - Dis level, 222
 - Fortress of Mystery level, 171
 - Halls of the Damned level, 154
 - Hangar level, 61
 - Hell Keep level, 175
 - House of Pain level, 191
 - interpreting, **51–53**
 - Limbo level, 214
 - Military Base level, 113
 - Mount Erebus level, 206
 - Nuclear Plant level, 65
 - Pandemonium level, 186
 - Phobos Anomaly level, 107
 - Phobos Lab level, 86
 - Refinery level, 134
 - Slough of Despair level, 180
 - Spawning Vats level, 161
 - Tower of Babel level, 167
 - Toxin Refinery level, 72
 - Unholy Cathedral level, 199
 - Warrens level, 225
- Blur artifacts, **36, 36**
 - Central Processing level, 97–98
 - Computer Station level, 105
 - Deimos Lab level, 142
 - Halls of the Damned level, 159
 - Phobos Anomaly level, 111
 - Phobos Lab level, 90
 - Refinery level, 136–137
 - Spawning Vats level, 165
 - Toxin Refinery level, 79
 - Unholy Cathedral level, 204
 - Warrens level, 229
- Bonner, Neil, 284
- broadcast packets, 271
- broadcasting messages, 236
- bugs, **245–246**
- bulk cells, 31, 31

bullet clips, **31**, 31
bulletin board systems (BBS),
269, 280, 287
buttons, mouse, default settings,
8, 265, 266

C

C code, 243
Cacodemons, **25**, 25
 Deimos Anomaly level, 124
 Mount Erebus level, **208–209**
Carlseen, Erik, 284
Carmack, Adrian, 250
Carmack, John, 257
 programming by, 250
 technical discussion, **242–246**
cases, shell and rocket, 31, 31
cells, **31**, 31
Central Processing level, 90–91
 list, 92–93
 maps, 91–92
 secrets, **96–98**
 step by step, **94–96**
 strategy, **93**
chainguns, **29**, 29
 against Cacodemons, 25
 against Specters, 24
chainsaws, **29**, 29
 cheat mode, 275
 against Demons, 24
Chat feature, 44, 236
cheating, **274–275**
clips, **31**, 31
Cloud, Kevin, 250, **257–258**
color
 MultiPlayer mode, 234, 236
 secret doors, 13
-com parameter, 240
Combat Armor vests, **34–35**, 34
 Command Center level, 153
 Command Control level, 84
 Computer Station level, 105
 Containment Area level, 133
 Deimos Anomaly level, 126
 Deimos Lab level, 144
 Hangar level, 64
 House of Pain level, 196, 198
 Limbo level, 219
 Mount Erebus level, 211
 Pandemonium level, 189–190
 Phobos Lab level, 89
 status bar, 38
 Toxin Refinery level, 79
Command Center level, 145
 list, 146
 maps, 146–147
 secrets, **151–153**
 step by step, **148–151**
 strategy, **147–148**
Command Control level, 79–80
 list, 80–81
 maps, 80–81
 secrets, **84–85**
 step by step, **82–84**
 strategy, **81–82**
command-line parameters,
 239–240, **276**
communication in MultiPlayer
 mode, 44, 234, 236
comp.sys.ibm.pc.games.action
 newsgroup, 275
CompuServe, 272, 280
computer maps, **32**
 cheat mode, 275
 Command Center level, 151
 Containment Area level, 133
 Deimos Anomaly level, 126

- Deimos Lab level, 141
 - Pandemonium level, 190
 - Phobos Anomaly level, 111
 - Phobos Lab level, 90
 - Slough of Despair level, 185
 - Computer Station level, 98–99
 - list, 100
 - maps, 99–100
 - secrets, **104–105**
 - step by step, 101–104
 - strategy, **101**
 - config parameter, 276
 - configuring controllers, **265**
 - Containment Area level, 126–127
 - list, 127
 - maps, 128–129
 - secrets, **131–133**
 - step by step, **130**
 - strategy, **127**
 - control problems, **271**
 - Controller Config option, 265
 - controllers, **264–265**
 - cooperative MultiPlayer mode
 - vs. Deathmatch, **234–236**
 - strategies, **43–44**
 - coordinates in cheat mode, 275
 - crashes, system, 269
 - creation of Doom, interview, **248–252**
 - crossfire strategies, 41
 - Ctrl key, 7, 11
 - cursor, 9, 17
 - Cyberdemons, **26, 26, 228**
- D**
- Deathmatch MultiPlayer mode
 - vs. cooperative, **234–236**
 - strategies, **44–46**
 - DEFAULT.CFG file, 271, 276
 - default settings, mouse, 8, 265, 266
 - Deimos Anomaly level, 121–122
 - list, 122
 - maps, 122–123
 - secrets, **125–126**
 - step by step, **124**
 - strategy, **123**
 - Deimos Lab level, 137
 - list, 137
 - maps, 138–139
 - secrets, **141–145**
 - step by step, **140–141**
 - strategy, **138–140**
 - DeMazza, Mark, 283
 - demo, 6, **16–17**
 - Demons, **23–24, 24**
 - Command Control level, 84
 - Halls of the Damned level, **156–158**
 - Phobos Anomaly level, 109
 - Spawning Vats level, **161–163**
 - DEU editor, 283
 - developer mode, **277**
 - dial parameter, 240
 - difficulty levels, 9–10, 10, **18–19**
 - digit markers, 33
 - directed packets, 271
 - directories, 6
 - Dis level, 221
 - maps, 222
 - strategy, **222–224**
 - DMAUD sound editor, 284
 - DMAUD.ZIP file, 285
 - DMGRAPH v0.2 add-on, 286
 - dmmisc.zip file, 286
 - dmutil01.zip file, 286
 - DOOM ARGH! add-on level, 281

DOOM directory, 6
DOOM EDITOR v.1.0b, 281
Doom Editor: The Real Thing
v2.1, 285
DOOM level selector add-on, 282
DOOM menu, 9, 9, **17-18**, 17
Doom Modem Help File v3.0
add-on, 283
DOOM.WAD files, 284
DOOM1.WAD files, 284
DOOMAR.GIF file, 284
DOOMDATA directory, 271
DoomEd editor, 244-245
doomed21.zip file, 285
DOOMEZ v1.2 editor, 281
DOOMFIX editor, 281
DOOMSET.EXE v1.0 add-on, 282
DOOMxxx.PCX files, 277
doors. *See also* secrets
mouse for, 8
security cards for, 55
as shields, **41**
drivers, 238

E

E2M8 Playback add-on, 283
editors
map, 244-245
sound, 284-285
electronic gadgets, **32-33**
End game option, 19
entry locations in MultiPlayer
modes, 235
enzyme potions, 11
-episode parameter, 276
Episode selection screen, 18, 18

episodes, **55-56**. *See also* Inferno
episode; Knee-Deep in the
Dead episode; Shores of
Hell episode
cheat mode, 275
line parameters, 276
maps, **50-53**
secret levels, **56**
selecting, 18, 276
Esc key, 17
exits, 55
exploring, strategies, **41-42**
eyes on status bar, 38

F

face on status bar, 38
-fast parameter, 276
Fell, Matt, 284
"Fight for Justice" game, 251-252
fighting strategies, **40-41**
-file parameter, 276
firing, 8, 265, 266
flasks, 11, **36**, 36
Follow mode, **32-33**
Former Human Sergeants, **23**, 23,
41
Former Humans, **22**, 22
Forsyth, Jeff, 282
Fortress of Mystery level, 170
maps, 171
step by step, **170**, **172**
frames per second, 277
freeform world geography, 242,
244
future games, **251-252**

G

gamma selections, 10
 gates, opening, 12
 gateways, 5
 goals, game design, **242–243**
 goggles, **32, 32**
 Central Processing level, 97
 cheat mode, 275
 Phobos Lab level, 90
 Unholy Cathedral level, 204
 Graphic Detail option, 19
 graphics, storing and extracting,
 286
 Gravis Ultrasound card problems,
 270
 Green, Shawn, 253
 grids, 33
 guided tour, **9–13**

H

Hall, Tom, 253
 Halls of the Damned level, 153
 list, 153
 maps, *154–155*
 secrets, **158–160**
 step by step, **156–158**
 strategy, **156**
 handguns, 11, 27
 against Former Humans, 22
 against Imps, 23
 Hangar level, 60
 list, 60
 maps, 61
 secrets, **64**
 step by step, **62–63**
 strategy, **62**
 health
 importance, 55–56

 medical aids, **34**
 potions, **36, 36**
 status bar, 10–11, *10, 37*
 supernatural artifacts, **36**
 Hell Keep level, 174
 list, 177
 maps, *175–176*
 secrets, **178–179**
 step by step, **177–178**
 strategy, **177**
 helmets, 11
 hidden-surface removal problem,
 244
 House of Pain level, 190
 list, 191–192
 maps, *191–192*
 secrets, **196–198**
 step by step, **193–195**
 strategy, **193**

I

IDBEHOLD cheat mode, 275
 IDCHOPPERS cheat mode, 275
 IDCLEV cheat mode, 275
 IDDDQD cheat mode, 274
 IDDDT cheat mode, 274–275
 ideal route maps, 50. *See also* blue-
 print and ideal route maps
 ideas, game, 252
 IDKFA cheat mode, 275
 IDMYPOS cheat mode, 275
 IDSPISPOPD cheat mode, 275
 implementation of Doom,
 243–245
 Imps, **23, 23**
 Command Control level, 84
 Nuclear Plant level, 69–70
 Toxin Refinery level, 77

Inferno episode

Dis level, **221–224**Hell Keep level, **174–179**House of Pain level, **190–198**Limbo level, **213–221**Mount Erebus level, **205–213**Pandemonium level, **185–190**secret level, 56, **224–230**

Slough of Despair level,

179–185

tips, 174

Unholy Cathedral level,

198–205Warrens level, **224–230**

infinite view distance, 242–244

initialization strings, 272

installation

controllers, **264–265**MultiPlayer mode, **266–267**,
267music cards, **263**, 263

saving settings, 265

Setup menu, **262–267**sound cards, **264**, 264installation maps. *See* blueprintand ideal route maps;
monsters, weapons, and
artifacts locator maps

interdimensional space travel, 4–5

interviews with Doom creators,
248–252invisibility, cheat mode, 275. *See*
also Blur artifactsInvulnerability artifacts, **36**, 36

cheat mode, 275

House of Pain level, 196

Mount Erebus level, 211, 213

Spawning Vats level, 164

Unholy Cathedral level, 203

Warrens level, 229

IPX protocol, 237–239, 266, 267

IPXSETUP program, **239–240**,
276

IRQs, 271–272

J

Johnson, Ray, 282

Joyce, Patrick, 282

joystick, configuring, 265, 266

K

keyboard

configuring, 265, 266

moving with, **7–8**

keys, 55, 55

MultiPlayer modes, 235

on status bar, 38

kills in performance, 56

Kirby, Bill, 286

Knee-Deep in the Dead episode

Central Processing level, **90–98**Command Control level,
79–85Computer Station level,
98–105Hangar level, **60–64**Military Base level, **112–118**Nuclear Plant level, **65–71**Phobos Anomaly level,
106–112Phobos Lab level, **85–90**secret level, 56, **112–118**Toxin Refinery level, **71–79**

L

latches, 55
Laumeister, Jason, 283
Lee, Carter, 283
Leukart, Hank, 238, 266, 272, 284
levels, episode
 bringing weapons through, 40
 cheat mode, 275
 command-line parameters for, 276
 development of, **253–256**
 in episodes, 55
 maps for, **50–53**
levels of difficulty, 9–10, **10**, **18–19**
licenses for MultiPlayer mode, 234
light amplification goggles, **32**, **32**
 Central Processing level, 97
 cheat mode, 275
 Phobos Lab level, 90
 Unholy Cathedral level, 204
lighting levels, 10
lightning balls, 25
Limbo level, 213–216
 list, 216
 maps, **214–215**
 secrets, **219–221**
 step by step, **217–219**
 strategy, **216**
line parameters, 239–240, **276**
 .LMP files, 283
Load Game option, 21
-loadgame parameter, 276
loading games in MultiPlayer modes, 237
Lost Souls, **24**, **24**

M

macro phrases, 236
magnifying maps, **33**
Main menus
 Doom, 9, 9, **17–18**, 17
 for installation, **262–267**, 263
maps, **32**, 32. *See also* blueprint and ideal route maps; monsters, weapons, and artifacts locator maps
cheat modes, 274–275
editor, 244–245
magnifying, **33**
MultiPlayer modes, 235
 using, 42
markers, digit, 33
medical aids, **34**
Medikits, **34**, **34**
 Central Processing level, 97–98
 Command Center level, 152
 Command Control level, 84–85
 Containment Area level, 133
 Deimos Anomaly level, 125
 Deimos Lab level, 141–142, 144
 Halls of the Damned level, 158–159
 House of Pain level, 198
 Military Base level, 116
 Nuclear Plant level, 70–71
 Pandemonium level, 189
 Phobos Anomaly level, 111
 Phobos Lab level, 89–90
 Slough of Despair level, 184–185
 Toxin Refinery level, 78–79
 Unholy Cathedral level, 204

- mega armor. *See* Combat Armor
 - vests
- MEMMAKER utility, 268
- memory problems, **268–269**
- messages
 - in MultiPlayer mode, 44, 234, 236
 - about objects, 19
- Messages option, 19
- Military Base level, 112
 - list, 112
 - maps, 113–114
 - secrets, **116–118**
 - step by step, **115–116**
 - strategy, **113–115**
- mind games in Deathmatch mode, **46**
- minus (–) key, 20, 33
- Modem Help File v3.0 add-on, 283
- modems, 43, 237–239, 239, 267
 - batch files, 284
 - contact list, 282
 - help file, 283
 - hints, 285
 - problems, **271–272**
- monsters. *See also* opponents
 - line parameters for, 276
 - maps. *See* monsters, weapons, and artifacts locator maps
 - respawning, 276
 - in teleporters, 121
- monsters, weapons, and artifacts
 - locator maps, 50
 - Central Processing level, 92
 - Command Center level, 147
 - Command Control level, 81
 - Computer Station level, 100
 - Containment Area level, 129
 - Deimos Anomaly level, 123
 - Deimos Lab level, 139
 - Dis level, 222
 - Fortress of Mystery level, 171
 - Halls of the Damned level, 155
 - Hangar level, 61
 - Hell Keep level, 176
 - House of Pain level, 192
 - interpreting, **53–54**
 - Limbo level, 215
 - Military Base level, 114
 - Mount Erebus level, 207
 - Nuclear Plant level, 66
 - Pandemonium level, 187
 - Phobos Anomaly level, 108
 - Phobos Lab level, 87
 - Refinery level, 135
 - Slough of Despair level, 181
 - Spawning Vats level, 162
 - Tower of Babel level, 168
 - Toxin Refinery level, 73
 - Unholy Cathedral level, 200
 - Warrens level, 226
- Mount Erebus level, 205
 - list, 205–206
 - maps, 206–207
 - secrets, **211–213**
 - step by step, **208–210**
 - strategy, **207–208**
- mouse
 - control problems, **271**
 - default settings, 8, 265, 266
 - moving with, **7–8**
 - sensitivity, 20
- Mouse Sensitivity option, 20
- movements, controlling, **6–7**
 - with keyboard, **7**
 - mastering, **39–40**
 - with mouse and keyboard, **7–8**

180-degree turns, **8**
problems, **271**
mug on status bar, **38**
MultiPlayer mode, **234**
controls, **236–237**
cooperative mode, **43–44**,
234–236
Deathmatch mode, **44–46**,
234–236
installation, **266–267**, **267**
launching, **238–240**
options, **237**
platforms, **237–238**
problems, **271–272**
strategies, **42–46**
music cards, **263**, **263**

N

names, saved games, **20**
Neisius, Bill, **284**, **286**
networks, **43**, **237–239**, **239**, **267**
batch files for, **284**
in game design, **245**
New Game option, **9**, **18**
NEWDEU v4.1 add-on, **286**
-nodes parameter, **240**
-nomonsters parameter, **276**
Novell Netware, **237–238**
Nuclear Plant level, **65**
list, **65–66**
maps, **65–66**
secrets, **70–71**
step by step, **67–70**
strategy, **66–67**

O

“Official Doom FAQ,” **238**, **266**,
272
180-degree turns, **8**
opening
gates, **12**
secret doors, **13**
opponents
Barons of Hell, **25–26**, **25**
Cacodemons, **25**, **25**
Cyberdemons, **26**, **26**
Demons, **23–24**, **24**
Former Human Sergeants,
23, **23**
Former Humans, **22**, **22**
Imps, **23**, **23**
Lost Souls, **24**, **24**
Specters, **24**, **24**
Spider Mastermind, **27**
Options menu, **19–20**, **19**
Osborne, Bobby, **282**
“Out of Memory” messages,
268–269

P

Pandemonium level, **185**
list, **185**
maps, **186–187**
secrets, **189–190**
step by step, **188–189**
strategy, **186–187**
Pantuso, Joe, **281**
PAR performance, **57**
parameters, line, **239–240**, **276**
patches, problems with, **269**

pausing
 in MultiPlayer modes, 237
 when viewing map, 42

performance, **56–57**, 236

perspective, 10, 10

Petersen, Sandy
 interview, **248–252**
 on levels, **253–256**

Phobos Anomaly level, 106
 list, 106
 maps, 107–108
 secrets, **111–112**
 step by step, **109–111**
 strategy, **106, 109**

Phobos Lab level, 85
 list, 85
 maps, 86–87
 secrets, **89–90**
 step by step, **87–89**
 strategy, **86–87**

picking up objects, 11–12

plans in cooperative mode, **44**

plasma rifles, **30, 30**
 against Barons of Hell, 25
 against Cacodemons, 25
 Command Center level,
 149–151
 against Cyberdemons, 26
 against Spider Mastermind, 27

platforms, 12, **52**. *See also* secrets

playback add-on, 283

-playdemo parameter, 277

plus (+) key, 20, 33

ports for music cards, 263, 263

position in cheat mode, 275

power-ups, **36**
 cheat mode, 275
 maps. *See* monsters, weapons,
 and artifacts locator maps

prerecorded messages, 236

programming of Doom, **243–245**

protective items, **34–35**

Punchatz, Gregor, 257–258

PWADs, creating, 283

Q

Quake game, **251–252**

Quick Save option, 21

Quinet, Raphael, 283, 286

Quit Game option, 22

R

radiation suits, **35, 35**
 Central Processing level, 93,
 97–98
 cheat mode, 275
 Command Center level, 152
 Command Control level, 84
 Computer Station level, 105
 Deimos Lab level, 142–143
 Limbo level, 220
 Mount Erebus level, 212
 Phobos Lab level, 89
 Refinery level, 137
 Warrens level, 229

RanDOOM v1.41 add-on, 282

Read This option, 21

-record parameter, 277

Refinery level, 133–134
 list, 135
 maps, 134–135
 secrets, **136–137**
 strategy, **135–136**

rendering engine, 243–244

-respawn parameter, 276

respawning monsters, 234, 276

resuming MultiPlayer-mode games, **266–267**

RGDAUX.ZIP file, 281

rockets and rocket launchers, **29**,
29, **31**, **31**

against Barons of Hell, 25

against Cacodemons, 25

against Cyberdemons, 26

Military Base level, 115

against Spider Mastermind, 27

Romero, John

on cheat modes, **274–275**

interview, **248–252**

level design by, 253–254

Run Network/Modem/Serial

Game option, 238, 266

runDOOM v1.2 add-on, 283

running, 11

S

Saraniero, David, 283

Save Game option, **20–21**

Save Settings & Run Doom option,
265

saved games, resuming, **266–267**

saving games

in MultiPlayer modes, 237

option, **20–21**

scoring, **56–57**, 236

screen shots, 277

Screen Size option, 20

secret doors, **12–13**, **52**. *See also*
secrets

secret levels, **56**

Inferno episode, 210, **224–230**

Knee-Deep in the Dead

episode, 74, **112–118**

Shores of Hell episode, 145,
170–172

secrets

Central Processing level, **96–98**

Command Center level,

151–153

Command Control level,

84–85

Computer Station level,

104–105

Containment Area level,

131–133

Deimos Anomaly level,

125–126

Deimos Lab level, **141–145**

Halls of the Damned level,

158–160

Hangar level, **64**

Hell Keep level, **178–179**

House of Pain level, **196–198**

Limbo level, **219–221**

Military Base level, **116–118**

Mount Erebus level, **211–213**

Nuclear Plant level, **70–71**

Pandemonium level, **189–190**

in performance, 56

Phobos Anomaly level,

111–112

Phobos Lab level, **89–90**

Refinery level, **136–137**

Slough of Despair level,

183–185

Spawning Vats level, **164–166**

Toxin Refinery level, **78–79**

uncovering, **41–42**

- Unholy Cathedral level, **203–205**
- Warrens level, **228–230**
- Security Armor vests, 12, **34–35**, 34
 - Central Processing level, 97–98
 - Command Center level, 151
 - Command Control level, 82–83
 - Containment Area level, 131–133
 - Deimos Anomaly level, 125
 - Deimos Lab level, 141–142
 - Halls of the Damned level, 159
 - Hangar level, **62–63**
 - House of Pain level, 197
 - Military Base level, 117
 - Mount Erebus level, 211
 - Nuclear Plant level, 70
 - Pandemonium level, 190
 - status bar, 38
 - Toxin Refinery level, 78
 - Warrens level, 229
- security cards, 55, 55
 - Central Processing level, 93–94, 97
 - Command Control level, 85
 - Computer Station level, 99, 101, 104–105
 - Containment Area level, 131–132
 - Deimos Anomaly level, 125–126
 - Deimos Lab level, 143
 - Military Base level, 116–117
 - Nuclear Plant level, 68
 - Phobos Lab level, 89–90
 - Refinery level, 136
 - Spawning Vats level, 165–166
 - Toxin Refinery level, 79
- Select Controller Type option, 265
- Select Music Card option, 263, 263
- Select Sound FX Card option, 264, 264
- SERSETUP program, **238–240**, 276
- Setup menu
 - for installation, **262–267**, 263
 - for MultiPlayer mode, **238–239**, 238
- SFX player add-on, 284
- shareware market, 252
- shells, **31**, 31
- Shift key, 7, 11
- Shores of Hell, episode 2
 - Command Center level, **145–153**
 - Containment Area level, **126–133**
 - Deimos Anomaly level, **121–126**
 - Deimos Lab level, **137–145**
 - Fortress of Mystery level, **170–172**
 - Halls of the Damned level, **153–160**
 - Refinery level, **133–137**
 - secret level, 56, **170–172**
 - Spawning Vats level, **160–166**
 - tips, **120–121**
 - Tower of Babel level, **166–169**
- shotguns, **28**, 28
 - against Former Humans Sergeants, 23
 - importance, 40
 - against Imps, 23

- against Lost Souls, 24
- against Specters, 24
- sidestepping, **11**
 - mouse button for, 8, 265
 - practicing, 40
- Sikes, Wayne, 281
- size
 - maps, 33
 - screen, 20
- skill parameter, 276
- skull cursor, 9, 17
- slime barrels, 11, **41**
- Slough of Despair level, 179
 - list, 179
 - maps, 180–181
 - secrets, **183–185**
 - step by step, **182–183**
 - strategy, **182**
- Smart, Gregory, 282
- SMARTDRV.EXE program,
 - 269–270
- Soul Spheres, **36**, 36
 - Central Processing level, 95–98
 - Command Control level, 83
 - Computer Station level, 105
 - Containment Area level, 132
 - Deimos Lab level, 142,
 - 144–145
 - Halls of the Damned level, 159
 - House of Pain level, 197
 - Limbo level, 219
 - Mount Erebus level, 213
 - Nuclear Plant level, 68–69
 - Phobos Anomaly level, 111
 - Phobos Lab level, 89
 - Refinery level, 137
 - Slough of Despair level, 184
 - Spawning Vats level, 165
 - Toxin Refinery level, 78–79
 - Unholy Cathedral level, 204
- sound
 - editors, 284–285
 - files, 285–286
 - playing, 285
 - problems, **270**
 - volume, 20
- Sound Blaster card problems, 270
- sound cards, installing, **264**, 264
- Sound Volume option, 20
- spacebar, 7, 17
- spawning in MultiPlayer mode,
 - 234, 276
- Spawning Vats level, 160
 - list, 160
 - maps, 161–162
 - secrets, **164–166**
 - step by step, **161–164**
 - strategy, **160–161**
- specifications, 284
- Specters, **24**, 24, 109–110
- speed as game design goal, 242,
 - 244
- Spider Mastermind, **27**
- Spiritual Armor, 11, **36**, 36
 - Command Center level, 153
 - Command Control level, 84
 - Deimos Anomaly level, 126
 - Deimos Lab level, 142, 144
 - Hangar level, 64
 - Nuclear Plant level, 70
 - status bar, 38
- Spy feature, 235, **237**
- stairs, walking up, 11
- startup parameters, 239–240, **276**

- Status Bar, 10–11, *10*, **37–38**, 38
 - for ammo, 30
 - for health, 34
 - in MultiPlayer modes, 235
 - Stimpacks, **34**, 34
 - Central Processing level, 97
 - Command Center level, 151
 - strafing, 7, 11, 40
 - strategies, **39**
 - Central Processing level, **93**
 - Command Center level, **147–148**
 - Command Control level, **81–82**
 - Computer Station level, **101**
 - Containment Area level, **127**
 - Deimos Anomaly level, **123**
 - Deimos Lab level, **138–140**
 - Dis level, **222–224**
 - exploring, **41–42**
 - fighting, **40–41**
 - Halls of the Damned level, **156**
 - Hangar level, **62**
 - Hell Keep level, **177**
 - House of Pain level, **193**
 - Limbo level, **216**
 - Military Base level, **113–115**
 - Mount Erebus level, **207–208**
 - moving, **39–40**
 - MultiPlayer mode, **42–46**
 - Nuclear Plant level, **66–67**
 - Pandemonium level, **186–187**
 - Phobos Anomaly level, **106**, **109**
 - Phobos Lab level, **86–87**
 - Refinery level, **135–136**
 - Slough of Despair level, **182**
 - Spawning Vats level, **160–161**
 - Toxin Refinery level, **73–74**
 - Unholy Cathedral level, **201–202**
 - Warrens level, **227–228**
 - Sun-Tzu
 - on enemies, 22
 - on strategies, 39
 - supernatural artifacts, **36**
 - cheat mode, 275
 - maps. *See* monsters, weapons, and artifacts locator maps
 - support, 268
 - switches, **12–13**, *13*. *See also* blue-print and ideal route maps; secrets
 - on maps, **52**
 - strategies, 42
 - SYBEX forum, 272, **280–285**
 - system crashes, 269
- T**
- tallies, **56–57**, 236
 - Taylor, Dave, 274
 - technical support, 268
 - teleporters
 - Command Center level, 152
 - Deimos Anomaly level, 125–126
 - Deimos Lab level, 141, 143–145
 - Hell Keep level, 179
 - House of Pain level, 196
 - Limbo level, **218–221**
 - on maps, **53**
 - Military Base level, 115–116
 - Mount Erebus level, 211–213
 - Phobos Anomaly level, 111
 - Phobos Lab level, 90
 - Shores of Hell episodes, 121

Slough of Despair level, 184–185

Spawning Vats level, 165

Unholy Cathedral level, **201–204**

Warrens level, 228–229

terminate-and-stay-resident (TSR) programs, 268

texture mapping, 244

total ammo on status bar, 38

tour, **9–13**

Tower of Babel level, 166
maps, 167–168
step by step, **166, 169**

Toxin Refinery level, 71–72
list, 72–73
maps, 72–73
secrets, **78–79**
step by step, **74–78**
strategy, **73–74**

triggers, 12–13, **52**. *See also* blueprint and ideal route maps; secrets

troubleshooting tips
control problems, **271**
general operation, **268–270**
MultiPlayer problems, **271–272**
sound problems, **270**

TSR (terminate-and-stay-resident) programs, 268

Turbyfill, Keith, 283

turns, **8, 11**

U

UAC (Union Aerospace Corporation), 4

Unholy Cathedral level, 198–201

list, 201

maps, 199–200

secrets, **203–205**

step by step, **202–203**

strategy, **201–202**

Union Aerospace Corporation (UAC), 4

“Unofficial Specs File,” 284

Utilities, 286

V

vests. *See* Combat Armor vests; Security Armor vests

view distance, 242–244

volume option, 20

W

.WAD files, editing, 283

walking, 11
abreast, in cooperative mode, 44
through walls, 275

wallpaper, 284

walls
as shields, **41**
walking through, 275

-warp parameter, 277

Warrens level, 224–227
list, 227
maps, 225–226
secrets, **228–230**
step by step, **228**
strategy, **227–228**

weapons, **28**
BFG 9000, **30, 30**
chainguns, **29, 29**
chainsaws, **29, 29**
cheat mode, 275

- Deathmatch mode, **45**
- through levels, 40
- maps. *See* monsters, weapons,
and artifacts locator maps
- MultiPlayer modes, 235
- picking up, 12
- plasma rifles, **30, 30**
- rocket launchers, **29, 29**
- shotguns, **28, 28**
- status bar, 37
- Wilkinson, Eric, 285
- Williams, Cris, 285
- world geography, 242, 244
- Wyber, Brendon, 283



Other Player
(MultiPlayer Mode)



Baron of Hell



Former Human



Former Human
Sergeant



Lost Soul

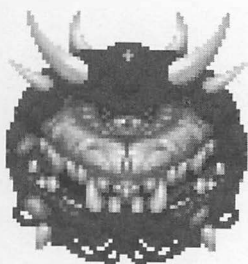

Cacodemon



Imp



Demon



Cyberdemon

Key to the Maps

Code Weapon

BFG BFG 9000

CG Chaingun

CS Chainsaw

PG, PR Plasma Gun

RL Rocket Launcher

SG Shotgun

Code Building Feature

d Door

p Platform

s Switch

t Trigger

T Teleporter

Code Power-up

BP Backpack

BS Berserk Pack

CA Combat Armor

CM Computer Level Map

IN Invisibility Blur

IV Invulnerability Blur

LG Light Amplification Goggles

RS Radiation Suit

SA Security Armor

SS Soul Sphere

bc, bs Blue Card, Blue Skull Key

rc, rs Red Card, Red Skull Key

yc, ys Yellow Card, Yellow Skull Key

THE OFFICIAL

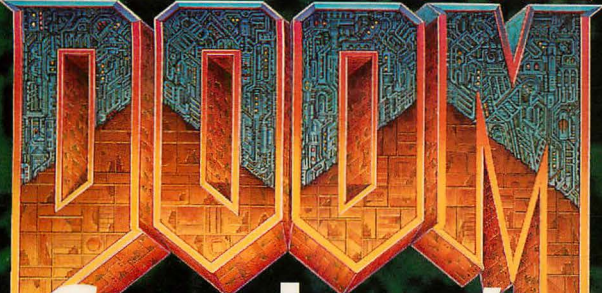

Survivor's Strategies & Secrets

Exclusively Endorsed by id Software,
the Creators of the Game

Helps You Grow from a Doom
Babe in Arms to the Baddest
Bandito in the Game

Guides You through Every
Gut-Churning Episode and
Level of Doom

Get Ready to Kick Some Interdimensional Butt!

The Official Doom Survivor's Strategies & Secrets is the Doom-monger's guide to survival in a hostile universe. With an exclusive endorsement by id Software, the creators of Doom, this handbook is your only source for:

- **Basic training.** Find out who you are, where you are, and what you're supposed to be doing — *before* you get blown away.
- **Complete coverage of all Doom episodes and levels.** Learn what to expect at every level of Knee-Deep in the Dead, The Shores of Hell, and Inferno.
- **Special intelligence.** Includes previously unreleased information and a glimpse of the macabre minds who brought you Doom.

This is war. You'll find scores of cheat codes, insider tips, and winning strategies, plus a complete guide to Doom add-ons, utilities, and resources.

You can't do it alone. Learn the secrets of teleportation; how to annihilate the Barons of Hell; how to conquer Spider Mastermind and Cyberdemon with the aid of enemy monsters; and dozens of other solutions to Doom's most challenging scenarios.

About the Author

Jonathan Mendoza is a writer, designer, and consultant for the Texas Association of School Boards. He spent many years at Tandy Corporation, where he wrote scores of game and hardware manuals. A lifelong game player and an avid student of human nature, he has also brought his insights to ad campaigns and scripts for radio and television.



ISBN 0-7821-1578-0